



## Standard Test Methods for Performance of Steam Cookers<sup>1</sup>

This standard is issued under the fixed designation F 1484; the number immediately following the designation indicates the year of original adoption or, in the case of revision, the year of last revision. A number in parentheses indicates the year of last approval. A superscript epsilon ( $\epsilon$ ) indicates an editorial change since the last revision or reapproval.

### 1. Scope

1.1 This test method evaluates the energy consumption and cooking performance of steam cookers. The food service operator can use this evaluation to select a steam cooker and understand its energy consumption.

1.2 This test method is applicable to the following steam cookers: high-pressure, low-pressure, and pressureless steam cookers (Specification F 1217 Grades A, B, and C); convection and non-convection steam cookers; steam cookers with self-contained gas-fired, electric, or steam coil steam generators, and those connected directly to an external potable steam source (Specification F 1217 Styles i, ii, iii, and iv). The steam cookers will be tested for the following (where applicable):

- 1.2.1 Maximum energy input rate (see 10.2).
- 1.2.2 Preheat energy consumption and duration (see 10.3).
- 1.2.3 Idle energy rate (see 10.4).
- 1.2.4 Pilot energy rate (see 10.5).
- 1.2.5 Frozen green pea load cooking energy efficiency (see 10.7).
- 1.2.6 Frozen green pea load production capacity (see 10.7).
- 1.2.7 Whole potato load cooking energy efficiency (see 10.9).
- 1.2.8 Whole potato load production capacity (see 10.9).
- 1.2.9 Water consumption (see 10.7 and 10.9).
- 1.2.10 Condensate temperature (see 10.7 and 10.9).
- 1.2.11 Cooking uniformity (see 10.10).

1.3 The values stated in inch-pound units are to be regarded as standard. The SI units given in parentheses are for information only.

1.4 *This standard may involve hazardous materials, operations, and equipment. It does not address all of the safety concerns, if any, associated with its use. It is the responsibility of the user of this standard to establish appropriate safety and health practices and determine the applicability of regulatory limitations prior to use.*

<sup>1</sup> This test method is under the jurisdiction of ASTM Committee F26 on Food Service Equipment and is the direct responsibility of Subcommittee F26.06 on Productivity and Energy Protocol.

Current edition approved April 1, 2004. Published April 2004. Originally approved in 1993. Last previous edition approved in 1999 as F 1484 – 99.

### 2. Referenced Documents

#### 2.1 ASTM Standards:<sup>2</sup>

A 36/A 36M Specification for Structural Steel  
D 3588 Practice for Calculating Heat Value, Compressibility Factor, and Relative Density (Specific Gravity) of Gaseous Fuels

F 1217 Specification for Cooker, Steam

#### 2.2 ASHRAE Documents:<sup>3</sup>

ASHRAE Handbook of Fundamentals, “Thermal and Related Properties of Food and Food Materials,” Chapter 30, Table 1, 1989.

ASHRAE Handbook of Fundamentals, “Thermodynamic Properties of Water at Saturation,” Chapter 6, Table 2, 1989.

#### 2.3 Other Document:<sup>4</sup>

Development and Application of a Uniform Testing Procedure for Steam Cookers

### 3. Terminology

#### 3.1 Definitions:

3.1.1 *boiler, n*—self-contained vessel, separate from the cooking cavity, wherein water is boiled to produce steam for the steam cooker. Also called a steam generator.

3.1.2 *condensate, n*—a mixture of condensed steam and cooling water, exiting the steam cooker and directed to the floor drain.

3.1.3 *cooking energy efficiency, n*—quantity of energy imparted to the specified food product expressed as a percentage of energy consumed by the steam cooker during the cooking event.

3.1.4 *cooking energy rate, n*—average rate of energy consumption (kBtu/h or kW) during the cooking energy efficiency test. Refers to any loading scenario in the green pea or potato load tests.

<sup>2</sup> For referenced ASTM standards, visit the ASTM website, www.astm.org, or contact ASTM Customer Service at service@astm.org. For *Annual Book of ASTM Standards* volume information, refer to the standard’s Document Summary page on the ASTM website.

<sup>3</sup> Available from American Society of Heating, Refrigerating and Air Conditioning Engineers, Inc., 1791 Tullie Circle, NE, Atlanta, GA 30329.

<sup>4</sup> Available from the Food Service Technology Center, 12949 Alcosta Blvd., #101, San Ramon, CA 94583.

3.1.5 *electric energy rate, n*—refers to rate of electric energy consumption (kW) by steam cookers whose primary fuel source is not electricity (for example, gas). Electric energy is measured and reported separately from the primary fuel energy so that the respective fuel prices can be applied to estimate energy costs.

3.1.6 *green pea load, n*—12 by 20 by 2½ in. (300 by 500 by 65 mm) perforated hotel pan filled with 8.0 ± 0.2 lb (3.6 ± 0.1kg) of fresh-frozen, grade A, green peas.

3.1.7 *high-pressure steam cooker, n*—steam cooker wherein cooking compartment operates between 10 and 15 psig (Specification F 1217 Classification Grade C).

3.1.8 *idle energy rate, n*—rate of energy consumed by the steam cooker while maintaining the boiler or reservoir at a manufacturer-defined operating pressure or temperature with no cooking taking place.

3.1.9 *low-pressure steam cooker, n*—steam cooker wherein cooking compartment operates between 3 and 9.9 psig (Specification F 1217 Classification Grade B).

3.1.10 *maximum energy input rate, n*—peak rate at which an appliance consumes energy, typically reflected during preheat.

3.1.11 *pilot energy rate, n*—rate of energy consumption (kBtu/h) by a gas steam cooker’s standing pilot (if applicable).

3.1.12 *potato load, n*—one 12 by 20 by 2½ in. (300 by 500 by 65 mm) perforated hotel pan filled with 50 ± 2 fresh, whole, US No. 1, size B, red potatoes, weighing 8.0 ± 0.2 lb (3.6 ± 0.1 kg).

3.1.13 *preheat, n*—process of bringing the steamer (boiler) water from city supply temperature to operating temperature (pressure).

3.1.14 *preheat duration, n*—total time required for preheat, from preheat initiation at controls to when the steam cooker is ready to cook.

3.1.15 *preheat energy, n*—amount of energy consumed by the steam cooker during a preheat.

3.1.16 *pressureless steam cooker, n*—steam cooker wherein cooking compartment operates between 0 and 2.9 psig (Specification F 1217 Classification Grade A).

3.1.17 *production capacity, n*—maximum rate (lb (kg)/h) at which steam cooker can bring the specified food product to a specified “cooked” condition.

3.1.18 *production rate, n*—rate (lb (kg)/h) at which steam cooker brings the specified food product to a specified “cooked” condition. Does not necessarily refer to maximum rate. The production rate varies with the loading scenario and the amount of product being cooked.

3.1.19 *steam cooker, n*—cooking appliance wherein heat is imparted to food in a closed compartment by direct contact with steam. The compartment can be at or above atmospheric pressure. The steam can be static or circulated.

3.1.20 *water consumption, n*—water consumed by the steam cooker. Includes both water used in the production of steam and cooling water (if applicable) for condensing/cooling unused steam.

#### 4. Summary of Test Method

4.1 The maximum energy input rate is determined to check whether the steam cooker is operating properly. If the measured input rate is not within 5 % of the rated input, all further

testing ceases and the manufacturer is contacted. The manufacturer may make appropriate changes or adjustments to the steam cooker.

4.2 The energy and time required to preheat the steamer to an operating condition are determined.

4.3 Idle energy rate is determined for the steamer while it is maintaining operating pressure or temperature when no cooking is taking place.

4.4 Pilot energy rate is determined when applicable to a gas fired steam cooker under test.

4.5 Green pea load cooking energy efficiency is determined by cooking a capacity number of frozen green pea loads from 0 to 180°F (–18 to 82°C).

4.6 Whole potato load cooking energy efficiency is determined by cooking a capacity number of fresh whole potatoes to a specified doneness.

4.7 Green pea load and whole potato load production capacities (lb<sub>pea</sub>/h or lb<sub>potato</sub>/h (kg<sub>pea</sub>/h or kg<sub>potato</sub>/h)) are determined by the respective cooking energy efficiency tests.

4.8 Water consumption (gal/h (L/h)) is monitored during both cooking energy efficiency tests to determine the rate of water usage.

4.9 Condensate temperature is monitored during both cooking energy efficiency tests.

4.10 The uniformity of heating within the steamer’s compartment is determined and reported based on the average temperature on each pan during ice load cooking tests (pans of ice simulating pans of frozen food).

#### 5. Significance and Use

5.1 The maximum energy input rate test is used to confirm that the steam cooker is operating at the manufacturer’s rated input. This test would also indicate any problems with the electric power supply, gas service pressure, or steam supply flow or pressure.

5.2 Preheat energy and duration can be useful to food service operators for managing power demands and knowing how quickly the steam cooker can be ready for operation.

5.3 Idle energy rate and pilot energy rate can be used to estimate energy consumption.

5.4 Green pea load cooking energy efficiency is an indicator of steam cooker energy performance when cooking frozen products under various loading conditions. This allows the food service operator to consider energy costs when selecting a steam cooker.

5.5 Potato load cooking energy efficiency is an indicator of steam cooker energy performance when cooking foods that require long cook times (for example, potatoes, beans, rice, lasagna or casserole rethermalization). The test demonstrates the difference in energy efficiency between pressure and pressureless steam cookers for this type of cooking event. The information may help a food service operator to evaluate what type of steamer to select (pressure versus pressureless versus dual pressure mode) from an energy performance perspective.

5.6 Green pea load production capacity and potato load production capacity can be used by food service operators to choose a steam cooker to match their particular food output requirements.

5.7 Water consumption characterization is useful for estimating water and sewerage costs associated with appliance operation.

5.8 Condensate temperature measurement is useful to verify that the temperature does not exceed regional building code limits.

5.9 Cooking uniformity provides information regarding the steamer's ability to cook food at the same rate throughout the steamer's compartment.

## 6. Apparatus

6.1 *Watt-Hour Meter*, for measuring the electrical energy consumption of a steam cooker, shall have a resolution of at least 10 Wh and a maximum uncertainty no greater than 1.5 % of the measured value for any demand greater than 100 W. For any demand less than 100 W, the meter shall have a resolution of at least 10 Wh and a maximum uncertainty no greater than 10 %.

6.2 *Gas Meter*, for measuring the gas consumption of a steam cooker, shall be a positive displacement type with a resolution of at least 0.01 ft<sup>3</sup> (0.0003 m<sup>3</sup>) and a maximum uncertainty no greater than 1 % of the measured value for any demand greater than 2.2 ft<sup>3</sup>/h (0.06 m<sup>3</sup>/h). If the meter is used for measuring the gas consumed by the pilot lights, it shall have a resolution of at least 0.01 ft<sup>3</sup> (0.0003 m<sup>3</sup>) and have a maximum uncertainty no greater than 2 % of the measured value.

6.3 *Steam Flow Meter*, for measuring the flow of steam to a steam cooker that uses either a direct external potable steam source or a steam coil steam generator. Shall have a resolution of 0.01 ft<sup>3</sup> (0.0003 m<sup>3</sup>) and a maximum uncertainty of 1 % of the measured value.

6.4 *Pressure Gage*, for measuring pressure of steam to a steam cooker that uses either a direct external potable steam source or a steam coil steam generator. Shall have a resolution of 0.5 psig (3.4 kPa) and a maximum uncertainty of 1 % of the measured value.

6.5 *Canopy Exhaust Hood*, 4 ft (1.2 m) in depth, wall-mounted with the lower edge of the hood 6 ft, 6 in. (2.0 m) from the floor and with the capacity to operate at a nominal exhaust ventilation rate of 150 cfm per linear foot (230 L/s per linear meter) of active hood length. This hood shall extend a minimum of 6 in. (150 mm) past both sides and the front of the cooking appliance and shall not incorporate side curtains or partitions. Makeup air shall be delivered through face registers or from the space, or both.

6.6 *Pressure Gage*, for monitoring boiler pressure. The gage shall have a resolution of 0.5 psig (3.4 kPa) and a maximum uncertainty of 1 % of the measured value.

6.7 *Pressure Gage*, for monitoring natural gas pressure. The gage shall have a range of 0 to 15 in. H<sub>2</sub>O (0 to 3.7 kPa), a resolution of 0.5 in. H<sub>2</sub>O (125 Pa), and a maximum uncertainty of 1 % of the measured value.

6.8 *Temperature Sensor*, for measuring gas temperature in the range of 50 to 100°F (10 to 40 °C), with a resolution of 0.1°F (0.05 °C) and an uncertainty of ±0.5°F (0.3°C).

6.9 *Barometer*, for measuring absolute atmospheric pressure, to be used for adjustment of measured natural gas volume

to standard conditions, having a resolution of 0.2 in. Hg (670 Pa) and an uncertainty of 0.2 in. Hg (670 Pa).

6.10 *Flow Meter*, for measuring total water consumption of the appliance. The meter shall have a resolution of 0.01 gal (40 ml), and an uncertainty of 0.01 gal (40 ml), at flow rate as low as 0.2 gpm (13 ml/s).

6.11 *Stopwatch*, with a 1-s resolution.

6.12 *Analytical Balance Scale*, for measuring weight of food for cooking test loads and for weighing hotel pans. It shall have a resolution of 0.01 lb (5 g) and an uncertainty of 0.01 lb (5 g).

6.13 *Calibrated Exposed Junction Thermocouple Probes*, with a range from -20 to 400°F (-30 to 200°C), with a resolution of 0.2°F (0.1°C) and an uncertainty of 0.5°F (0.3 °C), for measuring temperature of frozen green peas, potatoes, calorimeter water, water entering the boiler, and condensate. Calibrated Type T thermocouples (24 GA wire) are a good choice.

6.14 *Hotel Pans*, for frozen green pea and potato loads, perforated 12 by 20 by 2½ in. (300 by 500 by 65 mm) stainless steel weighing 2.8 ± 0.2 lb (1.3 ± 0.1 kg).

6.15 *Water-Bath Calorimeter*, for temperature determination of the cooked green pea load. The calorimeter is comprised of five components and are shown in Fig. 1: inner container—cylindrical, 0.087-in. (2.2-mm) thick walled, plastic drum (PG&E found that a 15-gal container is adequate for most applications); drum insulation—R-25 fiberglass insulation; drum lid—plastic lid double reinforced with 2-in. (50 mm) thick polystyrene board; stirrer—3-ft long, ¼-in. diameter, steel rod with propeller welded to one end; thermocouple tree—¼-in. diameter pipe with five temperature sensors attached laterally equidistant from one another. The sensors must be adjusted so that they are fully submerged for each loading scenario. A convenient way to construct the water-bath calorimeter is to place the inner container on a 2-in. (50 mm) thick polystyrene board. Wrap the outside of the drum with 1 ft thick R-25 fiberglass insulation so no drum wall is exposed. Cover the fiberglass insulation with plastic liner to waterproof the interior. Construct the thermocouple tree by affixing five type T thermocouple probes 3 in. apart along the copper pipe. Fix the thermocouple tree vertically along the drum wall as to avoid contact with the stirrer. Drill a ½-in. hole in the center of the plastic/polystyrene lid. Place the propeller end of the stirrer in the drum and close the lid, allowing the opposite end of the stirrer to pass through the center of the lid. The calorimeter can be placed on castors for ease in mobility, and the content can be stirred manually or with the aid of a portable, handheld drill during a test.

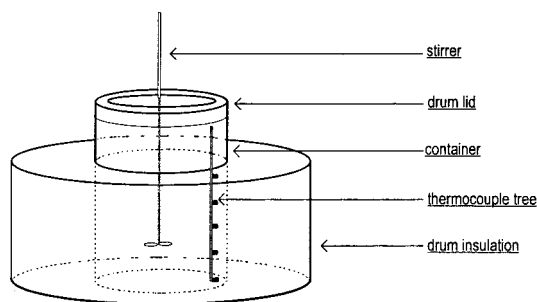

FIG. 1 Water-Bath Calorimeter

6.16 *Hypodermic-Style Thermocouple Probe* for measuring potato temperatures. Minimum diameter makes for easier insertion and faster response. Resolution and uncertainty shall be the same as in 6.13.

6.17 *Surface Temperature Thermocouple Probe*, for measuring boiler surface temperature. Resolution and uncertainty shall be the same as in 6.13. This sensor will not be needed if the city water supply temperature is  $70 \pm 5^\circ\text{F}$  ( $21 \pm 3^\circ\text{C}$ ).

6.18 *Platform Balance Scale*, or appropriate load cells, used to measure the weight of the water-bath calorimeter and content during the frozen green pea load test. Shall have the capacity to accommodate the total weight of calorimeter plus the cooked food product and water. The resolution shall be 0.2 lb (10 g) with an uncertainty of 0.2 lb (10 g).

6.19 *Hotel Pans*, for ice loads, solid 12 by 20 by 2½-in. (300 by 500 by 65-mm) stainless steel, weighing  $2.8 \pm 0.2$  lb ( $1.3 \pm 0.1$  kg), with a temperature sensor located in the center of each pan 5/8 in. (16 mm) from the bottom. A convenient method is to have Type T thermocouple probes with a stainless-steel protective sheath fabricated in the shape shown in Fig. 2. The sensing point is exposed and isolated thermally from the stainless-steel sheath. The probe is strapped to the pan using steel shim stock welded to the pan using a strain gage welder. The thermocouple lead TFE-fluorocarbon sheath is minimum thickness (TFE-fluorocarbon wrap rather than extruded TFE-fluorocarbon) to minimize the escape of steam through the door gasket where the thermocouple exits the cooking compartment. The lead is long enough to allow connection to the monitoring device while the ice loads are in the freezer, while they are being weighed, and while they are in the steam cooker.

## 7. Reagents and Materials

7.1 Quality of water used to fill the boiler shall meet the manufacturer's specifications.

7.2 Green peas shall be fresh-frozen, grade A, stabilized at  $0 \pm 5^\circ\text{F}$  ( $-18 \pm 2^\circ\text{C}$ ).

7.3 Potatoes shall be fresh, whole, US No. 1, Size B, red potatoes. The average weight of the potatoes shall be  $0.16 \pm 0.02$  lb ( $73 \pm 9$  g).

NOTE 1—Red potatoes are sold in three sizes: A, B, and C. This test uses Size B.

7.4 Water used for the cooking uniformity test shall have a maximum hardness of three grains per gallon. Distilled water may be used.

## 8. Sampling

8.1 *Steam Cooker*— A representative production model shall be selected for performance testing.

## 9. Preparation of Apparatus

9.1 Install the appliance in accordance with the manufacturer's instructions under a 4 ft (1.2 m) deep canopy exhaust hood mounted against the wall, with the lower edge of the hood 6 ft, 6 in. (2.0 m) from the floor. Position the steam cooker so that the front edge is 6 in. (150 mm) inside the front edge of the hood. In addition, both sides of the steam cooker shall be a minimum of 3 ft (1.1 m) from any wall, side partition, or other operating appliance. Equipment configuration is shown in Fig. 3. The exhaust ventilation rate shall be 150 cfm per linear foot (230 L/s per linear meter) of hood length. The associated heating or cooling system shall be capable of maintaining an ambient temperature of  $75 \pm 5^\circ\text{F}$  ( $24 \pm 3^\circ\text{C}$ ) within the testing environment when the exhaust ventilation system is working without the appliance being operated.

9.2 Connect the steam cooker to a calibrated energy test meter. For gas installations, a pressure regulator shall be installed downstream from the meter to maintain a constant pressure of gas for all tests. Both the pressure and temperature of the gas supplied to a steam cooker, as well as the barometric pressure, shall be recorded during each test so that the measured gas flow can be corrected to standard conditions. For a steam cooker that uses either a direct external potable steam

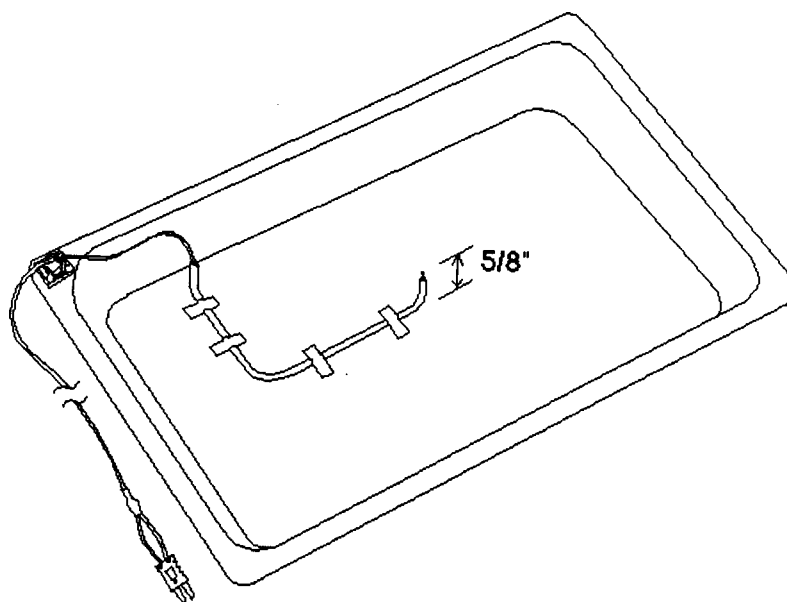

FIG. 2 Hotel Pan with Thermocouple Probe

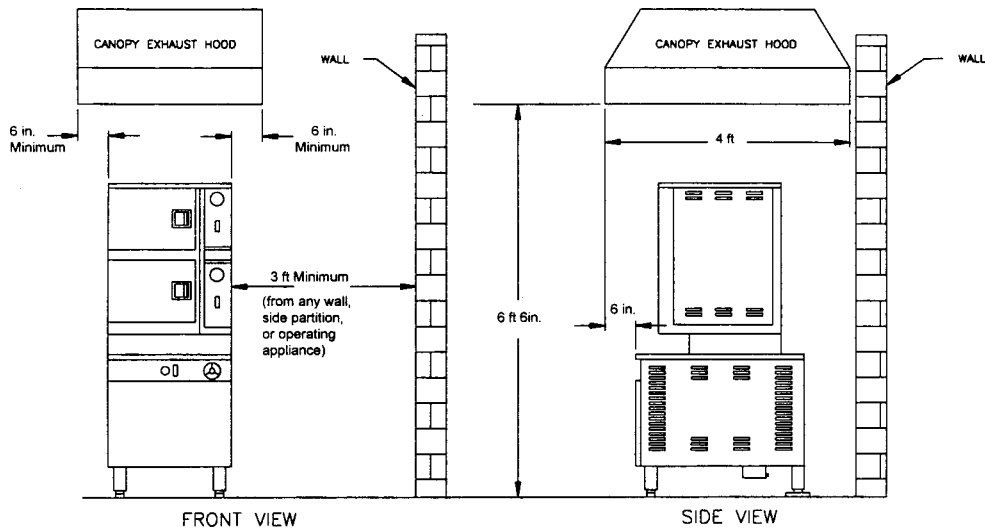

FIG. 3 Equipment Configuration

source or a steam coil steam generator, there shall be a pressure gage and steam flow meter to verify that the manufacturer's specified steam requirements are met. For electric installations, a voltage regulator may be required during tests if the voltage supply is not within  $\pm 2.5\%$  of the manufacturer's nameplate voltage.

9.3 For an electric steam cooker, confirm (while the steam cooker elements are energized) that the supply voltage is within  $\pm 2.5\%$  of the operating voltage specified by the manufacturer. The test voltage shall be recorded for each test.

NOTE 2—If an electric steam cooker is rated for dual voltage (for example, 208/240 V), the voltage selected by the manufacturer or tester, or both, shall be reported. If an oven is designed to operate at two voltages without a change in the resistance of the heating elements, the performance of the oven (for example, preheat time) may differ at the two voltages.

9.4 For a gas steam cooker, adjust (during a boiler preheat) the gas pressure downstream from the appliance pressure regulator to within  $\pm 2.5\%$  of the operating manifold pressure specified by the manufacturer. Also make adjustments to the appliance following the manufacturer's recommendations for optimizing combustion.

9.5 Install a flow meter (6.10) to the steam cooker water inlet such that total water flow to the appliance (both boiler supply water and condensate cooling water) is measured.

9.6 Install a pressure gage (6.6) to measure boiler pressure.

9.7 Install a temperature sensor (6.13) such that it is immersed in the condensate water path just as it exits the steam cooker.

9.8 Tape a temperature sensor (6.13) firmly to the surface of a section of the metal tubing through which city water enters the boiler.

**10. Procedure**

NOTE 3—Prior to starting these tests, the tester should read the operating manual and fully understand the operation of the appliance.

**10.1 General:**

10.1.1 For gas steam cookers, the following shall be obtained and recorded for each run of every test.

- 10.1.1.1 Higher heating value,
- 10.1.1.2 Standard gas conditions for calculation in 11.3.2,
- 10.1.1.3 Measured gas temperature,
- 10.1.1.4 Measured gas pressure,
- 10.1.1.5 Barometric pressure, and
- 10.1.1.6 Measured peak input rate during or immediately prior to test.

NOTE 4—The preferred method for determining the heating value of gas supplied to the steam cooker under test is by using a calorimeter or gas chromatography in accordance with accepted laboratory procedures. It is recommended that all testing be performed with gas having a heating value between 1000 and 1075 Btu/ft<sup>3</sup> (37 300 to 40 100 kJ/m<sup>3</sup>).

10.1.2 For gas steam cookers, energy calculations shall be in accordance with 11.3.

10.1.3 For gas steam cookers, electric energy consumption shall also be measured and added to gas energy for all tests, with the exception of the maximum energy input rate test (10.2). If it is clear (from the equipment manual or another source of information) that the electric energy consumption rate is constant during a test, then an instantaneous power measurement can be made when convenient during that test, rather than continuous monitoring of accumulated energy consumption. Energy can be estimated later, based on the power measurement and the duration of the test.

10.1.4 For electric steam cookers, the following shall be obtained and recorded for each run of every test.

- 10.1.4.1 Voltage while elements are energized, and
- 10.1.4.2 Measured peak input rate during or immediately prior to test.

10.1.5 For steam cookers that use either a direct external potable steam source or a steam coil steam generator, the supplied steam pressure and average flow rate shall be recorded for each run of every test.

10.1.6 For each run of every test, confirm that the peak input rate is within  $\pm 5\%$  of rated nameplate input. If the difference is greater than 5%, testing shall be terminated and the manufacturer contacted. The manufacturer may make appropriate changes or adjustments to the steam cooker.

10.1.7 If a steam cooker is able to operate in more than one pressure mode (for example, both low pressure and pressure-less), the tester shall record the operating mode selected for testing and conduct all tests herein using the same operating mode.

#### 10.2 *Maximum Energy Input Rate:*

10.2.1 This step applies to gas steam cookers only. (For electric steam cookers, proceed directly to step 10.2.2, and for steam coil steam cookers, proceed directly to step 10.2.3.) For some gas appliances, the maximum energy input rate changes as the orifices heat up. If the steam cooker under test is gas powered, conduct a boiler fill and preheat, then immediately purge the boiler and proceed to step 10.2.3.

10.2.2 This step applies to electric steam cookers only. Monitor power during a steam cooker operation where the maximum power is drawn. Proceed directly to step 10.2.4.

10.2.3 Allow the boiler(s) or reservoir to fill with water. As soon as the boiler(s) or reservoir is (are) full, start the preheat (some boilers may start automatically after filling). Begin monitoring energy consumption and time as soon as all the burners, elements, or steam coils energize. Continue until the first burner, element, or steam coil turns off. Record final time and energy.

10.2.4 In accordance with 11.4, determine the maximum energy input rate for the steam cooker under test. Report the measured input rate and confirm that it is within 5 % of the rated nameplate input. If the difference is greater than 5 %, testing shall be terminated and the manufacturer contacted. The manufacturer may make appropriate changes or adjustments to the steam cooker.

#### 10.3 *Preheat Energy Consumption and Duration:*

10.3.1 Fill the boiler or reservoir. Record the time required to fill it. Monitor the average temperature of the water as it enters the boiler or reservoir. If the average temperature was not  $70 \pm 5^\circ\text{F}$  ( $21 \pm 3^\circ\text{C}$ ), then allow the filled boiler or reservoir to sit until the temperature is within that range. Temperature of the water in the boiler can be estimated by measuring the boiler surface temperature using a surface temperature probe (6.17).

10.3.2 Record the temperature of the water in the boiler or reservoir. Start the preheat. Begin monitoring energy consumption and time as soon as the boiler is turned on. For a gas steam cooker, the recorded preheat time shall include any delay between the time the unit is turned on and when the burners actually ignite. For a gas steam cooker, measure and record any electric energy consumption as well. Preheat is judged complete when the primary burners, elements, or steam coil cycles off or when the steamer compartment reaches  $210^\circ\text{F}$  (boilerless steamers). Record preheat energy consumption, duration, and final pressure (if applicable).

10.3.3 In accordance with 11.5, report preheat energy consumption and duration.

#### 10.4 *Idle Energy Rate:*

10.4.1 If the steamer is equipped with a standby (idle) mode, then set the appliance controls to this mode. Allow the steamer to idle, that is, operate in standby for at least 60 min after the preheat. Then commence monitoring the elapsed time and the energy consumption of the steam cooker while it is

operated under this idle condition for a minimum of 2 h. For gas steam cookers, monitor electric energy in addition to gas consumption.

10.4.1.1 If there is a separate boiler for each compartment, then apply this test (and report an idle rate) for each compartment separately and then for all compartments simultaneously.

10.4.2 This step applies to non-atmospheric boilers only. In addition to monitoring total energy for the test period, record the quantity of energy consumed during each individual cycle for three cycles of the boiler. Record the average of these values as the energy required to raise the boiler from minimum operating pressure/temperature to maximum pressure/temperature. This value is used in the green pea load and potato load energy efficiency calculations.

10.4.3 In accordance with 11.6, calculate and report idle energy rate(s).

#### 10.5 *Pilot Energy Rate (Gas Models with Standing Pilots):*

10.5.1 With the pilot lit and the boiler off, record time and gas consumption for a minimum of 8 h. In accordance with 11.7, calculate and report pilot energy rate.

#### 10.6 *Green Pea Load Preparation:*

10.6.1 This section outlines preparation of the frozen green peas used in the green pea load cooking energy-efficiency and production-capacity test (10.7).

10.6.2 The number of green pea loads to be prepared depends on which loading scenario is to be performed. There are two loading scenarios: light and heavy. The heavy load is the manufacturer's stated capacity of 12 by 20 by  $2\frac{1}{2}$ -in. (300 by 500 by 65-mm) hotel pans. Consult Table 1 for the number of green pea loads to prepare for the light loading scenarios.

NOTE 5—When the test calls for a less than capacity number of loads for a compartment, the loads should be placed in the most centrally located slots. When symmetry about the center is not possible, then use the upper central slots first. For example, one pan in a four-pan capacity compartment should be located in the second slot from the top. Two loads in a four-pan capacity compartment should be located in the second and third slots from the top (yielding symmetry about the center). One load in a three-pan capacity compartment would be located in the center, and two loads would be located in the top and middle slots. Two pans in a five-pan capacity compartment would be located in the second slot from the top and third slot from the top (center slot).

10.6.3 The perforated hotel pans shall be as specified in 6.14.

10.6.4 Number each pan and record the weight of each of the (empty) pans. The weight of the pan(s) will be the total weight of all pans used for the test.

10.6.5 Load each pan with  $8.0 \pm 0.2$  lb ( $3.6 \pm 0.1$  kg) (see 7.2) of green peas sealed in plastic zip bags. Record the weight of the frozen green peas in each pan. Place the green pea load in the freezer and allow the temperature to stabilize at  $0 \pm 5^\circ\text{F}$  ( $-18 \pm 2^\circ\text{C}$ ). For a 24 h period. The weight of the frozen green peas will be the total weight of the green peas in each of the pan(s).

10.6.6 The water-bath calorimeter shall be as specified in 6.15. Record the weight of the empty calorimeter using the platform balance scale (6.6).

10.6.7 Place 10 lb of potable water for every pan of green peas into the calorimeter drum. (For example, the total weight

**TABLE 1 Number of Loads for Light Loading Scenario**

Light Loading Scenario	
1 Compartment 3 Pan Capacity	1 Pan
1 Compartment 4 Pan Capacity	1 Pan
1 Compartment 5 Pan Capacity	1 Pan
1 Compartment 6 Pan Capacity	1 Pan
2 Compartments 3 Pan Capacity Per Compartment	1 Pan in top compartment None in bottom
2 Compartments 4 Pan Capacity Per Compartment	1 Pan in top compartment None in bottom
2 Compartments 5 Pan Capacity Per Compartment	2 Pans in top compartment None in bottom
2 Compartments 6 Pan Capacity Per Compartment	2 Pans in top compartment None in bottom
2 Compartments 8 Pan Capacity Per Compartment	2 Pans in top compartment None in bottom
3 Compartments 3 Pan Capacity Per Compartment	2 Pans in middle compartment None in top None in bottom
3 Compartments 4 Pan Capacity Per Compartment	2 Pans in middle compartment None in top None in bottom
3 Compartments 5 Pan Capacity Per Compartment	2 Pans in middle compartment None in top None in bottom
3 Compartments 6 Pan Capacity Per Compartment	2 Pans in middle compartment None in top None in bottom
3 Compartments 8 Pan Capacity Per Compartment	2 Pans in middle compartment None in top None in bottom

of water for a heavy load test of a six-pan capacity, steamer would be 10 lb water/pan × 6 pans = 60 lb).

NOTE 6—The initial water temperature for the water-bath need not be 70 ± 5°F (21 ± 3°C). As long as the initial and final temperatures are recorded, the change in water-bath temperature can be obtained.

10.6.8 Record the weight of the water in the water-bath calorimeter.

10.7 *Green Pea Load Cooking Energy Efficiency, Production Capacity, Water Consumption, and Condensate Temperature :*

10.7.1 This procedure applies to two possible loading scenarios: light and heavy. Repeat each loading scenario a minimum of three times. Additional test runs may be necessary to obtain the required precision for the reported test results (Annex A1). The reported values of cooking energy efficiency,

production capacity, condensate temperature, and water consumption shall be the average of the replications (runs).

10.7.2 Prepare the frozen green pea load(s) in accordance with 10.6. Record the weight of the empty pan(s) and the weight of the green pea load(s).

10.7.3 Measure and record the average temperature of the green peas by probing the content of the sealed bags. Confirm that they are at 0 ± 5°F (−18 ± 3°C).

10.7.4 Choose a cooking time either based on the manufacturer’s recommendation or by experience.

10.7.5 Allow the steam cooker to sit idle, that is, stabilize in a ready-to-cook state (boiler(s) on) for a minimum of 1 h. If the manufacturer recommends leaving the cooking cavity doors open when not cooking, then leave them open during the stabilization period and record the door position during the stabilization period.

NOTE 7—The steamer shall be stabilized in the same operating mode that will be used for the cooking test. If the steamer is to be tested in a reduced-input mode, then the steamer shall be stabilized in the same mode for at least 1 h prior to loading with food product.

10.7.6 After the stabilization period, wait for the burners, elements, or steam coil to cycle on and then off again. This assures that the boiler is at maximum operating pressure/temperature when the efficiency test cooking starts.

10.7.7 Start monitoring time. Transport the green pea loads to the testing location. Empty the bagged green peas into the pan(s). Open one steam compartment, load the pan(s) into it, close it, and start steam to it. Open the next steam compartment (if applicable), load it, close it, start it, and note the starting time. Open, load, close and start the last compartment (if applicable). After starting steam to the first compartment, commence monitoring energy consumption, water consumption, and condensate temperature. For gas steam cookers, monitor and record the electric energy as well as gas consumption. The total loading time (the time from opening the first compartment to closing and starting the last compartment) shall be the total of 5 s per compartment plus 5 s for each load used. (For example, the total loading time for a heavy load test of a six-pan capacity, two-compartment steam cooker would be 5 s/compartment × 2 compartments + 5 s/load × 6 loads = 40 s).

NOTE 8—Care shall be taken to minimize heat gain by the frozen green pea loads on the way from the freezer to the steam cooker. During that time they shall be isolated from any warmer surface by R10 or better insulation. PG&E found 2 in. (50 mm) thick square-edged polystyrene boards to be convenient as an insulating surface.

NOTE 9—For gas steamers, the “electric energy rate” during the heavy load test will be reported separately from the gas “cooking energy rate.” The two values are reported separately so that the respective fuel prices may be applied to estimate energy costs.

NOTE 10—The boiler is at maximum pressure when the test starts, but it may be at a lower pressure at the end of the test. This difference between the initial and final energy content (pressure/temperature) of the boiler must be added back to the boiler to correctly calculate the energy efficiency. Maximum, minimum and final boiler pressure is measured so that this energy deficit can be estimated. There are situations where the measurement of pressure in step 10.7.8 is not necessary, as noted in steps 10.7.10 and 10.7.12.

NOTE 11—The average condensate temperature for the final 3 min of the run is what will be reported, rather than the average over the entire run;

therefore, condensate temperature monitoring need not begin immediately upon commencement of the test run.

10.7.8 For three cycles of the boiler pressure near the end of the test, measure the maximum and minimum pressures. Record the average maximum and average minimum boiler pressure.

10.7.9 Terminate steam to the compartments as the predetermined cooking time elapses for each compartment. After stopping steam to the last compartment, record the final time, water consumption, and average condensate temperature.

10.7.10 If the boiler is on when the cooking time for the last compartment has elapsed, continue to monitor energy consumption until the primary burners, elements, or steam coils cycle off. Record final energy. Note that the initial and final energy content of the boiler is the same; therefore, the pressure measurements in step 10.7.8 are not needed.

10.7.11 If the boiler is not on when the last compartment cooking time elapsed, proceed to one of the next two conditional steps (10.7.12 or 10.7.13).

10.7.12 Perform this step if the boiler pressure is controlled by a pressure switch that can be manually actuated. Otherwise, proceed directly to step 10.7.13. When the time for the last compartment has elapsed, continue to monitor energy consumption and actuate the pressure switch. This returns the boiler energy content to the initial test condition; therefore, the pressure measurements in step 10.7.8 and the energy measurements in step 10.4.2 are not necessary. Record the final energy.

10.7.13 Perform this step if the boiler pressure control cannot be manually actuated. When the cooking time for the last compartment has elapsed, record the final energy and the boiler pressure (used to calculate the energy deficit of the boiler, as described in Note 10).

10.7.14 Record the initial temperature of the water-bath calorimeter immediately before the cook time elapsed. The unloading time shall be the same as the loading time. Remove the calorimeter lid and empty the cooked green pea load(s) into the water-bath calorimeter. Replace the lid on the water-bath calorimeter.

10.7.15 Using the stirrer, agitate the content for 1 min, then allow the contents of the water-bath calorimeter to stabilize for 5 min. Repeat the agitation and stabilization process every 5 min until the bulk temperature fluctuation is less than  $\pm 0.1^\circ\text{F}$  within a 5 min period. Record this temperature as the final bulk temperature.

10.7.16 Record the total weight of the water-bath calorimeter containing the cooked green peas and water with the platform balance scale. This will be used to determine the weight of the cooked green peas.

10.7.17 In accordance with 11.8.2, calculate the final cooked bulk temperature of the green peas. The cook temperature must be  $180 \pm 5^\circ\text{F}$  ( $82 \pm 3^\circ\text{C}$ ) for the test run. If the temperature does not fall within this range, the test must be repeated with an adjusted cook time.

10.7.18 If the temperature is within the range, prepare the next frozen green pea load (10.6) and the water-bath calorimeter, unless this was the final run (Run No. 3), and perform the test again (10.7).

10.7.19 Confirm that the multi-test (three run) average final pea temperature is  $180 \pm 2^\circ\text{F}$  ( $82 \pm 1^\circ\text{C}$ ). If the average final pea temperature does not fall within this range, then repeat 10.7.2-10.7.18 with an appropriately adjusted cook time to achieve this average temperature.

10.7.20 Calculate the cooking energy efficiency, production capacity, water consumption, and average condensate temperature in accordance with 11.8 and report the results as the average of three replications.

#### 10.8 *Whole Potato Load Preparation:*

10.8.1 This section outlines preparation of the potato loads used in the whole potato load cooking energy efficiency and production capacity test (10.9). The number of potato loads to be prepared depends on which loading scenario is to be performed. There are two loading scenarios: light and heavy. The heavy load is the manufacturer's stated capacity of 12 by 20 by  $2\frac{1}{2}$  in. (300 by 500 by 65 mm) hotel pans. Consult Table 1 for the number of potato loads to prepare for the light loading scenario. For each loading scenario, prepare enough potato loads for a minimum of three runs.

10.8.2 The perforated hotel pans shall be as specified in 6.14. Number each pan and record the weight of each (empty) pan.

10.8.3 Load each pan with  $8.0 \pm 0.2$  lb ( $3.6 \pm 0.1$  kg) of red potatoes (7.3). Each pan shall contain between 48 and 52 red potatoes. Record the actual weight and count of the potato load in each pan.

NOTE 12—If the weight of the potatoes on a pan is outside the  $8.0 \pm 0.2$  lb ( $3.6 \pm 0.1$  kg) weight range specified above, substitute smaller or larger potatoes, as necessary, until the weight of the potatoes on each pan is within the required weight range while maintaining a count of  $50 \pm 2$  potatoes per pan.

#### 10.9 *Whole Potato Load Cooking Energy Efficiency, Production Capacity, Water Consumption, and Condensate Temperature :*

10.9.1 This procedure applies to two possible loading scenarios: light and heavy. Each loading scenario shall be repeated a minimum of three times. Additional test runs may be necessary to obtain the required precision for the reported test results (Annex A1). The reported values of cooking energy efficiency, production capacity, condensate temperature, and water consumption shall be the average of the replications (runs).

10.9.2 Prepare the potato loads in accordance with 10.8. Record the weight of the empty pans, the weight of the potato load in each pan, and the number of potatoes in each pan. Record the number of potato loads to be used for each run.

10.9.3 Choose a cooking time either based on the manufacturer's recommendation or by experience.

10.9.4 Randomly select potatoes from each pan for temperature monitoring. For single-pan tests (light loads), record the temperature of at least 15 potatoes. For two to six pan loads, record the temperature of at least five potatoes per pan. For loads of seven or more pans, record the temperature of at least three potatoes per pan.

10.9.5 Shortly before each test run, place a hypodermic-style thermocouple probe into the center of the randomly-selected potatoes. Secure each thermocouple lead wire in such



a manner that its junction will remain at the center of the potato throughout the cooking period. The temperature of the potatoes at the start of each test shall be  $75 \pm 5^\circ\text{F}$  ( $24 \pm 3^\circ\text{C}$ ).

NOTE 13—Steamers that operate with the cooking compartment under pressure or vacuum may not function properly with thermocouples passing through the door seal. For these steamers, it may not be possible to monitor potato temperature during the cooking cycle.

10.9.6 Allow the steam cooker to stabilize in a ready-to-cook state (boiler on) for a minimum of 1 h. If the manufacturer recommends leaving the cooking cavity doors open when not cooking, leave them open during the stabilization period. Record the door position during the stabilization period. Fig. 4 shows the cooking energy efficiency test sequence.

NOTE 14—The steamer shall be stabilized in the same operating mode that will be used for the cooking test. If the steamer is to be tested in a reduced-input mode, then the steamer shall be stabilized in the same mode for at least 1 h prior to loading with food product.

10.9.7 After the stabilization period, wait for the burners, elements, or steam coil to cycle on and then off again. This assures that the boiler is at maximum operating pressure/temperature when the efficiency test cooking starts.

NOTE 15—The boiler is at maximum pressure when the test starts, but it may be at a lower pressure at the end of the test. This difference between the initial and final energy content (pressure/temperature) of the boiler must be added back to the boiler to correctly calculate the energy efficiency. Maximum, minimum and final boiler pressure is measured so that this energy deficit can be estimated. There are situations where the measurement of pressure in step 10.9.9 is not necessary, as noted in steps 10.9.11 and 10.9.13.

10.9.8 Start monitoring time. Open one steam compartment, load it with potato loads, close it, and start steam to it. Note the starting time for that compartment. Open the next steam compartment (if applicable), load it, close it, start it, and note the starting time. Open, load, close, start, and note starting time of the last compartment (if applicable). After starting steam to the first compartment, commence monitoring energy consumption, water consumption, potato temperature and condensate temperature. For gas steam cookers, monitor and record electric energy as well as gas consumption. The total loading time (the time from opening the first compartment to closing and starting the last compartment) shall be the total of 5 s per compartment plus 5 s for each load used (for example, the total

loading time for a heavy load test of a six-pan capacity, two-compartment steam cooker would be:  $5 \text{ s/compartment} \times 2 \text{ compartments} + 5 \text{ s/load} \times 6 \text{ loads} = 40 \text{ s}$ ).

10.9.9 For three cycles of the boiler pressure near the end of the test, measure the maximum and minimum pressures. Record the average maximum and average minimum boiler pressure.

NOTE 16—For gas steamers, the “electric energy rate” during the heavy load test will be reported separately from the gas “cooking energy rate.” The two values are reported separately so that the respective fuel prices may be applied to estimate energy costs.

NOTE 17—The average condensate temperature for the final 5 min of the run is what will be reported, rather than the average over the entire run; therefore, condensate temperature monitoring need not begin immediately upon commencement of the test run.

10.9.10 Terminate steam to the compartments when the average potato temperature reaches  $195 \pm 2^\circ\text{F}$  ( $91 \pm 1^\circ\text{C}$ ). After stopping steam to the last compartment, record the final time, water consumption, average potato temperature and average condensate temperature.

10.9.11 If the boiler is on when the cooking time for the last compartment has elapsed, continue to monitor energy consumption until the primary burners, elements, or steam coils cycle off. Record the final energy. Note that the initial and final energy content of the boiler is the same; therefore, the pressure measurements in step 10.9.9 are not needed. Proceed directly to step 10.9.15.

10.9.12 If the boiler is not on when the cooking time for the last compartment has elapsed, then proceed to one of the next two conditional steps (10.9.13 or 10.9.14).

10.9.13 Perform this step if the boiler pressure is controlled by a pressure switch that can be manually actuated. Otherwise, proceed directly to step 10.9.14. When the cooking time for the last compartment has elapsed, continue to monitor energy consumption and actuate the pressure switch. This returns the boiler energy content to the initial test condition; therefore, the pressure measurements in step 10.9.9, and the energy measurements in step 10.4.2 are not necessary. Record the final energy. Proceed directly to step 10.9.15.

10.9.14 Perform this step if the boiler pressure control cannot be manually actuated. When the cooking time for the last compartment has elapsed, record the final energy and the

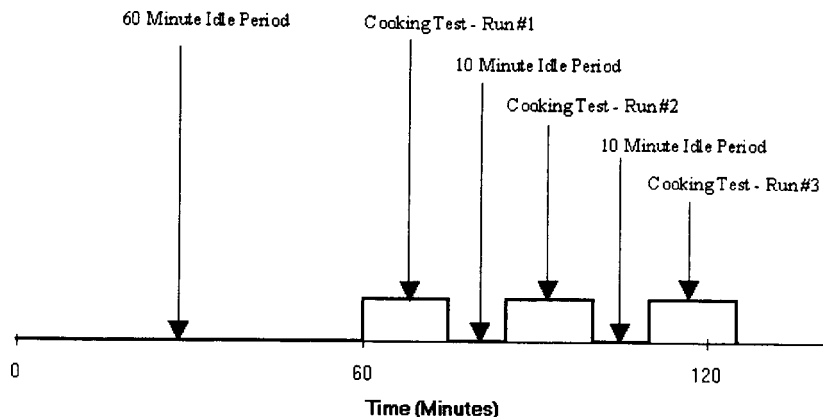

FIG. 4 Cooking Energy Efficiency Test Sequence

boiler pressure (used to calculate the energy deficit of the boiler, as described in Note 15).

10.9.15 Confirm the cooked potato temperature by measuring and recording the temperature of five randomly selected potatoes for each pan. Ensure that each quadrant in each pan is represented. Temperature shall be measured immediately after cooking is terminated. The last temperature taken shall be no more than 3 min after cooking is terminated. The average bulk temperature (including monitored and spot-checked potatoes) must be  $195 \pm 2^\circ\text{F}$  ( $91 \pm 1^\circ\text{C}$ ). If the temperature does not fall in this range, the test must be repeated with an adjusted cook time.

10.9.16 Remove the potato loads, and unless this was the final run (Run No. 3), start timing the 10 min stabilization period before the next run (see Fig. 4). Return to step 10.9.7.

10.9.17 In accordance with 11.9, calculate and report cooking energy efficiency, production capacity, water consumption, and average condensate temperature. After performing this test (10.9) three times for each loading scenario, report results as the average of the replications.

#### 10.10 *Ice Load Cooking Uniformity:*

10.10.1 The cooking uniformity test must be repeated three times. The reported final pan temperatures shall be the average of the replications (runs).

10.10.2 The number of ice loads required depends on the steamer capacity. The heavy load is the manufacturer's stated capacity of 12 by 20 by 2½-in. (300 by 500 by 65-mm) hotel pans. Prepare enough ice loads for three runs.

10.10.3 The solid hotel pans shall be as specified in 6.19.

10.10.4 Number each pan and record the weight of each of the (dry) pans.

10.10.5 Fill the pans with enough water such that there will be  $8.0 \pm 0.2$  lb ( $3.6 \pm 0.1$  kg) of ice after freezing (some water will evaporate during freezing, especially if hotel pan lids are not used). Accurate measurement of the weight of the pans plus the water prior to freezing is not required since they will be weighed again just prior to testing.

10.10.6 Freeze the loads to  $0 \pm 5^\circ\text{F}$  ( $-18 \pm 2^\circ\text{C}$ ).

10.10.7 Record the initial average ice load temperature. Confirm that they are at  $0 \pm 5^\circ\text{F}$  ( $-18 \pm 3^\circ\text{C}$ ).

10.10.8 Allow the steam cooker to stabilize in a ready-to-cook state (boiler(s) on) for a minimum of 1 h. If the manufacturer recommends leaving the cooking cavity doors open when not cooking, leave them open during the stabilization period and record the door position during the stabilization period.

10.10.9 Near the end of the stabilization period, remove each pan from the freezer, remove the lid, and weigh. Record the weight of each ice load (including the pan itself) for that run. Record the dry pan weights as determined in 10.10.4. After the stabilization period, wait for the burners, elements, or steam coil to cycle on and then off again (if applicable). This ensures that the boiler is at maximum operating pressure and temperature when the cooking uniformity test cooking starts.

10.10.10 Start monitoring time. Open one steam compartment, load it with ice loads, close it, and start steam to it. Open the next steam compartment (if applicable), load it, close it, and start it. Open, load, close, and start the last compartment (if

applicable). After starting steam to the first compartment, commence monitoring the temperature of the ice loads. The total loading time (the time from opening the first compartment to closing and starting the last compartment) shall be the total of 5 s per compartment plus 5 s for each ice load used. (For example, the total loading time for a heavy load test of a six-pan capacity, two-compartment steam cooker would be  $5 \text{ s/compartment} \times 2 \text{ compartments} + 5 \text{ s/ice load} \times 6 \text{ ice loads} = 40 \text{ s}$ .)

NOTE 18—Care shall be taken to minimize heat gain by the ice loads on the way from the freezer to the steam cooker. During that time, they shall be isolated from any warmer surface by R10 or better insulation. PG&E found 2-in. (50-mm) thick square-edged polystyrene boards to be convenient as an insulating surface.

NOTE 19—Care shall be taken to minimize heat loss out of the cooking compartment where the sensor leads pass under the door gasket. PG&E found that heat loss was not significant as long as the sensor leads were not bunched or paired as they passed under the door gasket.

10.10.11 When the first pan reaches  $170^\circ\text{F}$  ( $77^\circ\text{C}$ ), stop the steam to that compartment. If there are two or more compartments under test, continue to monitor the ice load temperature of the other compartments, stopping steam to the compartments as the first pan reaches  $170^\circ\text{F}$  ( $77^\circ\text{C}$ ). When the last (or only) compartment's first pan reaches  $170^\circ\text{F}$  ( $77^\circ\text{C}$ ), terminate steam to the compartment and record total elapsed time.

10.10.12 Remove the ice loads, and unless this was the final run (Run No. 3), start timing the 10-min stabilization period before the next run. Return to 10.10.5.

10.10.13 In accordance with 11.10, calculate and report the average cook time and cooking uniformity. After performing this test at least three times, report the results as the average of the replications.

## 11. Calculations and Reporting

### 11.1 *Test Steam Cooker:*

11.1.1 Using Specification F 1217 classifications, summarize the physical and operating characteristics of the steam cooker. Use additional text to describe any design characteristics that may facilitate the audience's interpretation of the test results.

### 11.2 *Apparatus and Procedure:*

11.2.1 Confirm that the testing apparatus conformed to all of the specifications in Section 9. Describe any deviations from those specifications.

### 11.3 *Gas and Steam Energy Calculations:*

11.3.1 For gas steam cookers, electric energy consumption shall be added to gas energy for all tests, with the exception of the maximum energy input rate test (10.2).

11.3.2 For gas steam cookers, energy consumed ( $E_{\text{gas}}$ ) shall be calculated using the following formula:

$$E_{\text{gas}} = HV \times V \quad (1)$$

where:

- $E_{\text{gas}}$  = energy consumed by steam cooker,
- $HV$  = higher heating value  
= energy content of gas measured at standard conditions, Btu/ft<sup>3</sup> (kJ/m<sup>3</sup>), and
- $V$  = actual volume of gas corrected to standard conditions, ft<sup>3</sup>(m<sup>3</sup>)