



Designation: D 6110 – 04

Standard Test Method for Determining the Charpy Impact Resistance of Notched Specimens of Plastics¹

This standard is issued under the fixed designation D 6110; the number immediately following the designation indicates the year of original adoption or, in the case of revision, the year of last revision. A number in parentheses indicates the year of last reapproval. A superscript epsilon (ϵ) indicates an editorial change since the last revision or reapproval.

1. Scope*

1.1 This test method is used to determine the resistance of plastics to breakage by flexural shock as indicated by the energy extracted from standardized (see Note 1) pendulum-type hammers, mounted in standardized machines, in breaking standard specimens with one pendulum swing. This test method requires specimens to be made with a milled notch (see Note 2). The notch produces a stress concentration which promotes a brittle, rather than a ductile, fracture. The results of this test method are reported in terms of energy absorbed per unit of specimen width (see Note 3).

NOTE 1—The machines with pendulum-type hammers have been standardized in that they must comply with certain requirements including a fixed height of hammer fall, which results in a substantially fixed velocity of the hammer at the moment of impact. Hammers of different initial energies (produced by varying their effective weights), however, are recommended for use with specimens of different impact resistance. Moreover, manufacturers of the equipment are permitted to use different lengths and constructions of pendulums with possible differences in pendulum rigidities resulting (see Section 5). Be aware that other differences in machine design do exist.

NOTE 2—The specimens are standardized in that they have a fixed length and fixed depth, however, the width of the specimens is permitted to vary between limits. One design of milled notch is allowed. The notch in the specimen serves to concentrate the stress, minimize plastic deformation, and direct the fracture to the part of the specimen behind the notch. Scatter in energy-to-break is thus reduced. Because of differences in the elastic and viscoelastic properties of plastics, however, response to a given notch varies among materials.

NOTE 3—Caution must be exercised in interpreting the results of this test method. The following testing parameters have been shown to affect test results significantly: method of specimen fabrication, including but not limited to processing technology, molding conditions, mold design, and thermal treatment; method of notching; speed of notching tool; design of notching apparatus; quality of the notch; time between notching and test; test specimen thickness; test specimen width under notch; and environmental conditioning.

1.2 *This standard does not purport to address all of the safety concerns, if any, associated with its use. It is the responsibility of the user of this standard to establish appro-*

priate safety and health practices and determine the applicability of regulatory limitations prior to use.

NOTE 4—This standard resembles ISO 179 in title only. The content is significantly different.

2. Referenced Documents

2.1 ASTM Standards:²

- D 618 Practice for Conditioning Plastics for Testing
- D 647 Practice for Design of Molds for Test Specimens of Plastic Molding Materials³
- D 883 Terminology Relating to Plastics
- D 4000 Classification System for Specifying Plastic Materials
- D 4066 Classification System for Nylon Injection and Extrusion Materials
- D 5942 Test Method for Determination of Charpy Impact Strength
- D 5947 Test Methods for Physical Dimensions of Solid Plastics Specimens
- E 691 Practice for Conducting an Interlaboratory Test Program to Determine the Precision of Test Methods

3. Terminology

3.1 *Definitions*—For definitions related to plastics, see Terminology D 883.

4. Summary of Test Method

4.1 A notched specimen is supported as a horizontal simple beam and is broken by a single swing of the pendulum with the impact line midway between the supports and directly opposite the notch.

5. Significance and Use

5.1 Before proceeding with this test method, refer to the material specification for the material being tested. Any test specimen preparation, conditioning, dimensions and testing parameters required by the materials specification shall take

¹ This test method are under the jurisdiction of ASTM Committee D20 on Plastics and are the direct responsibility of Subcommittee D20.10 on Mechanical Properties.

Current edition approved March 1, 2004. Published April 2004. Originally approved in 1997. Last previous edition approved in 2002 as D 6110 - 02.

² For referenced ASTM standards, visit the ASTM website, www.astm.org, or contact ASTM Customer Service at service@astm.org. For *Annual Book of ASTM Standards* volume information, refer to the standard's Document Summary page on the ASTM website.

³ *Discontinued 1994; Replaced by D 1896, D 3419, D 3641, D 4703, D 5227.*

*A Summary of Changes section appears at the end of this standard.

precedence over those required by this test method. Table 1 of Classification D 4000 lists the ASTM materials standards that currently exist. If there is no material specification, then the requirements of this test method apply.

5.2 The excess energy pendulum impact test indicates the energy to break standard test specimens of specified size under stipulated conditions of specimen mounting, notching (stress concentration), and pendulum velocity at impact.

5.3 For this test method, the energy lost by the pendulum during the breakage of the specimen is the sum of the energies required to initiate fracture of the specimen; to propagate the fracture across the specimen; to throw the free ends of the broken specimen (toss energy); to bend the specimen; to produce vibration in the pendulum arm; to produce vibration or horizontal movement of the machine frame or base; to overcome friction in the pendulum bearing and in the excess energy indicating mechanism, and to overcome windage (pendulum air drag); to indent or deform, plastically, the specimen at the line of impact; and to overcome the friction caused by the rubbing of the striking nose over the face of the bent specimen.

NOTE 5—The toss energy, or the energy used to throw the free ends of the broken specimen, is suspected to represent a very large fraction of the total energy absorbed when testing relatively dense and brittle materials. No procedure has been established for estimating the toss energy for the Charpy method.

5.4 For tough, ductile, fiber-filled, or cloth-laminated materials, the fracture propagation energy is usually large compared to the fracture initiation energy. When testing these materials, energy losses due to fracture propagation, vibration, friction between the striking nose and the specimen has the potential to become quite significant, even when the specimen is accurately machined and positioned, and the machine is in good condition with adequate capacity (see Note 6). Significant energy losses due to bending and indentation when testing soft materials have also been observed.

NOTE 6—Although the frame and the base of the machine should be sufficiently rigid and massive to handle the energies of tough specimens without motion or excessive vibration, the pendulum arm cannot be made very massive because the greater part of its mass must be concentrated near its center of percussion at its striking nose. Locating the striking nose precisely at the center of percussion reduces the vibration of the pendulum arm when used with brittle specimens. Some losses due to pendulum arm vibration (the amount varying with the design of the pendulum) will occur with tough specimens even when the striking nose is properly positioned.

5.5 In a well-designed machine of sufficient rigidity and mass the losses due to vibration and friction in the pendulum bearing and in the excess energy indicating mechanism should be very small. Vibrational losses are observed when wide specimens of tough materials are tested in machines of insufficient mass, or in machines that are not securely fastened to a heavy base.

5.6 Since this test method permits a variation in the width of the specimens and since the width dictates, for many materials, whether a brittle, low-energy break (as evidenced by little or no drawing down or necking and by a relatively low energy absorption) or a ductile, high-energy break (as evidenced by considerable drawing or necking down in the region behind the notch and by a relatively high energy absorption) will occur, it

is necessary that the width be stated in the specification covering that material and that the width be stated along with the impact value.

5.7 This test method requires that the specimen break completely. Results obtained when testing materials with a pendulum that does not have sufficient energy to complete the breaking of the extreme fibers and toss the broken pieces shall be considered a departure from standard and should not be reported as a standard result. Impact values cannot be directly compared for any two materials that experience different types of failure.

5.8 The value of this impact test method lies mainly in the areas of quality control and materials specification. If two groups of specimens of supposedly the same material show significantly different energy absorptions, critical widths, or critical temperatures, it is permitted to assume that they were made of different materials or were exposed to different processing or conditioning environments. The fact that a material shows twice the energy absorption of another under these conditions of test does not indicate that this same relationship will exist under another set of test conditions.

6. Apparatus

6.1 *Pendulum Impact Machine*—The machine shall consist of a massive base on which are mounted a pair of supports for holding the specimen and to which is connected, through a rigid frame and bearings, one of a number of pendulum-type hammers having an initial energy suitable for use with the particular specimen to be tested (or one basic pendulum designed to accept add-on weights), plus a pendulum holding and releasing mechanism and a mechanism for indicating the excess energy remaining in the pendulum after breaking specimen. The specimen anvil, pendulum, and frame shall be sufficiently rigid to maintain correct alignment of the striking edge and specimen, both at the moment of impact and during the propagation of the fracture, and to minimize energy losses due to vibration. The base shall be sufficiently massive so that the impact will not cause it to move. The machine shall be designed, constructed, and maintained so that energy losses due to pendulum air drag (windage), friction in the pendulum bearings, and friction and inertia in the excess energy indicating mechanism are held to a minimum.

6.1.1 *Pendulum*—The simple pendulum shall consist of a single or multi-membered arm with a bearing on one end and a head, containing the striking nose, on the other. Although a large proportion of the mass of the pendulum should be concentrated in the head, the arm must be sufficiently rigid to maintain the proper clearances and geometric relationships between the machine parts and the specimen and to minimize vibrational energy losses, which are always included in the measured impact value. A machine with a simple pendulum design is illustrated in Fig. 1. Instruments with a compound-pendulum design also have been found to be acceptable for use. A compound-pendulum design is illustrated in Fig. 2.

6.1.1.1 The machine shall be provided with a basic pendulum capable of delivering an energy of 2.7 ± 0.14 J [2.0 ± 0.10 ft-lbf]. This pendulum shall be used for specimens that extract less than 85 % of this energy when breaking a specimen. Heavier pendulums or additional weights designed to

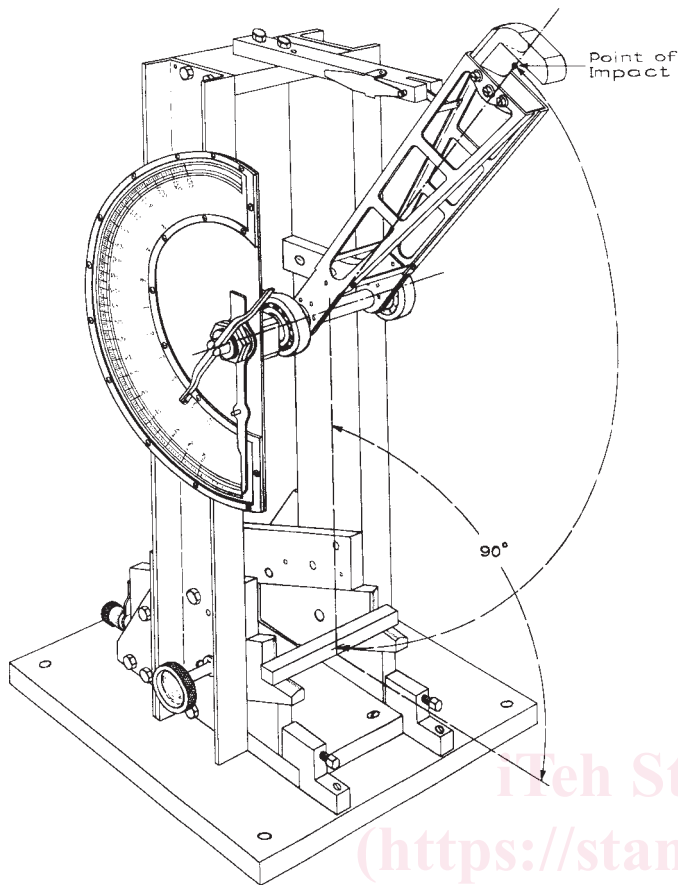

FIG. 1 Simple Beam (Charpy-Type) Impact Machine

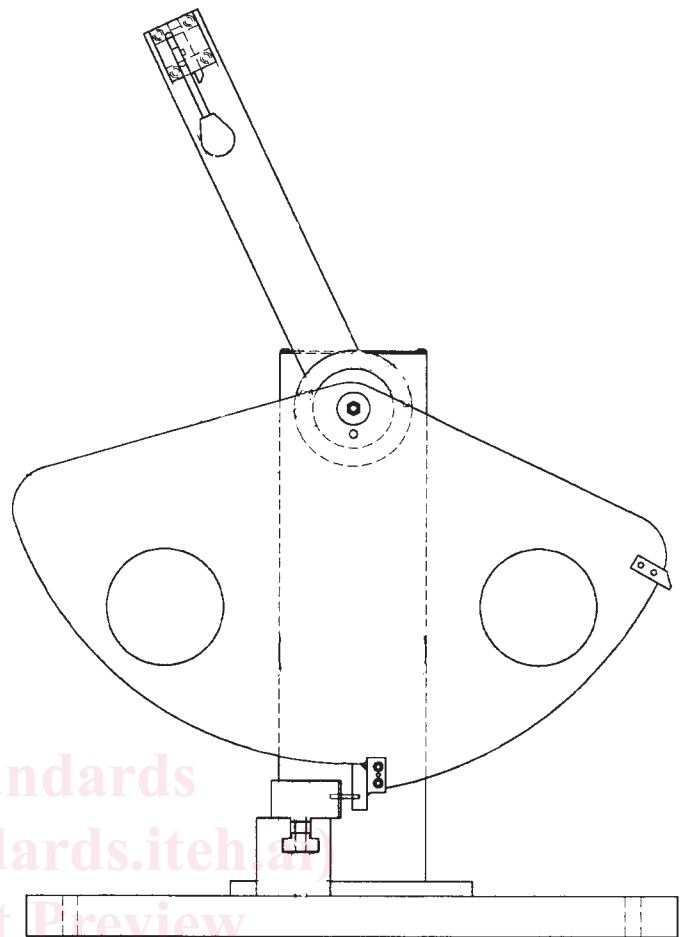

FIG. 2 Example of Compound-Pendulum-Type Machine

attach to the basic pendulum shall be provided for specimens that require more energy to break. A series of pendulums such that each has twice the energy of the next lighter one has been found convenient.

6.1.1.2 The effective length of the pendulum shall be between 0.325 and 0.406 m [12.8 and 16.0 in.] so that the required elevation of the striking nose is obtained by raising the pendulum to an angle between 60 and 30° above the horizontal.

6.1.2 *Striking Edge*—The striking edge (nose) of the pendulum shall be made of hardened steel, tapered to have an included angle of $45 \pm 2^\circ$ and shall be rounded to a radius of 3.17 ± 0.12 mm [0.125 ± 0.005 in.]. The pendulum shall be aligned in such a way that when it is in its free hanging position, the center of percussion of the pendulum shall lie within ± 2.54 mm [0.10 in.] of the middle of the line of contact made by the striking nose upon the face of a standard specimen of square cross section. The distance from the axis of support to the center of percussion is determined experimentally from the period of motion of small amplitude oscillations of the pendulum by means of the following equation:

$$L = (g/4\pi^2) p^2 \quad (1)$$

where:

L = distance from the axis of support to the center of percussion, m,

g = local gravitational acceleration (known to an accuracy of one part in one thousand), m/s^2

π = 3.1416 ($4\pi^2 = 39.48$), and

p = period, in s, of a single complete swing (to and fro) determined from at least 20 consecutive and uninterrupted swings. The angle of swing shall be less than 5° each side of center.

6.1.3 *Pendulum Holding and Releasing Mechanism*—The mechanism shall be designed, constructed, and operated so that it will release the pendulum without imparting acceleration or vibration to the pendulum. The position of the pendulum holding and releasing mechanism shall be such that the vertical height of fall of the striking nose shall be 610 ± 2 mm [24.0 ± 0.005 in.]. This will produce a velocity of the striking nose at the moment of impact of approximately 3.46 m [11.4 ft]/s as determined by the following equation:

$$v = \sqrt{2gh} \quad (2)$$

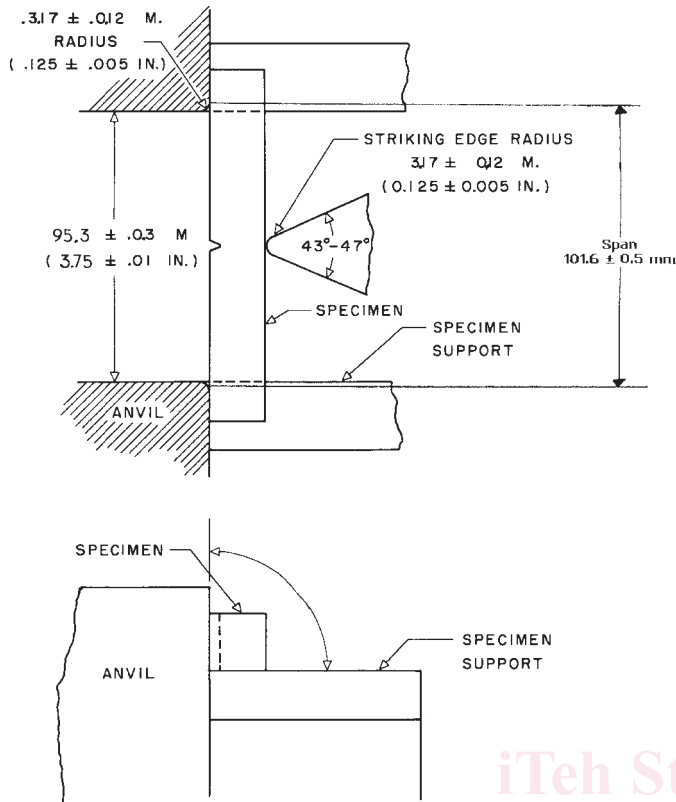

FIG. 3 Relationship of Anvil, Specimen, and Striking Edge to Each Other for Charpy Test Method

where:

- v = velocity of the striking nose at the moment of impact,
- g = local gravitational acceleration, and
- h = vertical height of fall of the striking nose.

This assumes no windage or friction.

6.1.4 *Specimen Supports*—The test specimen shall be supported against two rigid anvils in such a position that its center of gravity and the center of the notch shall lie on tangent to the arc of travel of the center of percussion of the pendulum drawn at the position of impact. The edges of the anvils shall be rounded to a radius of 3.17 ± 0.12 mm [0.125 ± 0.005 in.] and the anvils' lines of contact (span) with the specimen shall be 101.6 ± 0.5 mm [4.0 ± 0.02 in.] apart (see Fig. 3). A jig for positioning the specimen on the supports should be supplied by the machine manufacturer.

NOTE 7—Some machines currently in use employ a 108.0-mm span. Data obtained under these conditions are valid.⁴

6.1.5 *Excess Energy Indicator*—Means shall be provided for determining energy remaining in the pendulum after breaking a specimen. One acceptable method is the use of a pointer and dial mechanism which indicate the height of rise of the pendulum beyond the point of impact in terms of energy removed from that specific pendulum. More modern instruments use an electronic digital display or computer to measure the energy loss and indicate the breaking energy of the

specimen. The indicated remaining energy must be corrected for pendulum bearing friction, pointer friction, pointer inertia, and pendulum windage. The equipment manufacturer should provide graphs or tables to aid in the calculation of the correction friction and windage. Instructions for making these corrections are found in Annex A1 and Annex A2. Many digital indicating systems automatically correct for windage and friction. The equipment manufacturer should be consulted for information on how this is performed.

6.1.6 The calibration procedure in Appendix X2 should be used to establish the accuracy of the equipment. A check of the calibration of an impact machine is difficult to make under dynamic conditions. The basic parameters normally are checked under static conditions. If the machine passes the static tests, then it is assumed to be accurate. Appendix X2, however, also describes a dynamic test for checking certain features of the machine and specimen. For some machine designs, it might be necessary to change the recommended method of obtaining the required calibration measurements. Additional instructions for adjusting a particular machine should be supplied by the manufacturer. Other methods of performing the required checks are acceptable provided that they are proven to result in an equivalent accuracy.

6.2 *Specimen Notching Machine*—Notching shall be done on a milling machine, engine lathe, or other suitable machine tool. A carbide-tipped or industrial diamond-tipped notching cutter is recommended. Both cutter speed and feed rate shall be controllable. Provision for cooling the specimen is recommended. Water and compressed air are suitable coolants for many plastics.

6.2.1 The profile of the cutting tooth or teeth shall be such as to produce a notch in the test specimen of the contour and depth specified in Fig. 4 and in the manner specified in Section 8.

6.2.2 A single-tooth cutter shall be used for notching the specimen, unless it is demonstrated that notches of an equivalent quality are produced with a multi-tooth cutter. Single-tooth cutters are preferred because of the ease of grinding the cutter to the specimen contour and because of the smoother cut on the specimen. The cutting edge shall be ground and honed carefully to ensure sharpness and freedom from nicks and burrs. Tools with no rake and a work relief angle of 15 to 20° have been found satisfactory.

6.3 *Micrometers*—Apparatus for measurement of the width of the specimen shall comply with the requirements of Test Methods D 5947. Apparatus for the measurement of the depth of plastic material remaining in the specimen under the notch shall comply with requirements of Test Methods D 5947, provided however that the one anvil or presser foot shall be a tapered blade conforming to the dimensions given in Fig. 5. The opposing anvil or presser foot shall be flat and conforming to Test Methods D 5947.

7. Test Specimen

7.1 The test specimen shall conform to the dimensions and geometry of Fig. 4, except as modified in accordance with 7.2-7.5. To ensure the correct contour and conditions of the specified notch, all specimens shall be notched in accordance with Section 8.

⁴ Supporting data is available from ASTM Headquarters. Request Research Report RR: D20-1033.

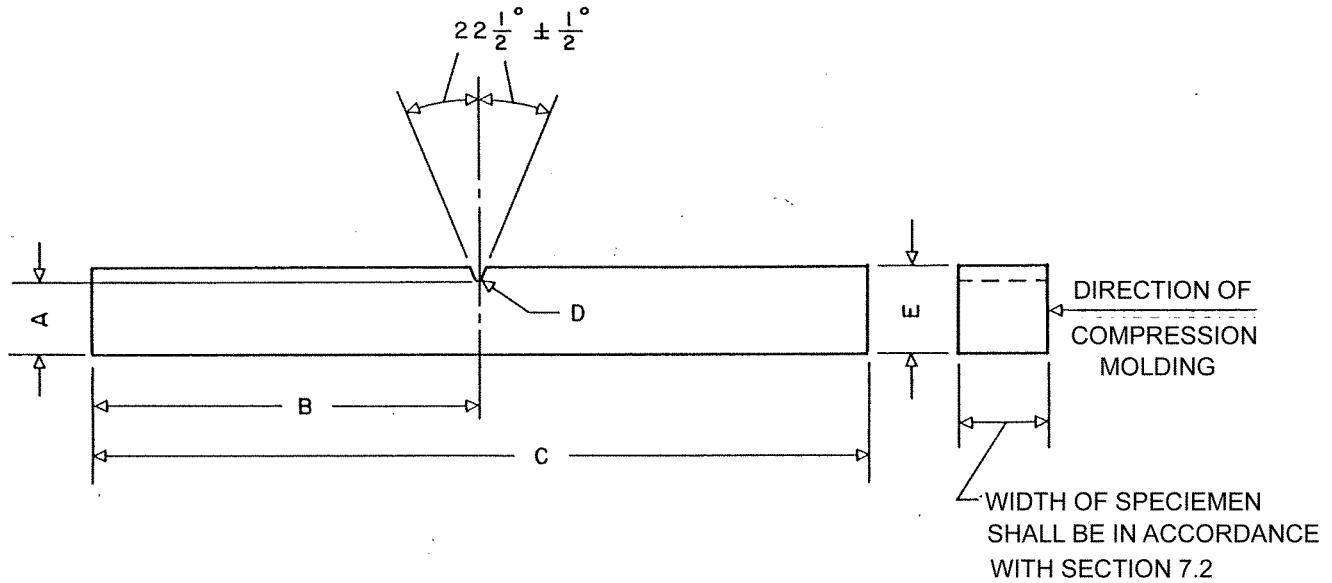

A	10.16 ± 0.05	0.400 ± 0.002
B	63.5 max 61.0 min	2.50 max 2.40 min
C	127.0 max 124.5 min	5.00 min 4.90 min
D	0.25R ± 0.05	0.010R ± 0.002
E	12.70 ± 0.15	0.500 ± 0.006

FIG. 4 Dimensions of Simple Beam, Charpy Type, Impact Test Specimen

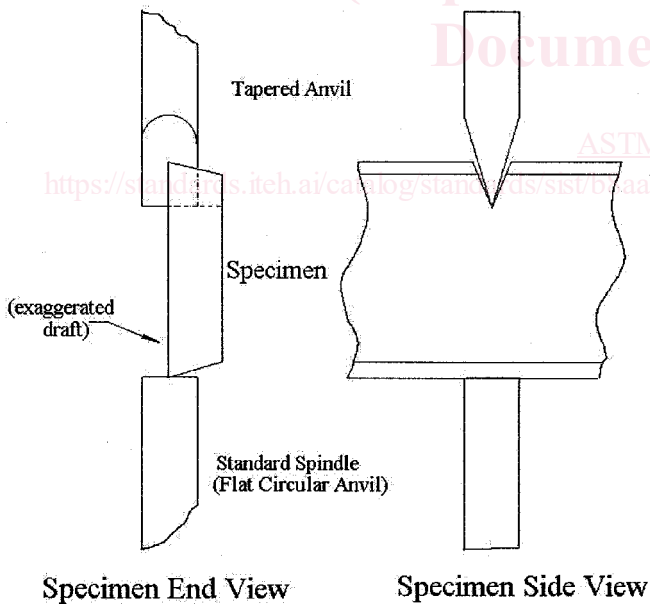

FIG. 5 Notch Depth Measurement on Test Specimens

7.2 Molded specimens shall have a width between 3.00 and 12.7 mm [0.118 and 0.500 in.]. Use the specimen width as specified in the material specification or as agreed upon between the supplier and the customer.

7.2.1 The type of mold and molding machine used and the flow behavior in the mold cavity will influence the strength obtained. It is possible that results from a specimen taken from

one end of a molded bar will give different results than a specimen taken from the other end. Cooperating laboratories should therefore agree on standard molds conforming to Practice D 647, and upon a standard molding procedure for the material under investigation.

7.2.2 A critical investigation of the mechanics of impact testing has shown that tests made upon specimens under 6.35 mm [0.250 in.] in width absorb more energy due to crushing, bending, and twisting than do wider specimens. Specimens 6.35 mm [0.250 in.] or over in width are therefore recommended. The responsibility for determining the minimum specimen width shall be the investigator's, with due reference to the specification for that material.

7.2.3 The impact resistance of a plastic material will be different if the notch is perpendicular to, rather than parallel to, the direction of molding.

7.3 For sheet materials, the specimens shall be cut from the sheet in both the lengthwise and crosswise directions unless otherwise specified. The width of the specimen shall be the thickness of the sheet if the sheet thickness is between 3.00 and 12.7 mm [0.118 and 0.500 in.]. Sheet material thicker than 12.7 mm [0.500 in.] shall be machined down to 12.7 mm [0.500 in.]. It is acceptable to test specimens with a 12.7-mm [0.500-in.] square cross section either edgewise or flatwise as cut from the sheet. When specimens are tested flatwise, the notch shall be made on the machined surface if the specimen is machined on one face only. When the specimen is cut from a thick sheet, notation shall be made of the portion of the thickness of the sheet from which the specimen was cut, for example, center, top, or bottom surface.

7.3.1 The impact resistance of a plastic material will be different if the notch is perpendicular to, rather than parallel to, the grain of an anisotropic bar cut from a sheet. Specimens cut from sheets that are suspected of being anisotropic shall be prepared and tested both lengthwise and crosswise to the direction of the anisotropy.

7.4 The practice of cementing, bolting, clamping, or otherwise combining specimens of substandard width to form a composite test specimen is not recommended and should be avoided since test results will be seriously affected by interface effects or effects of solvents and cements on energy absorption of composite test specimens, or both. If Charpy test data on such thin materials are required, however, and if possible sources of error are recognized and acceptable, the following technique of preparing composites ought to be utilized. The test specimens shall be a composite of individual thin specimens totaling 6.35 to 12.7 mm [0.125 to 0.500 in.] in width. Individual members of the composite shall be aligned accurately with each other and clamped, bolted, or cemented together. Care must be taken to select a solvent or adhesive that will not affect the impact resistance of the material under test. If solvents or solvent-containing adhesives are employed, a conditioning procedure shall be established to ensure complete removal of the solvent prior to test. The composite specimens shall be machined to proper dimensions and then notched. In all such cases, the use of composite specimens shall be noted in the report of test results.

7.5 Each specimen shall be free of twist and shall be bounded by mutually perpendicular pairs of plane, paralleled surfaces and free from scratches, pits, and sink marks. The specimens shall be checked for conformity with these requirements by visual observation against straight edges, squares or flat plates, and by measuring with micrometer calipers. Any specimen showing observable or measurable departure from one or more of these requirements shall be rejected or machined to the proper size and shape before testing. A specimen that has a slight twist to its notched face of 0.05 mm [0.002 in.] at the point of contact with the pendulum striking edge will be likely to have a characteristic fracture surface with considerable greater fracture area than for a normal break. In this case, the energy to break and toss the broken section will be considerably larger (20 to 30 %) than for a normal break.

8. Notching Test Specimens

NOTE 8—When testing a material for the first time, it is necessary to study the effect of all variations in the notching conditions, including cutter dimensions, notch depth, cutter speed, and feed rate. To establish that the notching parameters are suitable, it is advisable to notch several specimens of the material and inspect both the tool entrance and tool exit side of each notched specimen, in accordance with Appendix X1. Adjust the notching machine as required. The specimens used to determine notching conditions shall not be used to make determinations of impact resistance.

8.1 *Notch Dimensions*—The included angle of the notch shall be $45 \pm 1^\circ$ with a radius of curvature at the apex of 0.25 ± 0.05 mm [0.010 ± 0.002 in.]. The plane bisecting the notch angle shall be perpendicular to the face of the test specimen within 2° .

8.1.1 The notch is a critical factor of this test. It is extremely important, therefore, that dimensions of the notch in the specimen are verified. There is evidence that the contour of notches cut in materials of widely differing physical properties by the same cutter will differ. It is sometimes necessary to alter the cutter dimensions in order to produce the required notch contour for certain materials.

8.1.2 Both the notch and the cutter used to make the notch shall be inspected, at a minimum, after every 500 notches. The specimen used to verify the notch shall be the same material that is being prepared for testing. Follow the procedure in Appendix X1 when inspecting and verifying the notch in the specimen. If the angle or radius of the notch does not meet the requirements of 8.1, the cutter should be replaced.

NOTE 9—The contour of the notch made using multi-tooth cutters is checked by measuring the contour of the notch on a strip of soft metal that is inserted between two specimens during the notching process.

NOTE 10—When the same material is being tested on a repetitive basis, and it is demonstrated that the notch in the specimen takes the contour of the tip of the cutter and that the notch meets the contour requirements when checked in accordance with Appendix X1, then it is acceptable to check the contour of the tip of the cutter instead of the notch in the specimen.

8.2 *Notch Depth*—The depth of the plastic material remaining in the specimen under the notch shall be 10.16 ± 0.05 mm [0.400 ± 0.002 in.]. This dimension shall be measured with apparatus in accordance with 6.3. The tapered blade will be fitted to the notch. The specimen will be approximately vertical between the anvils. Position the edge of the non-cavity (wider edge) surface centered on the micrometer's flat circular anvil.

8.3 *Cutter Speed and Feed Rate*—The cutter speed and feed speed should be selected based on the material being tested. The quality of the notch will be adversely affected by thermal deformations and stresses induced during the cutting operation if proper conditions are not selected.⁵ The notching parameters used shall not alter the physical state of the material, such as by raising the temperature of a thermoplastic above its glass transition temperature.

8.3.1 In general, high cutter speeds, slow feed rates, and lack of coolant induce more thermal damage than a slow cutter speed, fast feed speed, and the use of a coolant. Too high a feed speed/cutter speed ratio, however, has been shown to cause impacting and cracking of the specimen. The range of cutter speed/feed ratios possible to produce acceptable notches has been shown to be extended by the use of a suitable coolant.

8.3.1.1 For some thermoplastics, suitable notches have been produced using cutter speeds from 54 to 150 m/min and a feed rate of 89 to 160 mm/min without a water coolant. Satisfactory notches also have been produced using the same cutter speeds at feed speeds of from 36 to 160 mm/min with water coolant.

8.3.1.2 Embedded thermocouples have been used to determine the temperature rise in the material near the apex of the notch during machining. Thermal stresses induced during the notching operation have been observed in transparent materials by viewing the specimen at low magnification between crossed

⁵ Supporting data is available from ASTM Headquarters. Request Research Report RR: D20-1066.