



SLOVENSKI STANDARD
SIST EN 1870-16:2005+A1:2009
01-december-2009

Varnost lesnoobdelovalnih strojev - Krožne žage - 16. del: Dvojne zajeralne žage za V-rezanje

Safety of woodworking machines - Circular sawing machines - Part 16: Double mitre sawing machines for V-cutting

Sicherheit von Holzbearbeitungsmaschinen - Kreissägemaschinen - Teil 16: Klinkschnittkreissägemaschinen

Sécurité des machines pour le travail du bois - Machines à scier circulaires - Partie 16: Tronçonneuses doubles à coupe en V

<https://standards.iteh.ai/catalog/standards/sist/2042c791-7950-4f06-88a5-fba4941b854c/sist-en-1870-16-2005a1-2009>

Ta slovenski standard je istoveten z: EN 1870-16:2005+A1:2009

ICS:

25.080.60	Strojne žage	Sawing machines
79.120.10	Lesnoobdelovalni stroji	Woodworking machines

SIST EN 1870-16:2005+A1:2009 **en,fr**

iTeh STANDARD PREVIEW
(standards.iteh.ai)

SIST EN 1870-16:2005+A1:2009

<https://standards.iteh.ai/catalog/standards/sist/2042c791-7950-4f06-88a5-fba4941b854c/sist-en-1870-16-2005a1-2009>

EUROPEAN STANDARD
NORME EUROPÉENNE
EUROPÄISCHE NORM

EN 1870-16:2005+A1

October 2009

ICS 79.120.10

Supersedes EN 1870-16:2005

English Version

Safety of woodworking machines - Circular sawing machines - Part 16: Double mitre sawing machines for V-cutting

Sécurité des machines pour le travail du bois - Machines à
scier circulaires - Partie 16: Tronçonneuses doubles à
coupe en V

Sicherheit von Holzbearbeitungsmaschinen -
Kreissägemaschinen - Teil 16:
Klinschnittkreissägemaschinen

This European Standard was approved by CEN on 21 February 2005 and includes Amendment 1 approved by CEN on 20 August 2009.

CEN members are bound to comply with the CEN/CENELEC Internal Regulations which stipulate the conditions for giving this European Standard the status of a national standard without any alteration. Up-to-date lists and bibliographical references concerning such national standards may be obtained on application to the CEN Management Centre or to any CEN member.

This European Standard exists in three official versions (English, French, German). A version in any other language made by translation under the responsibility of a CEN member into its own language and notified to the CEN Management Centre has the same status as the official versions.

CEN members are the national standards bodies of Austria, Belgium, Bulgaria, Cyprus, Czech Republic, Denmark, Estonia, Finland, France, Germany, Greece, Hungary, Iceland, Ireland, Italy, Latvia, Lithuania, Luxembourg, Malta, Netherlands, Norway, Poland, Portugal, Romania, Slovakia, Slovenia, Spain, Sweden, Switzerland and United Kingdom.

[SIST EN 1870-16:2005+A1:2009](https://standards.iteh.ai/catalog/standards/sist/2042c791-7950-4f06-88a5-fba4941b854c/sist-en-1870-16-2005a1-2009)

<https://standards.iteh.ai/catalog/standards/sist/2042c791-7950-4f06-88a5-fba4941b854c/sist-en-1870-16-2005a1-2009>



EUROPEAN COMMITTEE FOR STANDARDIZATION
COMITÉ EUROPÉEN DE NORMALISATION
EUROPÄISCHES KOMITEE FÜR NORMUNG

Management Centre: Avenue Marnix 17, B-1000 Brussels

Contents

Page

Foreword.....	4
Introduction	6
1 Scope	7
2 Normative references	8
3 Terms and definitions	10
3.1 General.....	10
3.2 Terms	10
3.3 Definitions	12
4 List of significant hazards	15
5 Safety requirements and/or measures	18
5.1 General.....	18
5.2 Controls	19
5.2.1 Safety and reliability of control systems.....	19
5.2.2 Position of controls	22
5.2.3 Starting	24
5.2.4 Normal stopping	24
5.2.5 Emergency stop.....	26
5.2.6 Mode selection	26
5.2.7 Failure of the power supply	26
5.2.8 Failure of the control circuits	26
5.3 Protection against mechanical hazards	27
5.3.1 Stability	27
5.3.2 Hazards of break-up during operation	27
5.3.3 Tool holder and tool design.....	28
5.3.4 Braking.....	29
5.3.5 Devices to minimise the possibility or the effect of ejection	30
5.3.6 Workpiece supports and guides	31
5.3.7 Prevention of access to moving parts.....	31
5.3.8 Workpiece clamping devices.....	36
5.4 Protection against non-mechanical hazards	37
5.4.1 Fire	37
5.4.2 Noise	37
5.4.3 Emission of chips, dust and gases.....	38
5.4.4 Electricity	39
5.4.5 Ergonomics and handling.....	39
5.4.6 Pneumatics.....	40
5.4.7 Electromagnetic compatibility.....	40
5.4.8 Errors of fitting.....	40
5.4.9 Supply disconnection (Isolation)	40
5.4.10 Maintenance	41
6 Information for use	41
6.1 General.....	41
6.2 Marking	41
6.3 Instruction handbook	42
Annex A (normative) Saw spindle dimensional tolerances	46
Annex ZA (informative) Relationship between this European Standard and the Essential Requirements of EU Directive 98/37	48

Annex ZB (informative) ⌘ Relationship between this European Standard and the Essential Requirements of EU Directive 2006/42/EC ⌘	51
Bibliography	55

iTeh STANDARD PREVIEW **(standards.iteh.ai)**

SIST EN 1870-16:2005+A1:2009

<https://standards.iteh.ai/catalog/standards/sist/2042c791-7950-4f06-88a5-fba4941b854c/sist-en-1870-16-2005a1-2009>

EN 1870-16:2005+A1:2009 (E)

Foreword

This document (EN 1870-16:2005+A1:2009) has been prepared by Technical Committee CEN/TC 142 "Woodworking machines - Safety", the secretariat of which is held by UNI.

This European Standard shall be given the status of a national standard, either by publication of an identical text or by endorsement, at the latest by April 2010, and conflicting national standards shall be withdrawn at the latest by April 2010.

Attention is drawn to the possibility that some of the elements of this document may be the subject of patent rights. CEN [and/or CENELEC] shall not be held responsible for identifying any or all such patent rights.

This document includes Amendment 1, approved by CEN on 2009-08-20.

This document supersedes EN 1870-16:2005.

The start and finish of text introduced or altered by amendment is indicated in the text by tags \square_{A1} \square_{A1} .

This document has been prepared under a mandate given to CEN by the European Commission and the European Free Trade Association, and supports essential requirements of \square_{A1} Machinery Directives \square_{A1} .

\square_{A1} For relationship with EU Directive(s), see informative Annexes ZA and ZB, which are integral parts of this document. \square_{A1}

STANDARD PREVIEW
(standards.iteh.ai)

\square_{A1} EN 1870 *Safety of woodworking machines — Circular sawing machines* consists of the following parts:

Part 1: Circular saw benches (with and without sliding table), dimension saws and building site saws

Part 3: Down cutting cross-cut saws and dual purpose down cutting cross-cut saws/circular saw benches

Part 4: Multi-blade rip sawing machines with manual loading and/or unloading

Part 5: Circular saw -benches/up-cutting cross-cut sawing machines

Part 6: Circular sawing machines for firewood and dual purpose circular sawing machines for firewood/circular saw benches, with manual loading and/or unloading

Part 7: Single blade log sawing machines with integrated feed table and manual loading and/or unloading

Part 8: Single blade edging circular rip sawing machines with power driven saw unit and manual loading and/or unloading

Part 9: Double blade circular sawing machines for cross-cutting with integrated feed and with manual loading and/or unloading

Part 10: Single blade automatic and semi-automatic up-cutting cross-cut sawing machines

Part 11: Semi-automatic and automatic horizontal cross-cut sawing machines with one saw unit (radial arm saws)

Part 12: Pendulum cross-cut sawing machines

Part 13: Horizontal beam panel sawing machines

Part 14: Vertical panel sawing machines

Part 15: Multi-blade cross-cut sawing machines with integrated feed of the workpiece and manual loading and/or unloading

Part 16: Double mitre sawing machines for V-cutting

Part 17: Manual horizontal cutting cross-cut sawing machines with one saw unit (manual radial arm saws) 

Organisations contributing to the preparation of this document include European Committee of Woodworking Machinery Manufacturers Association "EUMABOIS".

The documents produced by CEN/TC 142 are particular to woodworking machines and complement the relevant A and B standards on the subject of general safety (see introduction of EN ISO 12100-1:2003 for a description of A, B and C standards).

According to the CEN/CENELEC Internal Regulations, the national standards organizations of the following countries are bound to implement this European Standard: Austria, Belgium, Bulgaria, Cyprus, Czech Republic, Denmark, Estonia, Finland, France, Germany, Greece, Hungary, Iceland, Ireland, Italy, Latvia, Lithuania, Luxembourg, Malta, Netherlands, Norway, Poland, Portugal, Romania, Slovakia, Slovenia, Spain, Sweden, Switzerland and United Kingdom.

iTeh STANDARD PREVIEW **(standards.iteh.ai)**

[SIST EN 1870-16:2005+A1:2009](https://standards.iteh.ai/catalog/standards/sist/2042c791-7950-4f06-88a5-fba4941b854c/sist-en-1870-16-2005a1-2009)

<https://standards.iteh.ai/catalog/standards/sist/2042c791-7950-4f06-88a5-fba4941b854c/sist-en-1870-16-2005a1-2009>

EN 1870-16:2005+A1:2009 (E)**Introduction**

This document has been prepared to be a harmonised standard to provide one means of conforming to the essential safety requirements of the Machinery Directive, and associated EFTA regulations.

This document is a type C standard as stated in EN ISO 12100-1:2003.

The machinery concerned and the extent to which hazards, hazardous situations and events are covered are indicated in the scope of this document.

When provisions of this type C standard are different from those which are stated in type A or B standards, the provisions of this C type standard take precedence over the provisions of other standards, for machines that have been designed and built in accordance with the requirements of the provisions of this type C standard.

The requirements of this document are directed to manufacturers and their authorised representatives of double mitre sawing machines for V-cutting. They are also useful for designers.

This document also includes information to be provided by the manufacturer to the user.

Common requirements for tooling are given in EN 847-1:2005.

iTeh STANDARD PREVIEW
(standards.iteh.ai)

[SIST EN 1870-16:2005+A1:2009](https://standards.iteh.ai/catalog/standards/sist/2042c791-7950-4f06-88a5-fba4941b854c/sist-en-1870-16-2005a1-2009)

<https://standards.iteh.ai/catalog/standards/sist/2042c791-7950-4f06-88a5-fba4941b854c/sist-en-1870-16-2005a1-2009>

1 Scope

This document **A1** specifies all **A1** significant hazards, hazardous situations and events which are relevant to double mitre sawing machines for V-cutting with a maximum cutting capacity (width and height) of ≤ 200 mm, fitted or not with pneumatic systems, hereinafter referred to as the machine, designed to cut solid wood, chipboard, fibreboard or plywood and also these materials where they are covered with plastic laminate or edgings, when they are used as intended and under the conditions foreseen by the manufacturer (see Clause 4).

The requirements of this document apply to stationary and displaceable double mitre saw for V-cutting (see 3.3.3 and 3.3.4).

This document does not apply to transportable mitre saws or any adaptation permitting their use in a different mode, i.e. bench mounting.

NOTE 1 Transportable motor-operated electric single blade mitre saws are covered by the requirements of EN 61029-1:1996 and EN 61029-2-9:2002.

This document is not applicable to double mitre sawing machines for V-cutting fitted with hydraulic system.

This document is not applicable to double mitre sawing machines for V-cutting which are manufactured before the date of publication of this document by CEN.

NOTE 2 Machines covered by this document are listed under A.1.4 of Annex IV of the Machinery Directive.

iteh STANDARD PREVIEW
(standards.iteh.ai)

[SIST EN 1870-16:2005+A1:2009](https://standards.iteh.ai/catalog/standards/sist/2042c791-7950-4f06-88a5-fba4941b854c/sist-en-1870-16-2005a1-2009)

<https://standards.iteh.ai/catalog/standards/sist/2042c791-7950-4f06-88a5-fba4941b854c/sist-en-1870-16-2005a1-2009>



EN 1870-16:2005+A1:2009 (E)

2 Normative references

The following referenced documents are indispensable for the application of this document. For dated references, only the edition cited applies. For undated references, the latest edition of the referenced document (including any amendments) applies.

 deleted text 

EN 574:1996, *Safety of machinery — Two-hand control devices — Functional aspects — Principles for design*

 EN 614-1:2006, *Safety of machinery — Ergonomic design principles — Part 1: Terminology and general principles* 

EN 847-1:2005, *Tools for woodworking — Safety requirements — Part 1: Milling tools, circular saw blades*

 EN 894-1:1997, *Safety of machinery — Ergonomics requirements for the design of displays and control actuators — Part 1: General principles for human interactions with displays and control actuators*

EN 894-2:1997, *Safety of machinery — Ergonomics requirements for the design of displays and control actuators — Part 2: Displays*

EN 894-3:2000, *Safety of machinery — Ergonomics requirements for the design of displays and control actuators — Part 3: Control actuators* 

 deleted text 

iTeh STANDARD PREVIEW
(standards.iteh.ai)

EN 983:1996, *Safety of machinery — Safety requirements for fluid power systems and their components — Pneumatics*

 EN 1005-1:2001, *Safety of machinery — Human physical performance — Part 1: Terms and definitions*

EN 1005-2:2003, *Safety of machinery — Human physical performance — Part 2: Manual handling of machinery and component parts of machinery*

EN 1005-3:2002, *Safety of machinery — Human physical performance — Part 3: Recommended force limits for machinery operation*

EN 1005-4:2005, *Safety of machinery — Human physical performance — Part 4: Evaluation of working postures and movements in relation to machinery*

EN 1037:1995, *Safety of machinery — Prevention of unexpected start-up* 

EN 1088:1995, *Safety of machinery — Interlocking devices associated with guards — Principles for design and selection*

EN 1760-1:1997, *Safety of machinery — Pressure sensitive protective devices — Part 1: General principles for the design and testing of pressure sensitive mats and pressure sensitive floors*

EN 1760-2:2001, *Safety of machinery — Pressure sensitive protection devices — Part 2: General principles for the design and testing of pressure sensitive edges and pressure sensitive bars*

EN 50178:1997, *Electronic equipment for use in power installations*

 EN 50370-1:2005, *Electromagnetic compatibility (EMC) — Product family standard for machine-tools — Part 1: Emission*

EN 50370-2:2003, *Electromagnetic compatibility (EMC) — Product family standard for machine-tools — Part 2: Immunity* ^(A1)

^(A1) EN 60204-1:2006 ^(A1), *Safety of machinery — Electrical equipment of machines — Part 1: General requirements* ^(A1) (IEC 60204-1:2005, modified) ^(A1)

^(A1) EN 60439-1:1999, *Low-voltage switchgear and controlgear assemblies — Part 1: Type-tested and partially type-tested assemblies* (IEC 60439-1:1999) ^(A1)

EN 60529:1991, *Degrees of protection provided by enclosures (IP code)* (IEC 60529:1989)

^(A1) EN 60947-4-1:2001 ^(A1), *Low voltage switchgear and control gear — Part 4-1: Contactors and motor starters — Electromechanical contactors and motor starters* ^(A1) (IEC 60947-4-1:2000) ^(A1)

EN 60947-5-1:2004, *Low voltage switchgear and controlgear — Part 5-1: Control circuit devices and switching elements — Electromechanical control circuit devices* (IEC 60947-5-1:2003)

^(A1) EN 61310-1:2008, *Safety of machinery — Indication, marking and actuation — Part 1: Requirements for visual, auditory and tactile signals* (IEC 61310-1:2007) ^(A1)

EN 61496-1:2004, *Safety of machinery — Electro-sensitive protective equipment — Part 1: General requirements and tests* (IEC 61496-1:2004, modified)

^(A1) CLC/TS 61496-2:2006 ^(A1), *Safety of machinery — Electro-sensitive protective equipment — Part 2: Particular requirements for equipment using active opto-electronic protective devices (AOPDs)* (IEC 61496-2:2006) ^(A1)

EN 61508-3:2001, *Functional safety of electrical/electronic/programmable electronic safety-related systems — Part 3: Software requirements* (IEC 61508-3:1998 + Corrigendum:1999)

^(A1) EN 62061:2005 ^(A1), *Safety of machinery — functional safety of safety-related electrical, electronic and programmable electronic control systems* ^(A1) (IEC 62061:2005) ^(A1)

EN ISO 3743-1:1995, *Acoustics — Determination of sound power levels of noise sources — Engineering methods for small, movable sources in reverberant fields — Part 1: Comparison method for hard-walled test rooms* (ISO 3743-1:1994)

EN ISO 3743-2:1996, *Acoustics — Determination of sound power levels of noise sources using sound pressure — Engineering methods for small, movable sources in reverberant fields — Part 2: Methods for special reverberation test rooms* (ISO 3743-2:1994)

EN ISO 3744:1995, *Acoustics — Determination of sound power levels of noise sources using sound pressure — Engineering method in an essentially free field over a reflecting plane* (ISO 3744:1994)

EN ISO 3745:2003, *Acoustics — Determination of sound power levels of noise sources using sound pressure — Precision methods for anechoic and semi-anechoic rooms* (ISO 3745:2003)

EN ISO 3746:1995, *Acoustics — Determination of sound power levels of noise sources using sound pressure — Survey method using an enveloping measurement surface over a reflecting plane* (ISO 3746:1995)

EN ISO 4871:1996, *Acoustics — Declaration and verification of noise emission values of machinery and equipment* (ISO 4871:1996)

EN ISO 9614-1:1995, *Acoustics — Determination of sound power levels of noise sources using sound intensity — Part 1: Measurement at discrete points* (ISO 9614-1:1993)

EN ISO 11202:1995, *Acoustics — Noise emitted by machinery and equipment — Measurement of emission sound pressure levels at the work station and at other specified positions — Survey method in situ* (ISO 11202:1995)

EN 1870-16:2005+A1:2009 (E)

EN ISO 11204:1995, *Acoustics — Noise emitted by machinery and equipment — Measurement of emission sound pressure levels at a work station and at other specified positions — Method requiring environmental corrections (ISO 11204:1995)*

EN ISO 11688-1:1998, *Acoustics — Recommended practice for the design of low-noise machinery and equipment — Part 1: Planning (ISO/TR 11688-1:1995)*

EN ISO 11688-2:2000, *Acoustics — Recommended practice for the design of low-noise machinery and equipment — Part 2: Introduction to the physics of low-noise design (ISO TR 11688-2:1998)*

EN ISO 12100-1:2003 *Safety of machinery — Basic concepts, general principles for design — Part 1: Basic terminology, methodology (ISO 12100-1:2003)*

EN ISO 12100-2:2003 *Safety of machinery — Basic concepts, general principles for design — Part 2: Technical principles (ISO 12100-2:2003)*

Ⓐ₁ deleted text Ⓐ₁

Ⓐ₁ EN ISO 13849-1:2008, *Safety of machinery — Safety-related parts of control systems — Part 1: General principles for design (ISO 13849-1:2006)* Ⓐ₁

Ⓐ₁ EN ISO 13849-2:2008 Ⓐ₁, *Safety of machinery — Safety-related parts of control systems — Part 2: Validation (ISO 13849-2:2003)*

Ⓐ₁ EN ISO 13850:2006, *Safety of machinery — Emergency stop — Principles for design (ISO 13850:2006)* Ⓐ₁

Ⓐ₁ EN ISO 13857:2008, *Safety of machinery — Safety distances to prevent hazard zones being reached by upper and lower limbs (ISO 13857:2008)* Ⓐ₁

ISO 7960, *Airborne noise emitted by machine tools — Operating conditions for woodworking machines*

Ⓐ₁ HD 21.1 S4:2002, *Cables of rated voltages up to and including 450/750 V and having thermoplastic insulation — Part 1: General requirements* Ⓐ₁

Ⓐ₁ HD 22.1 S4:2002, *Cables of rated voltages up to and including 450/750 V and having cross-linked insulation — Part 1: General requirements* Ⓐ₁

3 Terms and definitions

3.1 General

For the purposes of this document, the terms and definitions given in EN ISO 12100-1:2003 and the following apply.

3.2 Terms

The main parts of vertical and horizontal double mitre sawing machines for V-cutting and their terminology are illustrated in Figures 1 and 2.

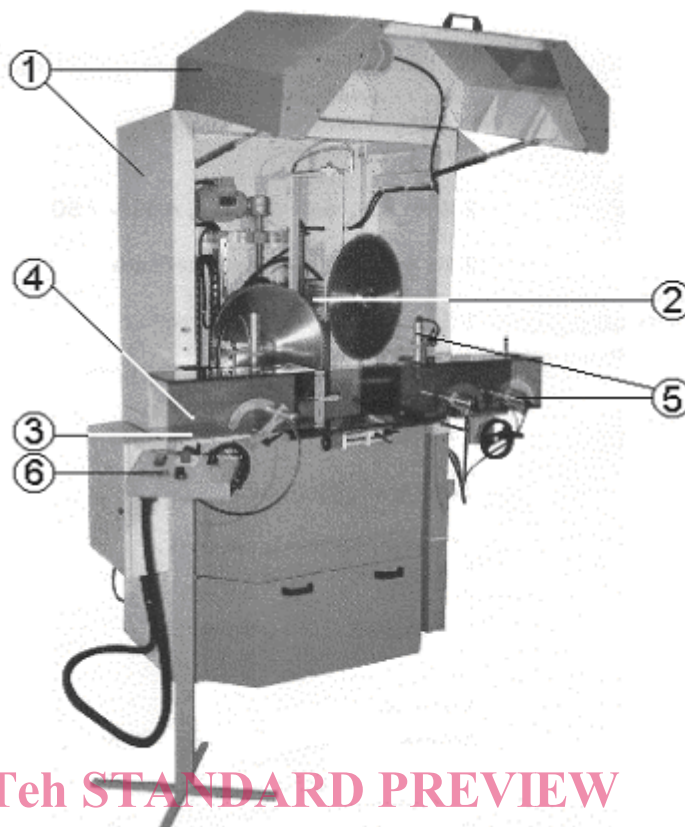

iTeh STANDARD PREVIEW
(standards.iteh.ai)

Key

- 1 Enclosure
- 2 Saw unit
- 3 Machine table
- 4 Fence
- 5 Workpiece clamping devices
- 6 Controls

[SIST EN 1870-16:2005+A1:2009](https://standards.iteh.ai/catalog/standards/sist/2042c791-7950-4f06-88a5-fba4941b854c/sist-en-1870-16-2005a1-2009)
<https://standards.iteh.ai/catalog/standards/sist/2042c791-7950-4f06-88a5-fba4941b854c/sist-en-1870-16-2005a1-2009>

Figure 1 — Terminology of a vertical double mitre sawing machine for V-cutting

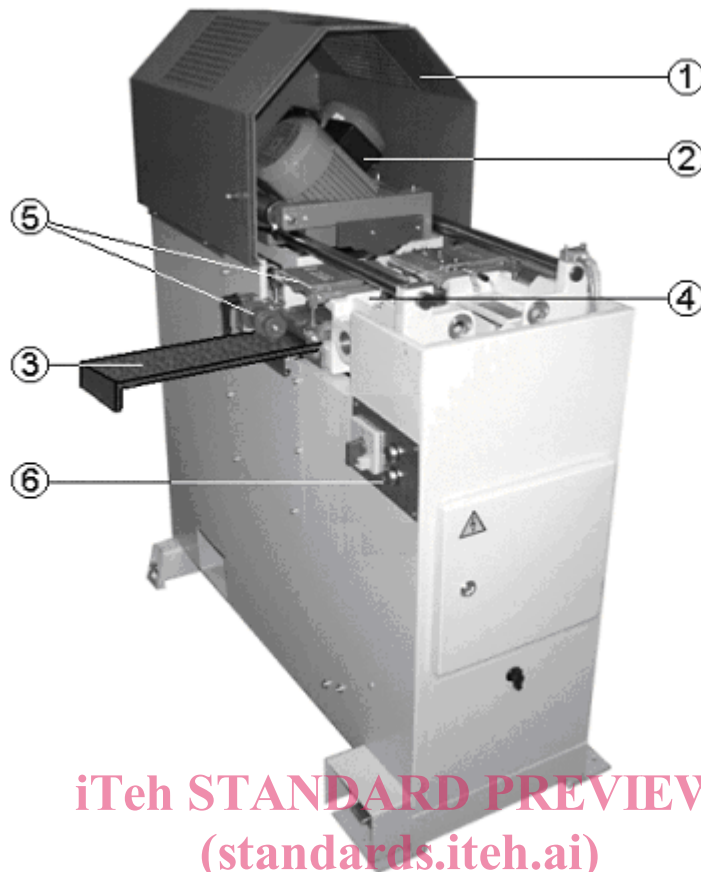

iTeh STANDARD PREVIEW
(standards.iteh.ai)

[SIST EN 1870-16:2005+A1:2009](https://standards.iteh.ai/catalog/standards/sist/2042c791-7950-4f06-88a5-fba4941b854c/sist-en-1870-16-2005a1-2009)

<https://standards.iteh.ai/catalog/standards/sist/2042c791-7950-4f06-88a5-fba4941b854c/sist-en-1870-16-2005a1-2009>

Key

- | | |
|---|----------------------------|
| 1 | Enclosure |
| 2 | Saw unit |
| 3 | Machine table |
| 4 | Fence |
| 5 | Workpiece clamping devices |
| 6 | Controls |

Figure 2 — Terminology of a horizontal double mitre sawing machine for V-cutting

3.3 Definitions

3.3.1

cross-cutting

operation of cutting across the grain of a wooden workpiece

3.3.2

double mitre sawing machine for V-cutting

machine designed to make special cross-cuts for e.g. picture frames, furniture, doors or furnishings. The machine is fitted with one saw unit or two saw units (dual stroke machine). The saw unit consists of one or two saw blades whose spindles are situated above (vertical double mitre sawing machine for V-cutting, see Figure 1) or behind the workpiece (horizontal double mitre sawing machine for V-cutting, see Figure 2) when the saw blades are in their rest positions. The angle between the saw spindle axes can be either fixed (normally 45°) or adjustable from 0° to 45° with respect to the centre line of the machine. The saw blades move into or through the workpiece in vertical or horizontal direction during the cut to produce a V-cut in one cycle. The feed of the saw unit can be manual or integrated feed

3.3.2.1**manual double mitre sawing machine for V-cutting**

machine where the saw unit is fed by hand and the workpiece is manually positioned for V-cutting

NOTE This type of machine is not covered by Annex IV of the Machinery Directive.

3.3.2.2**dual stroke double mitre sawing machine for V-cutting**

machine fitted with two saw units which are situated in their rest position above (dual stroke vertical double mitre sawing machine for V-cutting) or behind the workpiece (dual stroke horizontal double mitre sawing machine for V-cutting). Each of the saw units can be moved independently. The workpiece is manually positioned for V-cutting

NOTE This type of machine is not covered by Annex IV of the Machinery Directive.

3.3.2.3**semi-automatic double mitre sawing machine for V-cutting**

machine where the saw unit has an integrated feed which is initiated manually and the workpiece is positioned manually for V-cutting

NOTE This type of machine is covered by Annex IV of the Machinery Directive.

3.3.2.4**automatic double mitre sawing machine for V-cutting**

machine where the saw unit has an integrated feed. The workpiece may be manually loaded and/or unloaded and is automatically positioned for V-cutting to pre-selected lengths

NOTE This type of machine is covered by Annex IV of the Machinery Directive if the workpiece is manually loaded and/or unloaded.

3.3.3

stationary machine machine designed to be located on or fixed to the floor or other parts of the structure of the premises and to be stationary during use

3.3.4**displaceable machine**

machine which is located on the floor, stationary during use and equipped with a device, e.g. wheels, which allows it to be moved between locations

3.3.5**hand feed**

manual holding and/or guiding of the workpiece and/or of the saw unit

3.3.6**integrated feed**

feed mechanism for the workpiece or tool which is integrated with the machine and where the workpiece or machine element with incorporated tool are held and controlled mechanically during the machining operation

3.3.7**manual loading of power fed machines**

operation where the workpiece is presented by the operator directly to the machine integrated feed, e.g. rotating feed rollers, travelling table or reciprocating carriage; i.e. for which there is no intermediate loading device to receive and transfer the workpiece from the operator to the integrated feed