



SLOVENSKI STANDARD
SIST EN ISO 17641-2:2005

01-november-2005

Dcfi ý]h Yb]dfYg_i g]nj Ufcj `bU_cj]bg_`a UHf]U`È`DfYg_i g]`bUdc_Ub`Y`j
j fc Ya `nU`nj UfbY`gdc`Y`È`CV`c b]`bU]b]`j Uf`Yb`UÈ`&`XY.`DfYg_i g]`dc_`]j`cg]`bU
dfcgh`j`dYH`a `dfYg_i ýUbW`f`GC`%`*`(`%&`&\$`\$) Ł

Destructive tests on welds in metallic materials - Hot cracking tests for weldments - Arc welding processes - Part 2: Self-restraint tests (ISO 17641-2:2005)

iTeh STANDARD PREVIEW

Zerstörende Prüfung von Schweißverbindungen an metallischen Werkstoffen - Heißrissprüfungen für Schweißungen - Lichtbogenschweißprozesse - Teil 2: Selbstbeanspruchende Prüfungen (ISO 17641-2:2005)

<https://standards.iteh.ai/catalog/standards/sist/3c030f66-af71-4cc0-b06f-91ee1c665868/sist-en-iso-17641-2-2005>

Essais destructifs des soudures sur matériaux métalliques - Essais de fissuration a chaud des assemblages soudés - Procédés de soudage a l'arc - Partie 2: Essais sur éprouvettes auto-bridées (ISO 17641-2:2005)

Ta slovenski standard je istoveten z: EN ISO 17641-2:2005

ICS:

25.160.40 Varjeni spoji in vari Welded joints

SIST EN ISO 17641-2:2005 en

iTeh STANDARD PREVIEW
(standards.iteh.ai)

[SIST EN ISO 17641-2:2005](#)

<https://standards.iteh.ai/catalog/standards/sist/3c030fc6-af71-4cc0-b06f-91ee1c665868/sist-en-iso-17641-2-2005>

EUROPEAN STANDARD
NORME EUROPÉENNE
EUROPÄISCHE NORM

EN ISO 17641-2

March 2005

ICS 25.160.40

English version

Destructive tests on welds in metallic materials - Hot cracking tests for weldments - Arc welding processes - Part 2: Self-restraint tests (ISO 17641-2:2005)

Essais destructifs des soudures sur matériaux métalliques -
Essais de fissuration à chaud des assemblages soudés -
Procédés de soudage à l'arc - Partie 2: Essais sur
éprouvettes auto-bridées (ISO 17641-2:2005)

Zerstörende Prüfung von Schweißverbindungen an
metallischen Werkstoffen - Heißrissprüfungen für
Schweißungen - Lichtbogenschweißprozesse - Teil 2:
Selbstbeanspruchende Prüfungen (ISO 17641-2:2005)

This European Standard was approved by CEN on 9 February 2004.

CEN members are bound to comply with the CEN/CENELEC Internal Regulations which stipulate the conditions for giving this European Standard the status of a national standard without any alteration. Up-to-date lists and bibliographical references concerning such national standards may be obtained on application to the Central Secretariat or to any CEN member.

This European Standard exists in three official versions (English, French, German). A version in any other language made by translation under the responsibility of a CEN member into its own language and notified to the Central Secretariat has the same status as the official versions.

CEN members are the national standards bodies of Austria, Belgium, Cyprus, Czech Republic, Denmark, Estonia, Finland, France, Germany, Greece, Hungary, Iceland, Ireland, Italy, Latvia, Lithuania, Luxembourg, Malta, Netherlands, Norway, Poland, Portugal, Slovakia, Slovenia, Spain, Sweden, Switzerland and United Kingdom.



EUROPEAN COMMITTEE FOR STANDARDIZATION
COMITÉ EUROPÉEN DE NORMALISATION
EUROPÄISCHES KOMITEE FÜR NORMUNG

Management Centre: rue de Stassart, 36 B-1050 Brussels

Contents

	page
Foreword.....	3
1 Scope	4
2 Normative references	4
3 Terms and definitions	4
4 Symbols, designations and units.....	4
5 Principle.....	5
6 Description of the tests.....	6
6.1 T-joint weld cracking tests.....	6
6.1.1 General.....	6
6.1.2 Dimension of the test pieces	6
6.1.3 Preparation of the test pieces	8
6.1.4 Welding of the test pieces	9
6.1.5 Examination of the test piece	9
6.1.6 Test report	9
6.2 Weld metal tensile test.....	9
6.2.1 General.....	9
6.2.2 Test specimen	9
6.2.3 Examination of the test specimen.....	10
6.2.4 Test report	11
6.3 Longitudinal bend test	11
6.3.1 General.....	11
6.3.2 Test weld.....	11
6.3.3 Test specimen	11
6.3.4 Surface preparation	13
6.3.5 Testing	13
6.3.6 Examination of the test specimen.....	13
6.3.7 Test report	13
Annex A (informative) Test report for T-joint weld cracking test	14
Annex B (informative) Test report for weld metal tensile test	15
Annex C (informative) Test report for longitudinal bend test	16
Annex ZA (normative) List of corresponding European and International Standards for which equivalents are not given in the text.....	17

Foreword

This document (EN ISO 17641-2:2005) has been prepared by Technical Committee CEN/TC 121 “Welding”, the secretariat of which is held by DIN, in collaboration with Technical Committee ISO/TC 44 “Welding and allied processes”.

This European Standard shall be given the status of a national standard, either by publication of an identical text or by endorsement, at the latest by September 2005, and conflicting national standards shall be withdrawn at the latest by September 2005.

EN ISO 17641 consists of the following parts, under the general title *Destructive tests on welds in metallic materials – Hot cracking tests for weldments – Arc welding processes*:

- Part 1: General
- Part 2: Self-restraint tests
- Part 3: Externally loaded tests¹

According to the CEN/CENELEC Internal Regulations, the national standards organizations of the following countries are bound to implement this European Standard: Austria, Belgium, Cyprus, Czech Republic, Denmark, Estonia, Finland, France, Germany, Greece, Hungary, Iceland, Ireland, Italy, Latvia, Lithuania, Luxembourg, Malta, Netherlands, Norway, Poland, Portugal, Slovakia, Slovenia, Spain, Sweden, Switzerland and United Kingdom.

(standards.iteh.ai)

[SIST EN ISO 17641-2:2005](https://standards.iteh.ai/catalog/standards/sist/3c030fc6-af71-4cc0-b06f-91ee1c665868/sist-en-iso-17641-2-2005)

<https://standards.iteh.ai/catalog/standards/sist/3c030fc6-af71-4cc0-b06f-91ee1c665868/sist-en-iso-17641-2-2005>

¹ Part 3 will be published as a Technical Report with the same general title.

EN ISO 17641-2:2005 (E)**1 Scope**

This standard specifies the required specimens, the test piece dimensions and the procedures to be followed to carry out self-restraint hot cracking tests.

The following tests are described:

- T-joint weld cracking test
- Weld metal tensile test
- Longitudinal bend test

The tests are designed to provide information about the hot cracking sensitivity of weld metals. The tests are not suitable for the assessment of parent materials.

The standard applies primarily to fully austenitic stainless steels; nickel, nickel base and nickel copper weld metals. The standard can also be used for other weld metals.

This standard describes only how to carry out the tests and report the results. It does not give any acceptance criteria.

iTeh STANDARD PREVIEW
(standards.iteh.ai)

2 Normative references

The following referenced documents are indispensable for the application of this document. For dated references, only the edition cited applies. For undated references, the latest edition of the referenced document (including any amendments) applies.

EN 876, *Destructive tests on welds in metallic materials - Longitudinal tensile test on weld metal in fusion welded joints*

EN 910, *Destructive tests on welds in metallic materials - Bend tests*

EN 1597-1, *Welding consumables - Test methods - Part 1: Test piece for all-weld metal test specimens in steel, nickel and nickel alloys*

EN 10002-1, *Metallic materials - Tensile testing - Part 1: Method of test at ambient temperature*

EN ISO 15614-1, *Specification and qualification of welding procedures for metallic materials - Welding procedure test - Part 1: Arc and gas welding of steels and arc welding of nickel and nickel alloys (ISO 15614-1:2004)*

EN ISO 17641-1:2004, *Destructive tests on welds in metallic materials - Hot cracking tests for weldments – Arc welding processes - Part 1: General (ISO 17641-1:2004)*

3 Terms and definitions

For the purposes of this document, the terms and definitions given in EN ISO 17641-1:2004 apply.

4 Symbols, designations and units

For the purposes of this European Standard, the symbols and units given in Table 1 apply.

Table 1 - Symbols, designations and units

Symbol	Designation	Unit
T-joint weld cracking test		
a_1	Throat thickness of weld bead 1	mm
a_2	Throat thickness of weld beat 2	mm
t_1	Thickness of vertical plate, form C	mm
t_2	Thickness of horizontal plate, form C	mm
Weld metal tensile test		
d	Specimen diameter	mm
L_c	Test length	mm
L_o	Measuring length on the test specimen	mm
L_e	Measuring length on the test specimen after fracture ^a	mm
L_t	Total length	mm
L_{MF}	Total crack length of all detected cracks > 0,1 mm	mm
l_1	Length of an individual crack	mm
$MSI_{(TT)}$	Microcracks Sensitivity Indicator (Tensile test) ^b	mm/mm ²
Longitudinal bend test (LBT)		
R	Radius of the test specimen edges >1	mm
B	Width of the test specimen	mm
b_1	Width of outside fusion line	mm
l_1	Length of an individual crack	mm
l_o	Length of crack examination area before bending	mm
L_{MF}	Total crack length of all detected cracks >0.1	mm
L_s	Maximum width of the weld after machining	mm
$MSI_{(LBT)}$	Microcrack Sensitivity Indicator (Longitudinal Bend Test) ^c	mm/mm ²
^a $X_1+X_2=L_e$, see Figure 4 ^b $MSI = L_{MF} / L_o \times d \times \pi$ ^c $MSI = L_{MF} / b \times l_o$		

5 Principle

Three test methods are described which are designed to measure the sensitivity of weld metals to the types of hot cracking described in clause 3. These test methods are described in Table 2.

In all cases the cracks are generated during the welding of the test pieces. The tensile test and longitudinal bend test are subjected to additional straining, which does not generate any new cracks, but widens the cracks formed during the welding, which enables them to be more easily detected and measured.

Table 2 - Self-restraint hot cracking tests and applications

Type of Test	Types of cracking	Results	Applications
T-joint weld cracking test	Solidification	Qualitative	Qualification of welding consumables Qualification test for welding consumables
Weld metal tensile tests	Solidification	Qualitative or quantitative if Microcrack Sensitivity Index $MSI_{(TT)}$ is used	Welding procedure qualification
	Liquation		Production weld coupon test
	Ductility dip		Qualification of consumables Qualification test for welding consumables
Longitudinal bend test	Solidification	Qualitative or quantitative if $MSI_{(LBT)}$ is used	Welding procedure qualification
	Liquation		Production weld coupon test
	Ductility dip		Qualification of welding consumables Qualification test for welding consumables

6 Description of the tests

ITeh STANDARD PREVIEW
(standards.iteh.ai)

6.1 T-joint weld cracking tests

6.1.1 General

<https://standards.iteh.ai/catalog/standards/sist/3c030fc6-af71-4cc0-b06f-91ee1c665868/sist-en-iso-17641-2-2005>

The test procedure applies to a single pass restrained fillet weld. It can be used with the manual shielded metal arc, gas metal arc and tungsten arc welding processes. It is not suitable for high current processes such as submerged arc.

The test method only provides a qualitative assessment (cracks or no cracks) and has a comparatively low sensitivity.

6.1.2 Dimension of the test pieces

Three types of test (A, B and C) are specified. Type A is the standard test piece. Types B and C are more highly restrained and are used to simulate more severe conditions.

The dimensions of the test pieces shall be as shown in Figure 1.

The test pieces shall be made from the parent material for which the consumable is designed (consumable approval test) or that which is to be used in a fabrication (procedure qualification test).

Type B requires the use of a 40 mm thick horizontal plate. If this is not available, then Type C, which uses 10 mm thick stiffeners welded on the horizontal plate, may be used. The thickness of the horizontal and vertical plate and/or the stiffeners can be modified.

Dimensions in millimetres

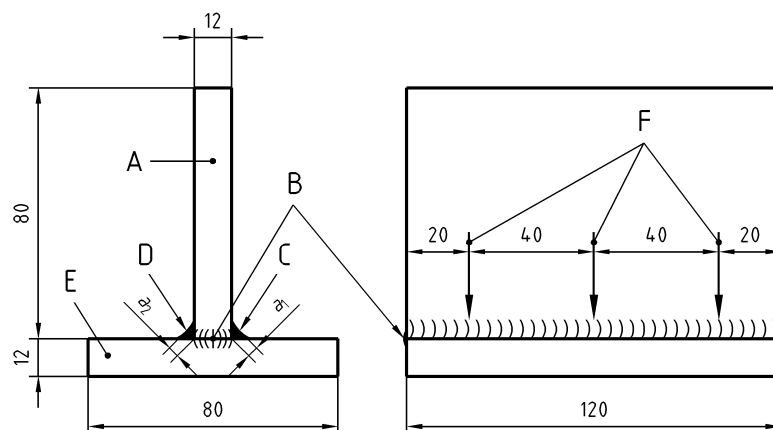
**Key**

- A Vertical plate
- B Tack welds
- C Weld bead 1
- D Weld bead 2
- E Horizontal plate
- F Measuring points

iTeh STANDARD PREVIEW
 Figure 1 a) Type A
 (standards.iteh.ai)

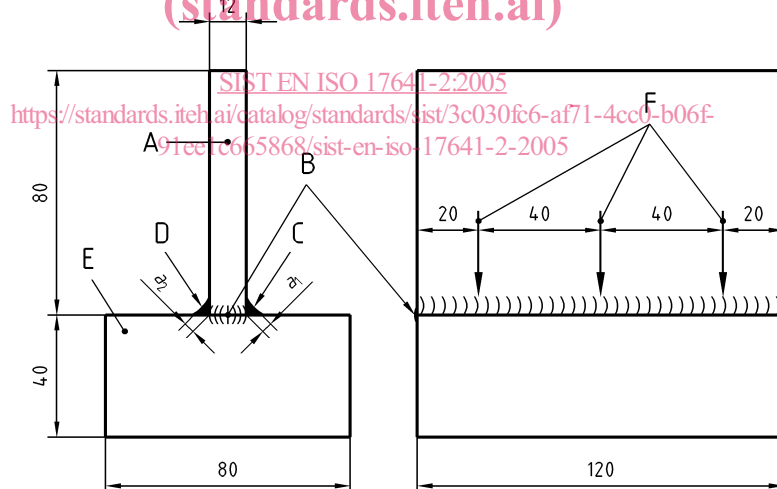
**Key**

- a Throat thickness (6 mm)
- A Vertical plane
- B Tack welds
- C Weld bead 1
- D Weld bead 2
- E Horizontal plate
- F Measuring points

Figure 1 b) Type B