



SLOVENSKI STANDARD
SIST EN 15182-1:2007+A1:2010
01-januar-2010

; Ug]g_]fc b_]!'%'XY.'Gd`cýbY`nU hYj Y

Hand-held branchpipes for fire service use - Part 1: Common requirements

Strahlrohre für die Brandbekämpfung - Teil 1: Allgemeine Anforderungen

Lances à main destinées aux services d'incendie et de secours - Partie 1: Prescriptions communes

(standards.iteh.ai)

Ta slovenski standard je istoveten z: EN 15182-1:2007+A1:2009

<https://standards.iteh.ai/catalog/standards/sist/e49d154e-5aa3-40a3-81f8-98c308c6404b/sist-en-15182-1-2007a1-2010>

ICS:

13.220.10 Gašenje požara Fire-fighting

SIST EN 15182-1:2007+A1:2010 **en,fr,de**

iTeh STANDARD PREVIEW
(standards.iteh.ai)

SIST EN 15182-1:2007+A1:2010

<https://standards.iteh.ai/catalog/standards/sist/e49d154e-5aa3-40a3-81f8-98c308c6404b/sist-en-15182-1-2007a1-2010>

EUROPEAN STANDARD
NORME EUROPÉENNE
EUROPÄISCHE NORM

EN 15182-1:2007+A1

November 2009

ICS 13.220.10

Supersedes EN 15182-1:2007

English Version

Hand-held branchpipes for fire service use - Part 1: Common requirements

Lances à main destinées aux services d'incendie et de secours - Partie 1: Prescriptions communes

Strahlrohre für die Brandbekämpfung - Teil 1: Allgemeine Anforderungen

This European Standard was approved by CEN on 23 December 2006 and includes Amendment 1 approved by CEN on 29 September 2009.

CEN members are bound to comply with the CEN/CENELEC Internal Regulations which stipulate the conditions for giving this European Standard the status of a national standard without any alteration. Up-to-date lists and bibliographical references concerning such national standards may be obtained on application to the CEN Management Centre or to any CEN member.

This European Standard exists in three official versions (English, French, German). A version in any other language made by translation under the responsibility of a CEN member into its own language and notified to the CEN Management Centre has the same status as the official versions.

CEN members are the national standards bodies of Austria, Belgium, Bulgaria, Cyprus, Czech Republic, Denmark, Estonia, Finland, France, Germany, Greece, Hungary, Iceland, Ireland, Italy, Latvia, Lithuania, Luxembourg, Malta, Netherlands, Norway, Poland, Portugal, Romania, Slovakia, Slovenia, Spain, Sweden, Switzerland and United Kingdom.

[SIST EN 15182-1:2007+A1:2010](https://standards.iteh.ai/catalog/standards/sist/e49d154e-5aa3-40a3-81f8-98c308c6404b/sist-en-15182-1-2007a1-2010)

<https://standards.iteh.ai/catalog/standards/sist/e49d154e-5aa3-40a3-81f8-98c308c6404b/sist-en-15182-1-2007a1-2010>



EUROPEAN COMMITTEE FOR STANDARDIZATION
COMITÉ EUROPÉEN DE NORMALISATION
EUROPÄISCHES KOMITEE FÜR NORMUNG

Management Centre: Avenue Marnix 17, B-1000 Brussels

Contents

	Page
Foreword.....	3
Introduction	4
1 Scope	5
2 Normative references	5
3 Terms and definitions	5
4 Description	6
5 Classification.....	8
6 Requirements	8
6.1 Mechanical characteristics	8
6.2 Materials	8
6.3 Flush	9
7 Testing and proofs.....	9
7.1 General.....	9
7.2 Heat and frost test	9
7.3 Drop tests	9
7.4 Flushing	12
8 Information for use	12
8.1 Instruction and maintenance handbook	12
8.2 Marking	12
Annex A (normative) Classification of branchpipes for fire service use	14
Annex B (informative) Acceptance test on delivery	15
Annex C (normative) Datasheet for hand-held branchpipes for fire service use	16
Annex D (informative) Example of completed datasheet for hand-held branchpipes for fire service use	22
Bibliography	30

iTech STANDARD PREVIEW
(standards.iteh.ai)

SIST EN 15182-1:2007+A1:2010

[https://standards.iteh.ai/catalog/standards/sist/e49d154e-5aa3-40a3-81f8-](https://standards.iteh.ai/catalog/standards/sist/e49d154e-5aa3-40a3-81f8-98c588c04070/sist-en-15182-1-2007-a1-2010)

[98c588c04070/sist-en-15182-1-2007-a1-2010](https://standards.iteh.ai/catalog/standards/sist/e49d154e-5aa3-40a3-81f8-98c588c04070/sist-en-15182-1-2007-a1-2010)

Foreword

This document (EN 15182-1:2007+A1:2009) has been prepared by Technical Committee CEN/TC 192 “Fire service equipment”, the secretariat of which is held by BSI.

This European Standard shall be given the status of a national standard, either by publication of an identical text or by endorsement, at the latest by May 2010, and conflicting national standards shall be withdrawn at the latest by May 2010.

Attention is drawn to the possibility that some of the elements of this document may be the subject of patent rights. CEN [and/or CENELEC] shall not be held responsible for identifying any or all such patent rights.

This document includes Amendment 1, approved by CEN on 2009-09-29.

This document supersedes EN 15182-1:2007.

The start and finish of text introduced or altered by amendment is indicated in the text by tags $\boxed{A1}$ $\boxed{A1}$.

EN 15182 consists of the following parts, under the general title *Hand-held branchpipes for fire service use*:

- *Part 1: Common requirements*;
- *Part 2: Combination branchpipes PN 16*;
- *Part 3: Smooth bore jet and/or one fixed spray jet angle branchpipes PN 16*;
- *Part 4: High pressure branchpipes PN 40*.

According to the CEN/CENELEC Internal Regulations, the national standards organizations of the following countries are bound to implement this European Standard: Austria, Belgium, Bulgaria, Cyprus, Czech Republic, Denmark, Estonia, Finland, France, Germany, Greece, Hungary, Iceland, Ireland, Italy, Latvia, Lithuania, Luxembourg, Malta, Netherlands, Norway, Poland, Portugal, Romania, Slovakia, Slovenia, Spain, Sweden, Switzerland and United Kingdom.

EN 15182-1:2007+A1:2009 (E)

Introduction

This European Standard has been created to provide a minimum level of safety and performance criteria.

Its purpose is not to define a specific branchpipe design but to help the user in understanding and choosing the correct equipment.

iTeh STANDARD PREVIEW (standards.iteh.ai)

SIST EN 15182-1:2007+A1:2010

<https://standards.iteh.ai/catalog/standards/sist/e49d154e-5aa3-40a3-81f8-98c308c6404b/sist-en-15182-1-2007a1-2010>

1 Scope

This part of this European Standard applies to hand-held branchpipes. It deals with:

- safety requirements;
- performance requirements;
- test methods;
- classification and designation;
- instructions for use and maintenance;
- marking.

This standard should be read in conjunction with parts 2, 3 or 4.

This standard does not apply to branchpipes covered by EN 671, foam branchpipes, powder branchpipes, or branchpipes with a maximum working pressure above 40 bar.

NOTE 1 The Working Group has thoroughly addressed and discussed the issue of electrical safety in relation to using water branchpipes. However, an electrical test is not incorporated into this standard as international experience, as well as research (NFPA handbook, French research, etc) have shown that any "artificial" or "laboratory style" testing will not take into account poor visibility and other conditions present on any fireground, nor the problem of estimating distances under these conditions. The end user should be advised (through the operating instructions, see 8.1) that when fighting fires in or near electrical installations, the power should be cut off as soon as possible. Also, maintain a maximum possible safety distance (at least 1 m up to 1 000 V) and use a spray jet with a minimum spray angle of 30°.

NOTE 2 Reaction forces should be taken into consideration before choosing and operating branchpipes.

2 Normative references

The following referenced documents are indispensable for the application of this document. For dated references, only the edition cited applies. For undated references, the latest edition of the referenced document (including any amendments) applies.

EN 15182-2, *Hand-held branchpipes for fire service use — Part 2: Combination branchpipes PN 16*

EN 15182-3, *Hand-held branchpipes for fire service use — Part 3: Smooth bore jet and/or one fixed spray jet angle branchpipes PN 16*

EN 15182-4, *Hand-held branchpipes for fire service use — Part 4: High pressure branchpipes PN 40*

3 Terms and definitions

For the purposes of this document, the following terms and definitions apply.

3.1

branchpipe

combination of components that connects to a water supply via a hose and coupling and projects water according to the operators requirements

3.2

nozzle

component of a branchpipe that controls the water flow rate and/or pattern

EN 15182-1:2007+A1:2009 (E)**3.3
pressures**

NOTE 1 Pressures expressed in bars are measured at the inlet of the branchpipe.

NOTE 2 1 bar = 0,1 MPa (10^5 Pa).

**3.3.1
reference pressure**

p_R
standard working pressure used to run hydraulic tests

**3.3.2
median pressure**

p_m
for type 4 branchpipes, average pressure of the pressure control range

NOTE Type 4 branchpipes are defined in EN 15182-2 and Annex A.

**3.3.3
nominal pressure**

p_N
maximum working pressure

**3.3.4
test pressure**

p_t
static pressure used for leakage tests

iTeh STANDARD PREVIEW
(standards.iteh.ai)

**3.3.5
burst pressure**

p_B
static pressure used for burst test

[SIST EN 15182-1:2007+A1:2010](https://standards.iteh.ai/catalog/standards/sist/e49d154e-5aa3-40a3-81f8-98c308c6404b/sist-en-15182-1-2007a1-2010)
<https://standards.iteh.ai/catalog/standards/sist/e49d154e-5aa3-40a3-81f8-98c308c6404b/sist-en-15182-1-2007a1-2010>

**3.4
jet****3.4.1
straight jet**

jet having the maximum throw and mechanical effect

**3.4.2
spray jet**

any jet different to the straight jet

**3.5
flush**

position allowing the branchpipe to clear debris

4 Description

A hand-held branchpipe is comprised of at least the following components (see Figure 1):

- fitting system;
- gripping device;
- open and shut-off device (e.g. operated by a valve handle, a lever or a trigger);

NOTE 1 An open and shut-off device can also be accommodated in a twist shut-off nozzle.

- one or more jet/spray system(s), if applicable;
- if applicable, a flow adjustment system (e.g. operated by a valve handle, a rotating operating element or a trigger).

NOTE 2 These components may consist of a single piece or several parts.

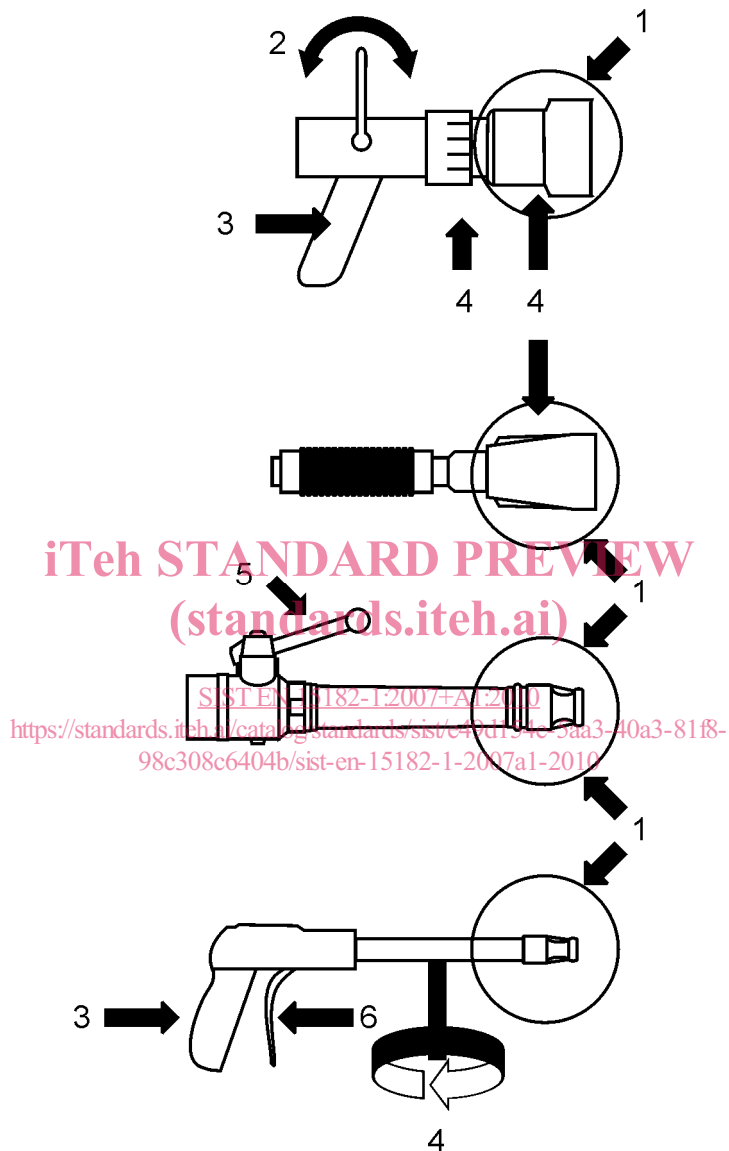

Key

- 1 nozzle
- 2 valve handle
- 3 handhold
- 4 rotating operating element
- 5 lever
- 6 trigger

Figure 1 — Components of a hand-held branchpipe shown without fitting systems

EN 15182-1:2007+A1:2009 (E)**5 Classification**

Branchpipes shall be classified in accordance with Annex A.

6 Requirements**6.1 Mechanical characteristics****6.1.1 Fitting systems**

Branchpipes from parts 2 and 4 of this standard with non rotating operation elements (e.g. valve handle, handhold, lever and trigger), shall be equipped with 360 ° fulltime swivelling inlet elements.

NOTE 1 Fitting systems are dealt with in national standards or requirements.

NOTE 2 Fitting systems should not impair the performance of the branchpipes.

6.1.2 Dimensions and mass

The dimensions and mass of the branchpipes (without inlet coupling) shall not exceed those given in parts 2, 3 and 4 of this standard.

6.1.3 Operating and handling elements**6.1.3.1 General**

NOTE Branchpipes should be ergonomically designed so that they can be easily operated without risk of injury when wearing firefighter's gloves complying with EN 659.

6.1.3.2 Operating and handling elements shall afford a firm hold and be able to resist the mechanical forces applied to them.

6.1.3.3 Handling elements shall be manufactured from a material which is insulated against cold or shall be provided with a protective cover.

NOTE This requirement is verified during the frost test in accordance with 7.2.2.

6.1.3.4 It shall be possible for the operator to control the speed of opening and closing the branchpipe.

NOTE Branchpipe shut-off should be easy to operate in a controlled manner to minimize the risk of water hammer.

6.1.3.5 For branchpipes of all types, rotating operating elements shall traverse from a wide spray jet to a narrow spray jet and to a straight jet, and from the greatest flow to the smallest flow, in a clockwise manner when viewed from the rear of the branchpipe.

6.1.3.6 A_1 Except for type 1 branchpipes, when A_1 rotating operating elements are used, it shall be possible to feel where the maximum flow rate setting is located, even when the operator is wearing firefighter's gloves complying with EN 659.

6.2 Materials

The materials used shall be selected so that all the requirements in clause 6 are met, subject to the tests defined in clause 7.

Branchpipes shall resist the heat and frost tests defined in 7.2 and to the drop test defined in 7.3.

6.3 Flush

6.3.1 When tested in accordance with 7.4, all branchpipes shall be able to clear or flush debris of the size specified in Table 1 without shutting off the branchpipe.

NOTE This can be accomplished either through the full open branchpipe position or through a flush feature of the branchpipe.

Table 1 — Flushing capability for branchpipes

Rated discharge	Size of steel ball
l/min	mm
Up to 250	3,18
250 to 500	4,76
over 500	6,35

6.3.2 Branchpipes equipped with a flush feature shall have a mechanical and/or visual device to indicate to the user when the flush feature is being engaged.

7 Testing and proofs

iTeh STANDARD PREVIEW
(standards.iteh.ai)

7.1 General

All the tests listed below are type tests. [SIST EN 15182-1:2007+A1:2010](http://standards.iteh.ai/catalog/standards/sist/e49d154e-5aa3-40a3-81f8-98c308c6404b/sist-en-15182-1-2007a1-2010)
<http://standards.iteh.ai/catalog/standards/sist/e49d154e-5aa3-40a3-81f8-98c308c6404b/sist-en-15182-1-2007a1-2010>

Unless otherwise specified, tests shall be carried out, at the reference pressure p_R , in the following order.

NOTE 1 Actual test results can be entered on the data sheet when these results exceed the minimum requirements given in this Standard.

NOTE 2 Guidance for acceptance tests on delivery is given in Annex B.

7.2 Heat and frost test

7.2.1 Sensitivity to heat

It shall be possible to use the branchpipe without restricting its function after it has been stored for 24 h at $(55 \pm 2) ^\circ\text{C}$.

NOTE Hand protection is recommended.

7.2.2 Sensitivity to frost

The branchpipe shall be uncoupled following operation for 1 min at the greatest possible flow rate and at the reference pressure p_R . It shall then be drained for 30 s and stored in the closed position at a temperature of $(-15 \pm 2) ^\circ\text{C}$ for 30 min. Following this, it shall still be possible to move the operating elements manually.

NOTE Hand protection is recommended.

7.3 Drop tests

7.3.1 General

The drop test shall start at maximum, within 3 min of the branchpipe being removed from the cooling chamber.

EN 15182-1:2007+A1:2009 (E)

The branchpipe shall be fully operational after being subjected to the drop tests.

7.3.2 Drop test 1

The branchpipe in the closed position shall be dropped from a height of 2 m onto a concrete surface so that it impacts directly or squarely on the nozzle (see Figure 2). It shall be set in the wide spray position if applicable.

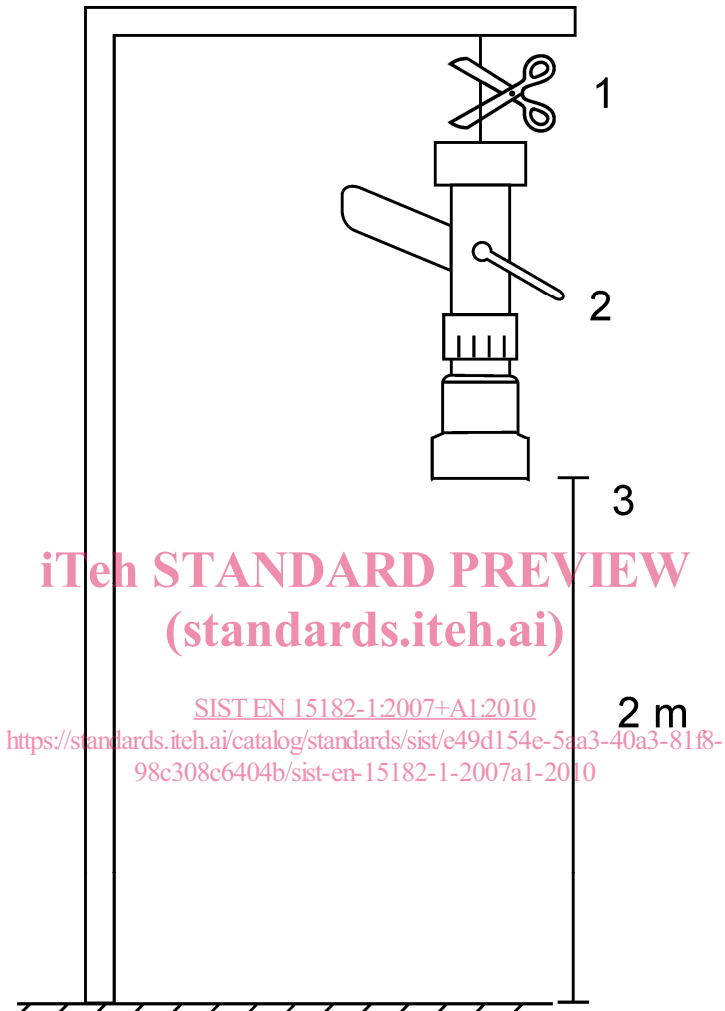

Key

- 1 attaching means
- 2 branchpipe
- 3 height

Figure 2 — Drop test 1

7.3.3 Drop test 2

The branchpipe shall be attached to a length of hose L at least 3 m long (see Figure 3). It shall be set in the wide spray position, if applicable.

The hose shall not be charged. The branchpipe shall then be dropped twice from a height H, of 2 m, onto a concrete surface so that the impact points are on opposing sides of the branchpipe. For a branchpipe equipped with a valve handle or lever, one of the points of impact shall be directly on that valve handle or lever while in the closed position.