



SLOVENSKI STANDARD

SIST EN 12350-8:2010

01-december-2010

Preskušanje svežega betona - 8. del: Samozgoščevalni beton - Preskus razleza s posedom

Testing fresh concrete - Part 8: Self-compacting concrete - Slump-flow test

Prüfung von Frischbeton - Teil 8: Selbstverdichtender Beton - Setzfließmaß-Prüfung

Essai pour béton frais - Partie 8: Béton auto-plaçant - Essai d'étalement au cône d'Abrams

ITeH STANDARD PREVIEW
(standards.iteh.ai)

Ta slovenski standard je istoveten z: EN 12350-8:2010

SIST EN 12350-8:2010
<https://standards.iteh.ai/catalog/standards/sist/2a4a83c6-6a7c-4189-b111-72935d8357f3/sist-en-12350-8-2010>

ICS:

91.100.30	Beton in betonski izdelki	Concrete and concrete products
-----------	---------------------------	--------------------------------

SIST EN 12350-8:2010

en,fr,de

iTeh STANDARD PREVIEW
(standards.iteh.ai)

SIST EN 12350-8:2010

<https://standards.iteh.ai/catalog/standards/sist/2a4a83c6-6a7c-4189-b111-72935d8357f3/sist-en-12350-8-2010>

EUROPEAN STANDARD

EN 12350-8

NORME EUROPÉENNE

EUROPÄISCHE NORM

July 2010

ICS 91.100.30

English Version

**Testing fresh concrete - Part 8: Self-compacting concrete -
Slump-flow test**Essai pour béton frais - Partie 8: Béton auto-plaçant - Essai
d'étalement au cône d'AbramsPrüfung von Frischbeton - Teil 8: Selbstverdichtender
Beton - Setzfließmaß-Prüfung

This European Standard was approved by CEN on 20 June 2010.

CEN members are bound to comply with the CEN/CENELEC Internal Regulations which stipulate the conditions for giving this European Standard the status of a national standard without any alteration. Up-to-date lists and bibliographical references concerning such national standards may be obtained on application to the CEN Management Centre or to any CEN member.

This European Standard exists in three official versions (English, French, German). A version in any other language made by translation under the responsibility of a CEN member into its own language and notified to the CEN Management Centre has the same status as the official versions.

CEN members are the national standards bodies of Austria, Belgium, Bulgaria, Croatia, Cyprus, Czech Republic, Denmark, Estonia, Finland, France, Germany, Greece, Hungary, Iceland, Ireland, Italy, Latvia, Lithuania, Luxembourg, Malta, Netherlands, Norway, Poland, Portugal, Romania, Slovakia, Slovenia, Spain, Sweden, Switzerland and United Kingdom.

SIST EN 12350-8:2010

<https://standards.iteh.ai/catalog/standards/sist/2a4a83c6-6a7c-4189-b111-72935d8357f3/sist-en-12350-8-2010>



EUROPEAN COMMITTEE FOR STANDARDIZATION
COMITÉ EUROPÉEN DE NORMALISATION
EUROPÄISCHES KOMITEE FÜR NORMUNG

Management Centre: Avenue Marnix 17, B-1000 Brussels

Contents

Page

Foreword.....	3
1 Scope	5
2 Normative references	5
3 Principle	5
4 Apparatus	5
5 Test sample	6
6 Procedure	7
7 Test result.....	7
8 Test report	7
9 Repeatability and reproducibility	8
Bibliography	9

iTeh STANDARD PREVIEW
(standards.iteh.ai)

SIST EN 12350-8:2010

<https://standards.iteh.ai/catalog/standards/sist/2a4a83c6-6a7c-4189-b111-72935d8357f3/sist-en-12350-8-2010>

Foreword

This document (EN 12350-8:2010) has been prepared by Technical Committee CEN/TC 104 "Concrete and related products", the secretariat of which is held by DIN.

This European Standard shall be given the status of a national standard, either by publication of an identical text or by endorsement, at the latest by January 2011, and conflicting national standards shall be withdrawn at the latest by January 2011.

Attention is drawn to the possibility that some of the elements of this document may be the subject of patent rights. CEN [and/or CENELEC] shall not be held responsible for identifying any or all such patent rights.

This document has been prepared under a mandate given to CEN by the European Commission and the European Free Trade Association, and supports essential requirements of EU Directive(s).

This standard is based on the results from the EU-project "Testing-SCC" under the 5th Frame Programme (GRD2-2000-30024/G6RD-CT-2001-00580).

Owing to its significant advantages in the improvement of construction quality and working environment, self-compacting concrete (SCC) has been widely accepted by the construction owners. The use of SCC in practical concrete construction is steadily increasing. Since SCC has to give satisfactory in-situ properties (perfect filling of the mould and embedment of the reinforcement, homogeneity and full compaction) without vibration, the proper methods for testing the fresh SCC are very important. These should address three key properties: filling ability, passing ability and resistance to segregation. It is desirable, especially in the case of new constituents or new concrete compositions, to test the consistence of fresh SCC before casting in place.

A number of test methods including this test are available for testing fresh SCC. Most of the commonly used test methods were evaluated in the recently closed EU-project "Testing-SCC" under the 5th Frame Programme (GRD2-2000-30024/G6RD-CT-2001-00580). According to the results from this EU project, it seems no single test method can completely cover all three key properties. Nevertheless any test method should at least be correlated to the practical situation and give consistent results in order to provide reliable data for judgment of concrete workability.

This standard is one of a series concerned with testing fresh concrete.

EN 12350, *Testing fresh concrete*, consists of the following parts:

- *Part 1: Sampling*
- *Part 2: Slump-test*
- *Part 3: Vebe test*
- *Part 4: Degree of compactability*
- *Part 5: Flow table test*
- *Part 6: Density*
- *Part 7: Air content — Pressure methods*
- *Part 8: Self-compacting concrete — Slump-flow test*

EN 12350-8:2010 (E)

- *Part 9: Self-compacting concrete — V-funnel test*
- *Part 10: Self-compacting concrete — L box test*
- *Part 11: Self-compacting concrete — Sieve segregation test*
- *Part 12: Self-compacting concrete — J-ring test*

CAUTION — When cement is mixed with water, alkali is released. Take precautions to avoid dry cement entering the eyes, mouth and nose whilst mixing concrete. Prevent skin contact with wet cement or concrete by wearing suitable protective clothing. If cement or concrete enters the eye, immediately wash it out thoroughly with clean water and seek medical treatment without delay. Wash wet concrete off the skin immediately.

According to the CEN/CENELEC Internal Regulations, the national standards organizations of the following countries are bound to implement this European Standard: Austria, Belgium, Bulgaria, Croatia, Cyprus, Czech Republic, Denmark, Estonia, Finland, France, Germany, Greece, Hungary, Iceland, Ireland, Italy, Latvia, Lithuania, Luxembourg, Malta, Netherlands, Norway, Poland, Portugal, Romania, Slovakia, Slovenia, Spain, Sweden, Switzerland and the United Kingdom.

iTeh STANDARD PREVIEW **(standards.iteh.ai)**

SIST EN 12350-8:2010

<https://standards.iteh.ai/catalog/standards/sist/2a4a83c6-6a7c-4189-b111-72935d8357f3/sist-en-12350-8-2010>

1 Scope

This European Standard specifies the procedure for determining the slump-flow and t_{500} time for self-compacting concrete. The test is not suitable when the maximum size of the aggregate exceeds 40 mm.

2 Normative references

The following referenced documents are indispensable for the application of this document. For dated references, only the edition cited applies. For undated references, the latest edition of the referenced document (including any amendments) applies.

EN 12350-1, *Testing fresh concrete — Part 1: Sampling*

EN 12350-2, *Testing fresh concrete — Part 2: Slump-test*

3 Principle

The slump-flow and t_{500} time is used to assess the flowability and the flow rate of self-compacting concrete in the absence of obstructions. It is based on the slump test described in EN 12350-2. The result is an indication of the filling ability of self-compacting concrete. The t_{500} time is a measure of the speed of flow and an indication of the relative viscosity of the self-compacting concrete.

The fresh concrete is poured into a cone as used for the EN 12350-2 slump test. When the cone is withdrawn upwards the time from commencing upward movement of the cone to when the concrete has flowed to a diameter of 500 mm is measured; this is the t_{500} time. The largest diameter of the flow spread of the concrete and the diameter of the spread at right angles to it are then measured and the mean is the slump-flow.

Measurement of the t_{500} time may be omitted if not requested.

4 Apparatus

The apparatus shall be in accordance with EN 12350-2 except as detailed below.

4.1 Baseplate, made from a flat steel plate, which shall be the reference material, with a plan area of at least 900 mm × 900 mm on which concrete can be placed.

The plate shall have a flat, smooth surface. If the plate is made from other materials, in-use performance test data shall be available which demonstrates long-term equivalence with steel plate.

The surface shall not be readily attacked by cement paste or be liable to rusting. The construction of the plate shall be such as to prevent distortion. The deviation from flatness shall not exceed 3 mm at any point when a straight edge is placed between opposing sides and corners.

The centre of the plate shall be scribed with a cross, the lines of which run parallel to the edges of the plate and with circles of (210 ± 1) mm diameter and (500 ± 1) mm diameter having their centres coincident with the centre point of the plate. See Figure 1. All lines to be a maximum of 2,0 mm wide and 1,0 mm deep.

4.2 Rule or measuring tape, of minimum length 1 000 mm and having sub-divisions not greater than 5 mm along its entire length.

4.3 Stop watch, capable of measuring to 0,1 s.

4.4 Spirit level, for checking horizontality of base plate prior to commencing the test.

EN 12350-8:2010 (E)

4.5 **Container**, to hold the test sample and having a volume of at least 10 l.

4.6 **Collar (optional)**, having a mass of at least 9 kg (see Figure 2).

NOTE The collar allows the test to be carried out by one person.

Dimensions in millimetres

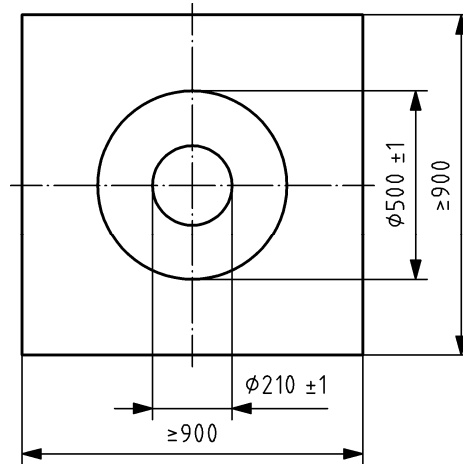

Figure 1 — Baseplate
 iTeh STANDARD PREVIEW
 (standards.iteh.ai)

Dimensions in millimetres

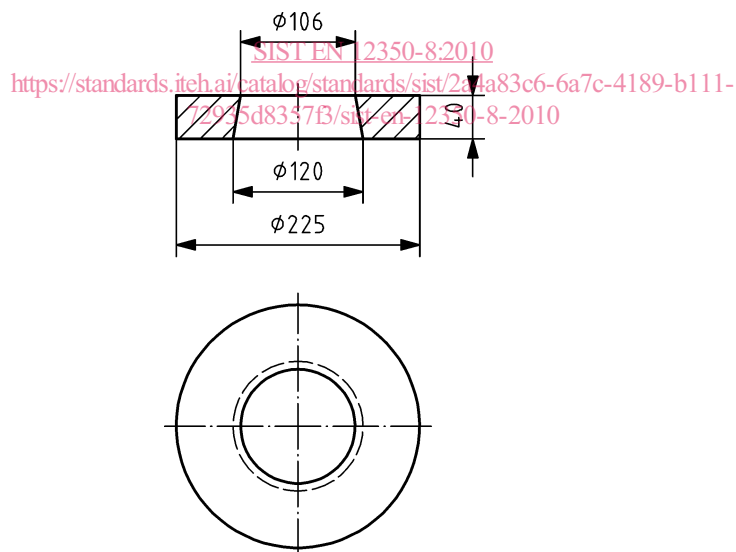

Figure 2 — Example of dimensions of a steelweighted collar

5 Test sample

The sample shall be obtained in accordance with EN 12350-1.

6 Procedure

Place the baseplate on a flat and horizontal surface free from external vibration or shock. Check the top surface for horizontality using the spirit level. Clean the table and the cone and dampen immediately prior to testing, but keep free from excess moisture.

Fit the collar to the cone if being used.

Place the cone centrally within the 210 mm circle on the baseplate and hold in position by standing on the foot pieces (or use the collar), ensuring that no concrete can leak from under the cone.

Fill the cone in one operation without any agitation or mechanical compaction, and strike off surplus from the top of the cone. Allow the filled cone to stand for not more than 30 s; during this time remove any spilled concrete from the baseplate.

Lift the cone vertically in 1 s to 3 s in one movement without interfering with the flow of concrete. If the t_{500} time has been requested, start the stop watch immediately the cone ceases to be in contact with the baseplate and record the time taken to the nearest 0,1 s for the concrete to first touch the 500 mm circle

After the flow of concrete has stabilized without disturbing the baseplate or concrete, measure the largest diameter of the flow spread and record as d_1 to the nearest 10 mm. Then measure the diameter of the flow spread at right angles to d_1 to the nearest 10 mm and record as d_2 to the nearest 10 mm. If the difference between d_1 and d_2 is greater than 50 mm another sample shall be taken and the procedure repeated.

If two consecutive tests show the difference between d_1 and d_2 to be greater than 50 mm, the concrete lacks the necessary flowability for the slump-flow test to be suitable.

Check the concrete spread for signs of segregation and report under item 8, f) in a qualitative way, e.g. no indication of segregation, strong indication of segregation.

NOTE Signs of segregation include a ring of cement paste/mortar and segregated coarse aggregate in the central area.

7 Test result

The slump-flow SF is the mean of d_1 and d_2 , expressed to the nearest 10 mm, given by the following equation.

$$SF = \frac{(d_1 + d_2)}{2}$$

where

SF is the slump-flow, in millimetres;

d_1 is the largest diameter of flow spread, in millimetres;

d_2 is the flow spread at 90° to d_1 , in millimetres.

The t_{500} time is reported to the nearest 0,5 s.

8 Test report

The test report shall include:

- a) identification of the test sample;