



SLOVENSKI STANDARD

SIST EN 12350-11:2010

01-december-2010

Preskušanje svežega betona - 11. del: Samozgoščevalni beton - Preskus segregacije s sitom

Testing fresh concrete - Part 11: Self-compacting concrete - Sieve segregation test

Prüfung von Frischbeton - Teil 11: Selbstverdichtender Beton - Bestimmung der Sedimentationsstabilität im Siebversuch

Essai pour béton frais - Partie 11: Béton auto-plaçant - Essai de stabilité au tamis

Ta slovenski standard je istoveten z: EN 12350-11:2010

SIST EN 12350-11:2010
<https://standards.iteh.ai/catalog/standards/sist/c0a56636-1b74-4809-888c-46f72e0beab1/sist-en-12350-11-2010>

ICS:

91.100.30 Beton in betonski izdelki Concrete and concrete products

SIST EN 12350-11:2010

en,fr,de

iTeh STANDARD PREVIEW
(standards.iteh.ai)

SIST EN 12350-11:2010

<https://standards.iteh.ai/catalog/standards/sist/c0a3b636-1b74-4809-888c-46f72e0beab1/sist-en-12350-11-2010>

EUROPEAN STANDARD

EN 12350-11

NORME EUROPÉENNE

EUROPÄISCHE NORM

July 2010

ICS 91.100.30

English Version

Testing fresh concrete - Part 11: Self-compacting concrete - Sieve segregation test

Essai pour béton frais - Partie 11: Béton auto-plaçant -
Essai de stabilité au tamis

Prüfung von Frischbeton - Teil 11: Selbstverdichtender
Beton - Bestimmung der Sedimentationsstabilität im
Siebversuch

This European Standard was approved by CEN on 20 June 2010.

CEN members are bound to comply with the CEN/CENELEC Internal Regulations which stipulate the conditions for giving this European Standard the status of a national standard without any alteration. Up-to-date lists and bibliographical references concerning such national standards may be obtained on application to the CEN Management Centre or to any CEN member.

This European Standard exists in three official versions (English, French, German). A version in any other language made by translation under the responsibility of a CEN member into its own language and notified to the CEN Management Centre has the same status as the official versions.

CEN members are the national standards bodies of Austria, Belgium, Bulgaria, Croatia, Cyprus, Czech Republic, Denmark, Estonia, Finland, France, Germany, Greece, Hungary, Iceland, Ireland, Italy, Latvia, Lithuania, Luxembourg, Malta, Netherlands, Norway, Poland, Portugal, Romania, Slovakia, Slovenia, Spain, Sweden, Switzerland and United Kingdom.

[SIST EN 12350-11:2010](https://standards.iteh.ai/catalog/standards/sist/c0a3b636-1b74-4809-888c-46f72e0beab1/sist-en-12350-11-2010)

<https://standards.iteh.ai/catalog/standards/sist/c0a3b636-1b74-4809-888c-46f72e0beab1/sist-en-12350-11-2010>



EUROPEAN COMMITTEE FOR STANDARDIZATION
COMITÉ EUROPÉEN DE NORMALISATION
EUROPÄISCHES KOMITEE FÜR NORMUNG

Management Centre: Avenue Marnix 17, B-1000 Brussels

Contents		Page
Foreword.....		3
1	Scope	5
2	Normative references	5
3	Principle	5
4	Apparatus	5
5	Test sample	5
6	Procedure	5
7	Test result.....	7
8	Test report	7
9	Repeatability and reproducibility	7
Bibliography		9

iTeh STANDARD PREVIEW
(standards.iteh.ai)

[SIST EN 12350-11:2010](https://standards.iteh.ai/catalog/standards/sist/c0a3b636-1b74-4809-888c-46f72e0beab1/sist-en-12350-11-2010)

<https://standards.iteh.ai/catalog/standards/sist/c0a3b636-1b74-4809-888c-46f72e0beab1/sist-en-12350-11-2010>

Foreword

This document (EN 12350-11:2010) has been prepared by Technical Committee CEN/TC 104 "Concrete and related products", the secretariat of which is held by DIN.

This European Standard shall be given the status of a national standard, either by publication of an identical text or by endorsement, at the latest by January 2011, and conflicting national standards shall be withdrawn at the latest by January 2011.

Attention is drawn to the possibility that some of the elements of this document may be the subject of patent rights. CEN [and/or CENELEC] shall not be held responsible for identifying any or all such patent rights.

This document has been prepared under a mandate given to CEN by the European Commission and the European Free Trade Association, and supports essential requirements of EU Directive(s).

This standard is based on the results from the EU-project "Testing-SCC" under the 5th Frame Programme (GRD2-2000-30024/G6RD-CT-2001-00580).

Owing to its significant advantages in the improvement of construction quality and working environment, self-compacting concrete (SCC) has been widely accepted by the construction owners. The use of SCC in practical concrete construction is steadily increasing. Since SCC has to give satisfactory in-situ properties (perfect filling of the mould and embedment of the reinforcement, homogeneity and full compaction) without vibration, the proper methods for testing the fresh SCC are very important. These should address three key properties: filling ability, passing ability and resistance to segregation. It is desirable, especially in the case of new constituents or new concrete compositions, to test the consistence of fresh SCC before casting in place.

A number of test methods including this test are available for testing fresh SCC. Most of the commonly used test methods were evaluated in the recently closed EU-project "Testing-SCC" under the 5th Frame Programme (GRD2-2000-30024/G6RD-CT-2001-00580). According to the results from this EU project, it seems that no single test method can completely cover all the three key properties. Nevertheless any test method should at least be correlated to the practical situation and give consistent results in order to provide reliable data for judgment of concrete consistence.

This standard is one of a series concerned with testing fresh concrete.

EN 12350, *Testing fresh concrete*, consists of the following parts:

- *Part 1: Sampling*
- *Part 2: Slump-test*
- *Part 3: Vebe test*
- *Part 4: Degree of compactability*
- *Part 5: Flow table test*
- *Part 6: Density*
- *Part 7: Air content — Pressure methods*
- *Part 8: Self-compacting concrete — Slump-flow test*

EN 12350-11:2010 (E)

- *Part 9: Self-compacting concrete — V-funnel test*
- *Part 10: Self-compacting concrete — L box test*
- *Part 11: Self-compacting concrete — Sieve segregation test*
- *Part 12: Self-compacting concrete — J-ring test*

CAUTION — When cement is mixed with water, alkali is released. Take precautions to avoid dry cement entering the eyes, mouth and nose whilst mixing concrete. Prevent skin contact with wet cement or concrete by wearing suitable protective clothing. If cement or concrete enters the eye, immediately wash it out thoroughly with clean water and seek medical treatment without delay. Wash wet concrete off the skin immediately.

According to the CEN/CENELEC Internal Regulations, the national standards organizations of the following countries are bound to implement this European Standard: Austria, Belgium, Bulgaria, Croatia, Cyprus, Czech Republic, Denmark, Estonia, Finland, France, Germany, Greece, Hungary, Iceland, Ireland, Italy, Latvia, Lithuania, Luxembourg, Malta, Netherlands, Norway, Poland, Portugal, Romania, Slovakia, Slovenia, Spain, Sweden, Switzerland and the United Kingdom.

iTeh STANDARD PREVIEW **(standards.iteh.ai)**

[SIST EN 12350-11:2010](https://standards.iteh.ai/catalog/standards/sist/c0a3b636-1b74-4809-888c-46f72e0beab1/sist-en-12350-11-2010)

<https://standards.iteh.ai/catalog/standards/sist/c0a3b636-1b74-4809-888c-46f72e0beab1/sist-en-12350-11-2010>

1 Scope

This European Standard specifies the procedure for determining the sieve segregation resistance of self-compacting concrete.

NOTE This test is not applicable to concrete containing fibres or lightweight aggregate.

2 Normative references

The following referenced documents are indispensable for the application of this document. For dated references, only the edition cited applies. For undated references, the latest edition of the referenced document (including any amendments) applies.

EN 12350-1, *Testing fresh concrete — Part 1: Sampling*

ISO 3310-2, *Test sieves — Technical requirements and testing — Part 2: Test sieves of perforated metal*

3 Principle

The sieve segregation resistance test is used to assess the resistance of self-compacting concrete to segregation.

After sampling, the fresh concrete is allowed to stand for 15 min and any separation of bleed water is noted. A defined top part of the sample is then poured onto a sieve with 5 mm square apertures. After 2 min the weight of material which has passed through the sieve is recorded. The segregation ratio is then calculated as the proportion of the sample and the material passing through the sieve.

<https://standards.iteh.ai/catalog/standards/sist/c0a3b636-1b74-4809-888c-46f72e0beab1/sist-en-12350-11-2010>

4 Apparatus

4.1 Perforated plate sieve, having 5 mm square apertures, frame diameter not less than 300 mm and a height of at least 30 mm, conforming to ISO 3310-2, complete with a receiver from which the sieve can easily be removed by lifting vertically.

4.2 Balance, having a flat platform which can accommodate the sieve receiver and having a capacity of at least 10 kg, capable of determining the mass to an accuracy of 0,01 kg.

4.3 Sample container, a rigid container made from a non-absorbent material and having a minimum internal diameter of 200 mm and a capacity of at least 11 l with a 10 l point indicated on the inside of the container.

4.4 Timer, capable of measuring to 1 s.

4.5 Thermometer, capable of measuring to 1 °C.

5 Test sample

A sample shall be obtained in accordance with EN 12350-1.

6 Procedure

Take and record the temperature of the concrete to the nearest 1 °C by using the thermometer.

EN 12350-11:2010 (E)

Place $(10 \pm 0,5)$ l of concrete in the sample container and cover to prevent evaporation (see Figure 1).

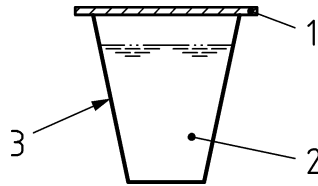

Key

- 1 Cover
- 2 Concrete
- 3 Sample container

Figure 1 — Sample container and cover

Allow to stand in a level position, without disturbance, for $(15 \pm 0,5)$ min.

Ensure the balance is level and free from vibration. Place the sieve receiver on the balance and record its mass, m_p in grams. Then place the dry sieve on the receiver and again record the mass or zero the balance.

At the end of the standing period remove the cover from the sample container and record whether any bleed water has appeared on the surface of the concrete.

With the sieve and receiver still on the balance, and with the top of the sample container (500 ± 50) mm above the sieve, steadily and carefully pour $(4,8 \pm 0,2)$ kg of concrete (including any bleed water) onto the centre of the sieve (see Figure 2) in one operation. Record the actual mass of concrete m_c in grams on the sieve.

<https://standards.iteh.ai/catalog/standards/sist/c0a3b636-1b74-4809-888c-46f72e0beab1/sist-en-12350-11-2010> Dimensions in millimetres

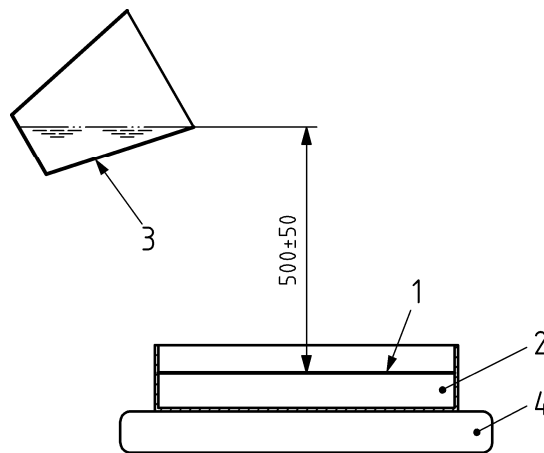

Key

- 1 Sieve
- 2 Sieve receiver
- 3 Sample container
- 4 Balance

Figure 2 — Measurement of segregated portion

Allow the concrete to stand in the sieve for (120 ± 5) s and then remove the sieve vertically without agitation.

Record the mass of the receiver, including the material that has passed through the sieve, m_{ps} in grams.

7 Test result

The segregated portion SR is calculated from the following equation and reported to the nearest 1 %.

$$SR = \frac{(m_{ps} - m_p) \times 100}{m_c}$$

where

- SR is the segregated portion in percent;
- m_{ps} is the mass of sieve receiver plus passed material, in grams;
- m_p is the mass of the sieve receiver, in grams;
- m_c is the initial mass of concrete placed onto the sieve, in grams.

8 Test report

The test report shall include:

- a) identification of the test sample;
- b) location where the test was performed;
- c) date and time of test;
- d) temperature of the concrete at the time of test, to the nearest 1 °C;
- e) presence of bleed water, if any, after standing for 15 min;
- f) segregated portion SR , to the nearest 1 %;
- g) any deviation from the standard test method;
- h) declaration by the person technically responsible for the test that it was carried out in accordance with this standard, except as noted in item g).

The report may include:

- i) age of concrete at time of test (if known).

9 Repeatability and reproducibility

The repeatability r and reproducibility R have been determined by a programme including eleven laboratories, 22 operators and two replicates, and interpreted in accordance with ISO 5725-2.

The resulting values for r and R are given in Table 1.