



Designation: B 438/B 438M – 04

Standard Specification for Sintered Bronze Bearings (Oil-Impregnated)¹

This standard is issued under the fixed designation B 438/B 438M; the number immediately following the designation indicates the year of original adoption or, in the case of revision, the year of last revision. A number in parentheses indicates the year of last reappraisal. A superscript epsilon (ϵ) indicates an editorial change since the last revision or reappraisal.

This standard has been approved for use by agencies of the Department of Defense.

1. Scope

1.1 This specification covers sintered bronze, oil-impregnated bearings made primarily from elemental copper, tin, and graphite powders. The manufacturer may, at his discretion, use prealloyed bronze powder in the blend.

1.2 This specification covers the following variables:

1.2.1 *Grades*—Available in four bronze base composition grades identifiable by different graphite contents.

1.2.2 *Type*—Grades 1 and 2 are available in four types described by specific density ranges.

1.3 Bearings ordered to this specification will normally be sized after sintering and will be impregnated with a lubricating oil unless otherwise specified by print.

1.4 The values stated in either inch-pound or SI units are to be regarded separately as standard. Within the text, the SI units are shown in brackets. The values stated in each system are not exact equivalents; therefore, each system shall be used independently of the other. Combining values from the two systems may result in nonconformance with the specification.

2. Referenced Documents

2.1 *ASTM Standards*:²

B 328 Test Method for Density, Oil Content, and Interconnected Porosity of Sintered Metal Structural Parts and Oil-Impregnated Bearings

E 9 Test Methods of Compression Testing of Metallic Materials at Room Temperature

2.2 *Government Standards*:

MIL-PRF-6085 Lubricating Oil: Instrument, Aircraft, Low Volatility³

MIL-PRF-17331 Lubrication Oil: Steam Turbine and Gear, Moderate Service³

¹ This specification is under the jurisdiction of ASTM Committee B09 on Metal Powders and Metal Powder Products and is the direct responsibility of Subcommittee B09.04 on Bearings.

Current edition approved April 1, 2004. Published May 2004. Originally approved in 1966. Last previous edition approved in 2000 as B 438 – 00a.

² For referenced ASTM standards, visit the ASTM website, www.astm.org, or contact ASTM Customer Service at service@astm.org. For *Annual Book of ASTM Standards* volume information, refer to the standard's Document Summary page on the ASTM website.

³ Available from Standardization Documents Order Desk, Bldg. 4 Section D, 700 Robbins Ave., Philadelphia, PA 19111–5094, Attn: NPODS.

FED-STD-151 Metals Test Method³

3. Ordering Information

3.1 Orders for parts under this specification shall include the following information:

3.1.1 Dimensions and tolerances (Section 9),

3.1.2 Grade and type,

3.1.3 Density specification (Table 1 and Table 2), and

3.1.4 Oil type.

4. Materials and Manufacture

4.1 Sintered bronze bearings shall be made by molding or briquetting metal powder mixtures to the proper density. The green bearing shall be sintered at a time–temperature relationship to produce a microstructure that is essentially alpha bronze and contains no tin-rich phases visible at 300 \times . Sintered bronze bearings are normally sized after sintering to maintain the dimensional characteristics required of the bearing. After sizing and inspection, they are impregnated with a lubricating oil unless otherwise specified.

5. Chemical Composition

5.1 The material shall conform to the requirements as to the chemical composition prescribed in Table 3.

6. Physical Properties

6.1 *Density*—The density of bearings supplied impregnated with lubricant shall be within the limits prescribed in Table 1 and Table 2, when determined in accordance with Test Method B 328.

6.2 *Oil Content*—Oil content of bearings shall not be less than shown in Table 4 for each grade and type when determined in accordance with Test Method B 328.

7. Mechanical Properties

7.1 The manufacturer and purchaser shall agree on a representative number of specimens for tests.

7.2 *Radial Crushing Force*—Radial crushing force shall be determined by compressing the test specimen between two flat steel surfaces at a “no load” speed not greater than 0.2 in./min [5.0 mm/min], the direction of the load being normal to the longitudinal axis of the specimen. The point at which the load

TABLE 1 Density Requirements (Oil Impregnated)

	Type	Density, g/cm ³
Grades 1 and 2	1	5.8–6.2 ^A
Grades 1, 2, and 4	2	6.4–6.8
Grades 1 and 2	3	6.8–7.2
Grades 1 and 2	4	7.2–7.6

^A Maximum density limit of 6.2 g/cm³ has been established on Type 1 to ensure meeting an oil content of 27 % minimum. Satisfactory bearings can also be produced between Type 1 and Type 2. These bearings have slightly higher strength constants and slightly lower oil content.

TABLE 2 Density Requirements (Oil Impregnated)

	Type	Density, g/cm ³
Grade 3	1	5.8–6.2
	2	6.2–6.6

TABLE 3 Chemical Requirements (Composition, %)

Element	Grade 1	Grade 2	Grade 3	Grade 4
Copper	87.2–90.5	85.7–90.0	82.8–88.3	80.9–88.0
Tin	9.5–10.5	9.5–10.5	9.2–10.2	9.5–10.5
Graphite	0–0.3	0.5–1.8	2.5–5.0	0.50–1.75
Iron, max	1.0	1.0	1.0	1.0
Total other elements by difference, max	1.0	1.0	1.0	0.5
Lead				2.0–4.0
Zinc, max				0.75
Nickel, max				0.35
Antimony, max				0.25

NOTE—Grade 4 to be used for special government needs.

TABLE 4 Oil Content (Oil Content, Volume %, Min)

Type	Grade 1	Grade 2	Grade 3	Grade 4
1	27	25	11 ^A	...
2	19	17	... ^B	17
3	12	9
4	9	7

^A At 3 % graphite, Type 1 will contain 14 % min oil content.

^B At 3 % graphite, Type 2 will contain 8 % min oil content. At 5 % graphite, Type 2 will contain only a minimal amount of oil.

drops as a result of the first crack shall be considered the crushing strength. This test shall be applied to plain cylindrical bearings. Flanged bearings shall be tested by cutting off the flange and compressing the two sections separately. Each section shall meet the minimum strength requirements prescribed in **Table 5**.

7.2.1 Radial crushing force shall not be less than the value calculated as follows:

$$P = KLT^2/(D-T) \quad (1)$$

TABLE 5 Strength Constant *K* (Strength Constants, Min),^A psi [MPa]

Type	Grade 1	Grade 2	Grade 3	Grade 4
1	15 000 [105]	13 000 [90]	10 000 [70]	... [...]
2	26 000 [180]	23 000 [160]	15 000 [105]	23 000 [160]
3	37 000 [255]	30 000 [205]	... [...]	... [...]
4	40 000 [275]	34 000 [235]	... [...]	... [...]

^A For the *K* value specification to be valid, wall thickness must be less than one third of the outside diameter.

where:

P = radial crushing force, pounds [N],

D = outside diameter of bearing, inches [mm],

T = wall thickness of bearing, inches [mm],

K = strength constant as shown in **Table 5** for grade and type specified, psi [MPa], and

L = length of bearing, inches [mm].

7.2.2 Concerning spherical bearings, sample parts from a lot will be machined to a straight wall and radially crushed to calculate the *K* value. Sample parts from the same lot will be radially crushed as is (whole part). By correlation, the minimum radial crush value will be established on the whole bearing and so specified as the minimum radial crush value for the part.

8. Chemical Analysis

8.1 If required by purchase agreement, one sample for chemical analysis shall be taken from each lot. A representative sample of chips may be obtained by milling, drilling, filing, or crushing a bearing with clean dry tools without lubrication. To obtain oil-free chips, the parts selected for test shall have the oil extracted in accordance with Test Method **B 328** if necessary.

8.2 The chemical analysis shall be made in accordance with the methods prescribed in Vol 03.05 of the *Annual Book of ASTM Standards* or by any other method agreed upon between the manufacturer and the purchaser.

9. Dimensions and Tolerances

9.1 Permissible variations in dimensions shall be within the limits specified on the drawings describing the bearings accompanying the order or shall be within the limits specified on the order.

10. Workmanship, Finish, and Appearance

10.1 Bearings shall be uniform in composition, clean, and conform to applicable drawings.

11. Sampling

11.1 *Lot*—Unless otherwise specified, a lot shall consist of parts of the same form and dimensions made from powders of the same composition, formed and sintered under the same conditions, and submitted for inspection at one time.

12. Inspection

12.1 Unless otherwise specified, inspection of parts supplied on contract shall be made by the purchaser at the destination.

13. Rejection

13.1 Parts that fail to conform to the requirements of this specification may be rejected. Rejection should be reported to the producer or supplier promptly and in writing.

14. Certification

14.1 When specified in the purchase order or contract, a producer's certification shall be furnished to the purchaser that

the parts were manufactured, sampled, tested, and inspected in accordance with this specification and have been found to meet the requirements. When specified in the purchase order or contract, a report of the test results shall be furnished.

14.2 The purchase order must specify whether or not the certification includes chemistry.

14.3 Upon request of the purchaser in the contract or order, the certification of an independent third party indicating conformance to the requirements of this specification may be considered.

15. *Supplementary Requirements* Supplementary Requirements

15.1 For some materials, supplementary requirements may be specified. Usually these apply only when specified by the purchaser in the inquiry, contract, or order. These supplementary requirements shall appear separately.

15.2 *Special Government Requirements*—Requirements that are special to government needs are listed in 15.2.1 through 15.2.9.

15.2.1 Materials shall conform to Table 3, Grade 4. Contractor shall furnish a percent composition analysis on an oil-free basis for each lot showing the percentage for each element as specified in Table 3. Bearing shall conform to this specification and supporting military specification as applicable.

15.2.2 High-grade nongumming petroleum lubricants, such as MIL-PRF-6085, MIL-PRF-17331 (Military Symbol 2190–TEP), or as specified on referenced military standard specification sheets shall be used to impregnate the bearings.

15.2.3 When specified, a first-article inspection shall be performed on bearings. Four samples shall be made available for first-article inspection and tested for chemical requirements, density, porosity, radial crushing strength, oil excretion, and dimensional characteristics as specified herein, Test Method B 328, FED-STD-151, or in an otherwise specified document. Any defect or failure shall be cause for rejection of the lot. Waivers for minor defects may be addressed to the contracting officer.

15.2.4 When procured from a contractor versus the actual manufacturer, a certificate of quality conformance (COQC) supplied by the manufacturer of the bearing may be furnished in lieu of actual performance of such testing by the contractor,

provided lot identity has been maintained and can be demonstrated to the Government. The certificate shall include the name of the contractor, contractor number, name of manufacturer, NSN, item identification, name of the component or material, lot number, lot size, dimensions, date of testing, test method, individual test results, and specification requirements.

15.2.5 When specified in the contract or purchase order, packaging and marking shall be completed in accordance with the provisions of the contract.

15.2.6 Oil excretion of the bearing shall be verified by placing the bearing in the chamber of a preheated oven. Oven temperature shall be nominally 300°F [149°C]. Exposure shall be 5 min. During the period, beads shall exude uniformly from the bearing surface. Lack of appreciable sweating of the lubricant on the bearing surface will be cause for rejection. Lubricant content may be verified using Test Method B 328.

15.2.7 Unless otherwise specified, the contractor is responsible for testing. The contractor may use their own or any other suitable facility for the performance of testing and inspection, unless an exception is stated. The Government reserves the right to perform an inspection set forth herein to assure supplies and sources conform to the prescribed requirements.

15.2.8 Records of examination and tests performed by or for the contractor shall be maintained and made available to the Government by the contractor for a period of three years after delivery of the products and associate material.

15.2.9 All requirements shall be as specified herein. Reference military standard specification sheets shall take precedence unless otherwise specified in the contract or purchase order.

16. Related Specifications

16.1 *MPIF Standards*:

16.1.1 MPIF Standard 35—Material Standard 35 for P/M Self Lubricating Bearings.

16.2 *ISO Standards*:

16.2.1 2795—Plain Bearings Made From Sintered Material—Dimensions and Tolerances.

16.2.2 5755—Sintered Metal Material Specifications.

17. Keywords

17.1 density; *K* strength constant; oil content; oil-impregnated bearings; porosity

X1. EXPLANATORY INFORMATION

X1.1 Design Information

X1.1.1 In calculating permissible loads, the operating conditions, housing conditions, and construction should be considered. The maximum static bearing load should not exceed 8500 psi [60 MPa] of projected bearing area (length times inside diameter of bearing) for this material. This figure is 75 % of the value for the compression deformation limit [yield strength, permanent set of 0.001 in. [0.025 mm] for specimens 1½ in. [30 mm] in diameter and 1 in. [25 mm] in length] as determined in accordance with Test Methods E 9.

X1.2 Permissible Loads

X1.2.1 Permissible loads for various operating conditions are given in **Table X1.1**.

X1.3 Dimensional Tolerances

X1.3.1 Commercial dimensional tolerances are included in **Table X1.2**. Closer tolerances can be held with special tooling or processing, or both.

X1.3.2 The commercial tolerances listed in **Table X1.2** are intended for bearings with a 4 to 1 maximum length to inside diameter ratio and a 24 to 1 maximum length to wall thickness ratio.

X1.3.3 **Fig. X1.1**, **Fig. X1.2**, and **Fig. X1.3** illustrate standard sleeve, standard flange bearings, and standard thrust bearings, respectively. Their dimensions are referenced

TABLE X1.2 Commercial Dimensional Tolerances

Inside Diameter, <i>d</i> , and Outside Diameter, <i>D</i> , in. [mm]		Total Diameter Tolerances, in. [mm]		
Over	Through			
...	1 [25]	0.001 [0.025]		
1 [25]	1.5 [40]	0.0015 [0.04]		
1.5 [40]	2 [50]	0.002 [0.05]		
2 [50]	2.5 [65]	0.0025 [0.064]		
2.5 [65]	3 [75]	0.003 [0.076]		
Length Tolerances, <i>L</i> , in. [mm]				
Over	Through	±		
...	1.5 [40]	0.005 [0.13]		
1.5 [40]	3 [75]	0.010 [0.25]		
3 [75]	4.5 [115]	0.015 [0.38]		
Outside Diameter, <i>D</i> , in. [mm]		Length, <i>L</i> , in. [mm]		Concentricity, ±in. [mm]
Over	Through	Over	Through	
...	1 [25]	0 [0]	0 [25]	0.003 [0.08]
...	1 [25]	1 [25]	1.5 [40]	0.004 [0.1]
...	1 [25]	1.5 [40]	2 [50]	0.004 [0.1]
...	1 [25]	2 [50]	2.5 [65]	0.005 [0.13]
...	1 [25]	2.5 [65]	3 [75]	0.005 [0.13]
1 [25]	2 [50]	0 [0]	1 [25]	0.004 [0.1]
1 [25]	2 [50]	1 [25]	1.5 [40]	0.005 [0.13]
1 [25]	2 [50]	1.5 [40]	2 [50]	0.005 [0.13]
1 [25]	2 [50]	2 [50]	2.5 [65]	0.006 [0.15]
1 [25]	2 [50]	2.5 [65]	3 [75]	0.006 [0.15]
2 [50]	3 [75]	0 [0]	1 [25]	0.005 [0.13]
2 [50]	3 [75]	1 [25]	1.5 [40]	0.006 [0.15]
2 [50]	3 [75]	1.5 [40]	2 [50]	0.006 [0.15]
2 [50]	3 [75]	2 [50]	2.5 [65]	0.007 [0.18]
2 [50]	3 [75]	2.5 [65]	3 [75]	0.007 [0.18]

TABLE X1.1 Permissible Loads

Shaft Velocity, ft/min [m/s]	Permissible Loads, psi [MPa]			
	Grades 1, 2, 3, and 4			
	Type I	Type II	Type III	Type IV
Slow and intermittent 25 [0.125]	3200 [22]	4000 [28]	4000 [28]	4000 [28]
50 to 100 [0.25–0.50], incl	2000 [14]	2000 [14]	2000 [14]	2000 [14]
Over 100 to 150 [0.50–0.75], incl	500 [3.4]	550 [3.9]	550 [3.9]	550 [3.9]
Over 150 to 200 [0.75–1.00], incl	325 [2.2]	365 [2.5]	365 [2.5]	365 [2.5]
Over 200 [1.00]	250 [1.7]	280 [1.9]	280 [1.9]	280 [1.9]
	A	A	A	A

^A For shaft velocities over 200 ft/min [1.00 m/s], the permissible loads may be calculated as follows:

$$P = 50\,000/V[1.75/V] \quad (1)$$

where:

- P* = safe load, psi [MPa] of projected area, and
- V* = shaft velocity, ft/min [m/s].

NOTE 1—With a shaft velocity of less than 50 ft/min [0.25 m/s] and a permissible load greater than 1000 psi [0.15 MPa], an extreme pressure lubricant should be used.

NOTE 2—With good heat dissipation and heat removal techniques, higher PV ratings can be obtained.

Chamfer Tolerances		
Wall Thickness (<i>D-d</i>) ^{1/2}		Chamfer, <i>C</i> , max, in. [mm]
in. Over	Through	
...	0.040 [1]	0.008 [0.2]
0.040 [1]	0.080 [2]	0.012 [0.3]
0.080 [2]	0.120 [3]	0.016 [0.4]
0.120 [3]	0.160 [4]	0.025 [0.6]
0.160 [4]	0.200 [5]	0.030 [0.8]
0.200 [5]	...	0.030 [0.8]
Angularity		Tolerance, ±
45° (from the face)		5°

throughout the tolerance tables. Standard chamfer tolerances are also listed in **Table X1.2**.

X1.4 Press Fits

X1.4.1 Plain cylindrical journal bearings are commonly installed by press fitting the bearing into a housing with an insertion arbor. For housings rigid enough to withstand the

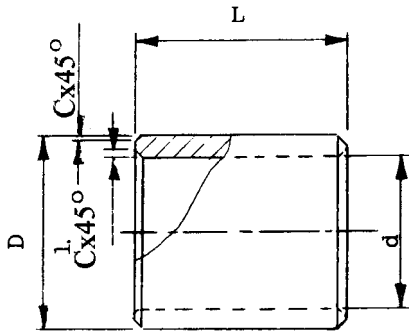

FIG. X1.1 Standard Sleeve Bearing

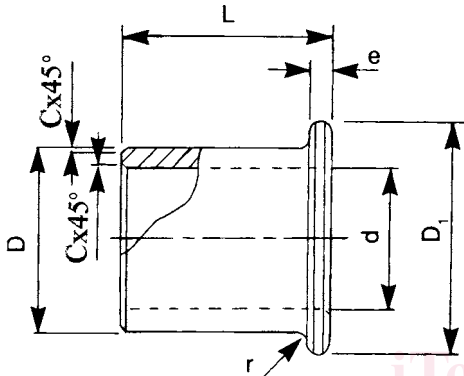

FIG. X1.2 Standard Flange Bearing

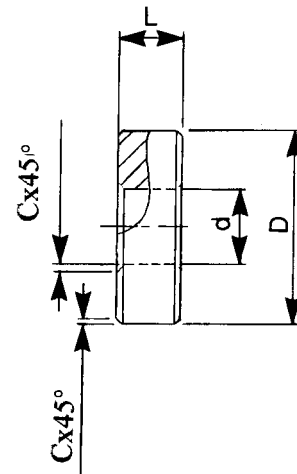

FIG. X1.3 Standard Thrust Bearing

TABLE X1.3 Recommended Press Fits

Outside Diameter of Bearing, in. [mm]		Press Fit	
Over	Through	min, in. [mm]	max, in. [mm]
0.000 [0.000]	0.760 [20]	0.001 [0.025]	0.003 [0.08]
0.760 [20]	1.510 [40]	0.0015 [0.04]	0.004 [0.10]
1.510 [40]	2.510 [63]	0.002 [0.05]	0.005 [0.13]
2.510 [63]	3.010 [75]	0.002 [0.05]	0.006 [0.15]
3.010 [75]	...	0.002 [0.05]	0.007 [0.18]

TABLE X1.4 Running Clearances

Shaft Size, in. [mm]		Clearance, min, in. [mm]
Over	Through	
0.000 [0.000]	0.250 [6]	0.0003 [0.008]
0.250 [6]	0.760 [20]	0.0005 [0.013]
0.760 [20]	1.510 [40]	0.0010 [0.025]
1.510 [40]	2.510 [60]	0.0015 [0.040]
2.510 [60]	... [...]	0.0020 [0.050]

press fit without appreciable distortion and for bearings with wall thickness approximately one eighth of the bearing outside diameter, the press fits shown in Table X1.3 are recommended.

X1.5 Running Clearance

X1.5.1 Proper running clearance for sintered bearings depends to a great extent on the particular application. Therefore, only minimum recommended clearances are listed in Table X1.4. The maximum running clearances will automatically be held within good design practice for average conditions. It is assumed that ground steel shafting having a recommended finish of 4 to 16 root mean square (rms) will be used and all bearings will be oil impregnated.

X1.6 Flange and Thrust Bearing Specifications

X1.6.1 Diameter and thickness specifications for flange and thrust washers are shown in Table X1.5.

X1.7 Lubricating Oil-Impregnant

X1.7.1 It was found that the high-grade turbine oil containing rust and oxidation inhibitors and antifoam additives is the most desirable type of oil to be used. The viscosity should be specified by the user in accordance with the application.

TABLE X1.5 Flange and Thrust Bearings Diameter and Thickness Tolerances^A

Flange Bearings, Flange Diameter Tolerances			
Diameter Range, in. [mm]		Standard (Tolerance), in. [mm]	Special (Tolerance), in. [mm]
Over	Through		
0 [0]	1½ [40]	±0.005 [±0.13]	±0.0025 [±0.06]
1½ [40]	3 [75]	±0.010 [±0.25]	±0.005 [±0.13]
3 [75]	6 [150]	±0.025 [±0.63]	±0.010 [±0.25]
Flange Bearings, Flange Thickness Tolerances			
Diameter Range, in. [mm]		Standard (Tolerance), in. [mm]	Special (Tolerance), in. [mm]
Over	Through		
0 [0]	1½ [40]	±0.005 [±0.13]	±0.0025 [±0.06]
1½ [40]	3 [75]	±0.010 [±0.25]	±0.007 [±0.20]
3 [75]	6 [150]	±0.015 [±0.40]	±0.010 [±0.25]
Flange Bearings, Radius, <i>r</i> , Tolerance			
Outside Diameter, <i>D</i> , in. [mm]		Radius, <i>r</i> , max, in. [mm]	
Over	Through		
0 [0]	0.475 [12]	0.012 [0.3]	
0.475 [12]	1.200 [30]	0.024 [0.6]	
1.20 [30]	... [...]	0.031 [0.8]	
Thrust Bearings (¼-in. [6.35-mm] Thickness, max), Thickness Tolerances for All Diameters ^B			
Standard (Tolerance), in. [mm]		Special (Tolerance), in. [mm]	
+0.005 [±0.13]		+0.0025 [±0.06]	
Parallelism of Faces, max			
Diameter Range, in. [mm]		Standard (Tolerance), in. [mm]	Special (Tolerance), in. [mm]
Over	Through		
0 [0]	1½ [40]	0.003 [0.08]	0.002 [0.05]
1½ [40]	3 [75]	0.004 [0.10]	0.003 [0.08]
3 [75]	6 [150]	0.005 [0.13]	0.004 [0.10]

^A Standard and special tolerances are specified for diameters, thickness, and parallelism. Special tolerances should not be specified unless required since they require additional or secondary operations and, therefore, are costlier.

^B Outside diameter tolerances are the same as for flange bearings.

ASTM B438/B438M-04

<https://standards.iteh.ai/catalog/standards/sist/592738/astm-b438-b438m-04> **X2. MILITARY BEARING, SLEEVE, FLANGED, SINTERED BRONZE, OIL IMPREGNATED** <https://standards.iteh.ai/catalog/standards/sist/592738/astm-b438-b438m-04>

This specification sheet is approved for use by all Departments and Agencies of the Department of Defense.

X2.1 Requirements

X2.1.1 The information contained in this appendix was derived from MS17796 rev A, dated 9 Nov 1984, and is intended to provide special bearing requirements for military use.

X2.1.1.1 These bearings are not intended for reaming on assembly.

X2.1.1.2 *Material*—Sintered bronze, oil-impregnated bearings made primarily from elemental copper, tin and graphite powders in accordance with ASTM B 438/B 438M, type 2, grade 2 or type 2, grade 4 (note: the grade must be specified in the contract).

X2.2 Notes

X2.2.1 The military part or identifying number (PIN) shall consist of the letters B09, 438X2 where X2 is the B438 appendix number, and a dash number from **Table X2.1**.

Example: B09-438X2-104

where:

- B09 = B09
- 438X2 = ASTM Standard and Appendix number
- 104 = Dash number

NOTE X2.1—The B09-438X2-104 identifying number equates to the old MS 17796-104 designation where the MS 17796 represented the military sheet specification number and 104 was the dash number. The dash numbers remain unchanged from the MS 17796.

X2.2.2 Referenced documents shall be of the issue in effect on the date of invitations for bids or request for proposals, except that referenced adopted industry documents shall give the date of the issue adopted.

X2.2.3 In the event of a conflict between the text of this document and the references cited herein, the text of this document takes precedence.

X2.2.4 The bearings described in this document are not recommended for military airframe applications.