**Water-cooled secondary connection cables
for resistance welding —**

Part 2:
**Dimensions and requirements for single-
conductor connection cables**

iTeh **STANDARD PREVIEW**

Câbles secondaires refroidis par eau pour le soudage par résistance —

(standards.iteh.ai)

Partie 2: Dimensions et exigences pour câbles à un conducteur

ISO 8205-2:2002

<https://standards.iteh.ai/catalog/standards/sist/936f0bbf-7f1b-4164-aa32-c3d26fb3d8d9/iso-8205-2-2002>



PDF disclaimer

This PDF file may contain embedded typefaces. In accordance with Adobe's licensing policy, this file may be printed or viewed but shall not be edited unless the typefaces which are embedded are licensed to and installed on the computer performing the editing. In downloading this file, parties accept therein the responsibility of not infringing Adobe's licensing policy. The ISO Central Secretariat accepts no liability in this area.

Adobe is a trademark of Adobe Systems Incorporated.

Details of the software products used to create this PDF file can be found in the General Info relative to the file; the PDF-creation parameters were optimized for printing. Every care has been taken to ensure that the file is suitable for use by ISO member bodies. In the unlikely event that a problem relating to it is found, please inform the Central Secretariat at the address given below.

iTeh STANDARD PREVIEW
(standards.iteh.ai)

ISO 8205-2:2002

<https://standards.iteh.ai/catalog/standards/sist/936f0bbf-7f1b-4164-aa32-c3d26fb3d8d9/iso-8205-2-2002>

© ISO 2002

All rights reserved. Unless otherwise specified, no part of this publication may be reproduced or utilized in any form or by any means, electronic or mechanical, including photocopying and microfilm, without permission in writing from either ISO at the address below or ISO's member body in the country of the requester.

ISO copyright office
Case postale 56 • CH-1211 Geneva 20
Tel. + 41 22 749 01 11
Fax + 41 22 749 09 47
E-mail copyright@iso.ch
Web www.iso.ch

Printed in Switzerland

Foreword

ISO (the International Organization for Standardization) is a worldwide federation of national standards bodies (ISO member bodies). The work of preparing International Standards is normally carried out through ISO technical committees. Each member body interested in a subject for which a technical committee has been established has the right to be represented on that committee. International organizations, governmental and non-governmental, in liaison with ISO, also take part in the work. ISO collaborates closely with the International Electrotechnical Commission (IEC) on all matters of electrotechnical standardization.

International Standards are drafted in accordance with the rules given in the ISO/IEC Directives, Part 3.

Draft International Standards adopted by the technical committees are circulated to the member bodies for voting. Publication as an International Standard requires approval by at least 75 % of the member bodies casting a vote.

Attention is drawn to the possibility that some of the elements of this part of ISO 8205 may be the subject of patent rights. ISO shall not be held responsible for identifying any or all such patent rights.

International Standard ISO 8205-2 was prepared by Technical Committee ISO/TC 44, *Welding and allied processes*, Subcommittee SC 6, *Resistance welding*.

This second edition cancels and replaces the first edition (ISO 8205-2:1993), which has been technically revised.

ISO 8205 consists of the following parts, under the general title *Water-cooled secondary connection cables for resistance welding*:

- Part 1: Dimensions and requirements for double-conductor connection cables
- Part 2: Dimensions and requirements for single-conductor connection cables
- Part 3: Test requirements

iTeh STANDARD PREVIEW
(standards.iteh.ai)

ISO 8205-2:2002

<https://standards.iteh.ai/catalog/standards/sist/936f0bbf-7f1b-4164-aa32-c3d26fb3d8d9/iso-8205-2-2002>

Water-cooled secondary connection cables for resistance welding —

Part 2:

Dimensions and requirements for single-conductor connection cables

1 Scope

This part of ISO 8205 specifies the dimensions of single-conductor connection cables used for resistance welding and allied processes. It stipulates the requirements regarding the electrical, mechanical and cooling characteristics of these cables and their conditions of use.

2 Normative reference

The following normative document contains provisions which, through reference in this text, constitute provisions of this part of ISO 8205. For dated references, subsequent amendments to, or revisions of, this publication do not apply. However, parties to agreements based on this part of ISO 8205 are encouraged to investigate the possibility of applying the most recent edition of the normative document indicated below. For undated references, the latest edition of the normative document referred to applies. Members of ISO and IEC maintain registers of currently valid International Standards.

[ISO 8205-2:2002](#)

ISO 8205-3:1993, *Water-cooled secondary connection cables for resistance welding — Part 3: Test requirements*

3 Term and definition

For the purposes of this part of ISO 8205, the following term and definition apply.

3.1

single-conductor connection cable

cable comprising one conductor providing an electrical link between the secondary terminals of a welding transformer and the welding set (manual or robotized guns)

4 Classification

Single-conductor water-cooled connection cables are classified into two types, C and D, according to the form of the end lugs (see 5.3).

5 Dimensions

5.1 Cross-sectional area

The effective cross-sectional area of copper shall be one of the following (non-preferred values are given in parentheses):

(150 mm²) – 160 mm² – (180 mm²) – 200 mm² – 250 mm² – 315 mm²

5.2 Length

The length, L , of the cable, as shown in Figure 1, shall be one of the following (non-preferred values are given in parentheses):

500 mm – 630 mm – 800 mm – 1 000 mm – 1 250 mm – (1 500 mm) – 1 600 mm – (1 800 mm) – 2 000 mm – (2 240 mm) – 2 500 mm – (2 800 mm) – 3 150 mm – (3 550 mm) – 4 000 mm

The length shall have a tolerance of ${}^{+1}_0$ %.

5.3 End lugs

The end lugs shall have the dimensions given in Figure 1 and Table 1.

iTeh STANDARD PREVIEW
(standards.iteh.ai)

6 Designation

ISO 8205-2:2002
<https://standards.iteh.ai/catalog/standards/sist/936f0bbf-7f1b-4164-aa32-c3d26fb3d8d9/iso-8205-2-2002>

The designation for single-conductor connection cables which comply with the requirements of this part of ISO 8205 shall comprise the following information in the order given:

- the description block (i.e. "single-conductor connection cable");
- reference to this part of ISO 8205, i.e. ISO 8205-2;
- the type of connection cable (i.e. C or D);
- the cross-sectional area of the cable, expressed in square millimetres;
- the length, expressed in millimetres.

EXAMPLE A type C single-conductor connection cable having a cross-sectional area of 200 mm² and a length of 2 500 mm is designated as follows:

Single-conductor connection cable ISO 8205-2 – C – 200 – 2 500

7 Materials

The choice of the materials is at the discretion of the manufacturer. The cable shall be free of silicone.

The insulating covering shall be undamaged. In addition, it shall not contain any components which give off toxic gases on burning and shall withstand a maximum temperature of 100 °C without damage.

Dimensions in millimetres,
surface roughness values in micrometres

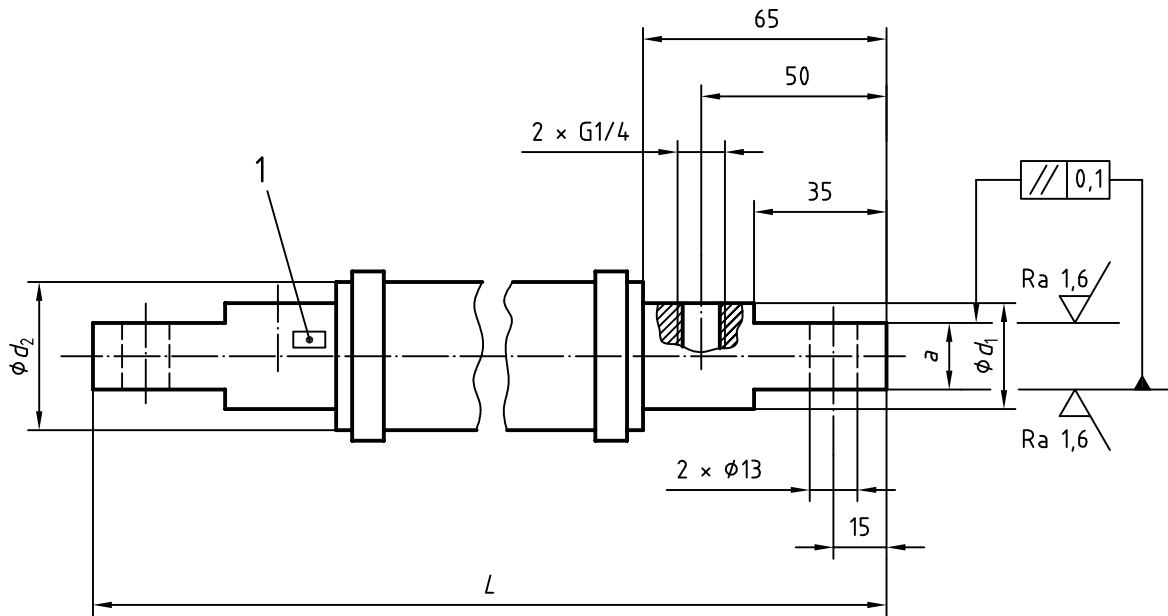

a) Type C

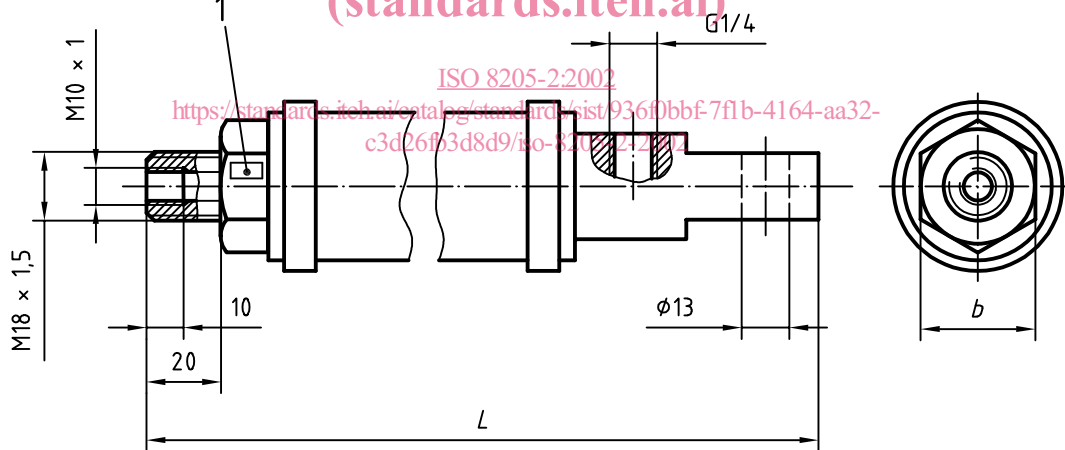

b) Type D

NOTE For dimensions, parallelism tolerances and surface roughness values not shown, see type C.

Key

1 Marking

Figure 1 — End lug

Table 1 — Dimensions

Cross-section area mm ²	<i>a</i> mm	<i>b</i> mm	<i>d</i> ₁ mm	<i>d</i> ₂ mm
(150)	15	27	25	35
160	15	27	25	35
(180)	15	27	25	35
200	15	27	25	35
250	18	30	28	40
315	18	32	32	42

NOTE Non-preferred values are given in parentheses.

8 Requirements

8.1 Electrical characteristics

8.1.1 General

The electrical characteristics are given as theoretical values as a function of cross-sectional areas and lengths. The values are only given to calculate the permissible welding current and the voltage drop in the cable, they are not acceptance figures.

iTeh STANDARD PREVIEW
(standards.iteh.ai)

8.1.2 Permanent current

The values for the permanent current I_{2p} are given in Table 2. The secondary current I_X at a given duty factor X may be calculated from

ISO 8205-2:2002
<https://standards.iteh.ai/catalog/standards/sist/936f0bbf-7fb-4164-aa32-c3d26fb3d8d9/iso-8205-2-2002>

$$I_X = I_{2p} \sqrt{\frac{100}{X}}$$

It shall be taken into consideration that the values shall be reduced if parasitic heating occurs or other influences require it.

8.1.3 Resistance

Resistance values are given in Table 3.

It shall be taken into consideration that, in practice, the values are higher depending on manufacturer and material.

8.2 Mechanical characteristics — Radius of curvature of ends

With the tests carried out as described in 3.3 of ISO 8205-3:1993, the radius of curvature shall be equal or less than 300 mm (in view of the information given in 3.3.3 of ISO 8205-3:1993).

8.3 Cooling

A minimum water flow through the cable of 4 l/min shall be obtained with a maximum pressure differential at the cable ends of 70 kPa (0,7 bar) and with a 300 mm radius of curvature applied at any point along the single-conductor connection cable.

9 Marking

Single-conductor connection cables which comply with the requirements of this part of ISO 8205 shall be marked indelibly on the end lug of one terminal, with the designation stipulated in clause 6, but excluding the description block and the reference to this part of ISO 8205, i. e.

C – 200 – 2 500

The cable shall be clearly marked with the manufacturer's/supplier's name or trademark.

10 Delivery conditions

The cables shall be delivered with suitable protection, particularly to the end lugs and ports of the sealed cooling circuits.

They shall not be packed or supplied in such a manner that the cables are distorted by tight bends or loops lengthwise.

Table 2 — Permanent current I_{2p}

Length mm	Cross-sectional area mm ²					
	(150)	160	(180)	200	250	315
	Permanent current I_{2p} A					
500	13 200	14 000	15 000	16 000	18 000	20 000
630	12 500	12 500	14 000	14 000	16 000	18 000
800	11 200	11 200	12 000	12 500	14 000	16 000
1 000	9 500	10 000	10 600	11 200	12 500	14 000
1 250	8 500	9 000	9 500	10 000	11 200	12 500
(1 500)	8 000	8 500	9 000	9 700	10 800	11 900
1 600	7 500	8 000	8 500	9 000	10 000	11 200
(1 800)	7 100	7 500	8 000	8 500	9 500	10 600
2 000	6 700	7 100	7 500	8 000	9 000	10 000
(2 240)	6 300	6 700	7 100	7 500	8 500	9 500
2 500	6 000	6 300	6 700	7 100	8 000	9 000
(2 800)	5 600	6 000	6 300	6 700	7 600	8 500
3 150	5 300	5 600	6 000	6 300	7 100	8 000
(3 550)	5 000	5 300	5 600	6 000	6 700	7 500
4 000	4 750	5 000	5 300	5 600	6 300	7 100

NOTE 1 Non-preferred values are given in parentheses.

NOTE 2 The values have been calculated with a water flow of 4 l/min with an inlet temperature of 30 °C and an outlet temperature of 70 °C.