

---

---

**Urine-absorbing aids for incontinence —  
Test methods for characterizing  
polymer-based absorbent materials —**

**Part 7:  
Gravimetric determination of absorption  
under pressure**

iTeh STANDARD PREVIEW  
(standards.iteh.ai)

*Aides pour absorption d'urine — Méthodes d'essai pour caractériser les  
matériaux absorbants à base de polymères —*

*Partie 7: Détermination gravimétrique du pouvoir d'absorption sous  
pression*

<https://standards.iteh.ai/catalog/standards/sist/e0e11b54-c3f0-4400-a40f-ee52bfb1240a/iso-17190-7-2001>



**PDF disclaimer**

This PDF file may contain embedded typefaces. In accordance with Adobe's licensing policy, this file may be printed or viewed but shall not be edited unless the typefaces which are embedded are licensed to and installed on the computer performing the editing. In downloading this file, parties accept therein the responsibility of not infringing Adobe's licensing policy. The ISO Central Secretariat accepts no liability in this area.

Adobe is a trademark of Adobe Systems Incorporated.

Details of the software products used to create this PDF file can be found in the General Info relative to the file; the PDF-creation parameters were optimized for printing. Every care has been taken to ensure that the file is suitable for use by ISO member bodies. In the unlikely event that a problem relating to it is found, please inform the Central Secretariat at the address given below.

**iTeh STANDARD PREVIEW**  
**(standards.iteh.ai)**

ISO 17190-7:2001

<https://standards.iteh.ai/catalog/standards/sist/e0e11b54-c3f0-4400-a40f-ee52bfb1240a/iso-17190-7-2001>

© ISO 2001

All rights reserved. Unless otherwise specified, no part of this publication may be reproduced or utilized in any form or by any means, electronic or mechanical, including photocopying and microfilm, without permission in writing from either ISO at the address below or ISO's member body in the country of the requester.

ISO copyright office  
Case postale 56 • CH-1211 Geneva 20  
Tel. + 41 22 749 01 11  
Fax + 41 22 749 09 47  
E-mail [copyright@iso.ch](mailto:copyright@iso.ch)  
Web [www.iso.ch](http://www.iso.ch)

Printed in Switzerland

## Contents

	Page
Foreword.....	iv
Introduction.....	v
1 Scope .....	1
2 Normative references .....	1
3 Principle.....	1
4 Reagents.....	1
5 Apparatus .....	2
6 Sampling.....	3
7 Procedure .....	4
8 Calculation .....	4
9 Precision.....	5
10 Test report .....	5
Annex A (informative) Recommendations for special cases of different cylinder diameters and pressures.....	6
Annex B (informative) Statistical results of interlaboratory tests.....	7

ISO 17190-7:2001

<https://standards.iteh.ai/catalog/standards/sist/e0e11b54-c3f0-4400-a40f-ee52bfb1240a/iso-17190-7-2001>

## Foreword

ISO (the International Organization for Standardization) is a worldwide federation of national standards bodies (ISO member bodies). The work of preparing International Standards is normally carried out through ISO technical committees. Each member body interested in a subject for which a technical committee has been established has the right to be represented on that committee. International organizations, governmental and non-governmental, in liaison with ISO, also take part in the work. ISO collaborates closely with the International Electrotechnical Commission (IEC) on all matters of electrotechnical standardization.

International Standards are drafted in accordance with the rules given in the ISO/IEC Directives, Part 3.

The main task of technical committees is to prepare International Standards. Draft International Standards adopted by the technical committees are circulated to the member bodies for voting. Publication as an International Standard requires approval by at least 75 % of the member bodies casting a vote.

Attention is drawn to the possibility that some of the elements of this part of ISO 17190 may be the subject of patent rights. ISO shall not be held responsible for identifying any or all such patent rights.

International Standard ISO 17190-7 was prepared by Technical Committee ISO/TC 173, *Technical systems and aids for disabled or handicapped persons*, Subcommittee SC 3, *Aids for ostomy and incontinence*.

ISO 17190 consists of the following parts, under the general title *Urine-absorbing aids for incontinence — Test methods for characterizing polymer-based absorbent materials*.

- Part 1: Determination of pH
- Part 2: Determination of amount of residual monomers
- Part 3: Determination of particle size distribution by sieve fractionation
- Part 4: Determination of moisture content by mass loss upon heating
- Part 5: Gravimetric determination of free swell capacity in saline solution
- Part 6: Gravimetric determination of fluid retention capacity in saline solution after centrifugation
- Part 7: Gravimetric determination of absorption under pressure
- Part 8: Gravimetric determination of flowrate
- Part 9: Gravimetric determination of density
- Part 10: Determination of extractable polymer content by potentiometric titration
- Part 11: Determination of content of respirable particles

ISO 17190 is intended to be used in conjunction with ISO 17191, *Urine-absorbing aids for incontinence — Airborne polyacrylate superabsorbent material in the workplace — Determination of the content in respirable dust by sodium atomic absorption spectrometry*.

Annexes A and B of this part of ISO 17190 are given for information only.

## Introduction

ISO 17190 consists of a series of test methods originally developed by *European Disposables and Nonwovens Association (EDANA)*. These test methods have been incorporated without technical changes into one International Standard consisting of eleven parts.

These test methods have been in practical use for several years, and have proven to be reliable with respect to common criteria of quality of test methods (validity, repeatability, etc.). They are applicable to polyacrylate superabsorbent materials, which occur in hygiene products, including urine-absorbing aids for incontinent persons. The test methods are addressed to the *material* exclusively. They are not intended to be used, and are not applicable for use with finished manufactured urine-absorbing aids.

## iTeh STANDARD PREVIEW (standards.iteh.ai)

[ISO 17190-7:2001](https://standards.iteh.ai/catalog/standards/sist/e0e11b54-c3f0-4400-a40f-ee52bfb1240a/iso-17190-7-2001)

<https://standards.iteh.ai/catalog/standards/sist/e0e11b54-c3f0-4400-a40f-ee52bfb1240a/iso-17190-7-2001>

**iTeh STANDARD PREVIEW**  
**(standards.iteh.ai)**

ISO 17190-7:2001

<https://standards.iteh.ai/catalog/standards/sist/e0e11b54-c3f0-4400-a40f-ee52bfb1240a/iso-17190-7-2001>

# Urine-absorbing aids for incontinence — Test methods for characterizing polymer-based absorbent materials —

## Part 7:

### Gravimetric determination of absorption under pressure

#### 1 Scope

This part of ISO 17190 specifies a method for determining the capacity of polyacrylate (PA) superabsorbent powders to absorb saline solution under a specified pressure.

This method is applicable to materials having maximum 0,1 % of the particle size distribution below 45 µm.

#### 2 Normative references

The following normative documents contain provisions which, through reference in this text, constitute provisions of this part of ISO 17190. For dated references, subsequent amendments to, or revisions of, any of these publications do not apply. However, parties to agreements based on this part of ISO 17190 are encouraged to investigate the possibility of applying the most recent editions of the normative documents indicated below. For undated references, the latest edition of the normative document referred to applies. Members of ISO and IEC maintain registers of currently valid International Standards.

ISO 187, *Paper, board and pulps — Standard atmosphere for conditioning and testing and procedure for monitoring the atmosphere and conditioning of samples*

ISO 3696, *Water for analytical laboratory use — Specification and test methods*

ISO 5725-2, *Accuracy (trueness and precision) of measurement methods and results — Part 2: Basic method for the determination of repeatability and reproducibility of a standard measurement method*

#### 3 Principle

The test portion is weighed and spread on the bottom filter screen closing a specified cylinder. A uniform pressure is first applied to the test portion. The cylinder then is placed on a filter plate which is placed in a petri dish filled with saline solution. After an absorption contact time of 1 h, the cylinder is removed from the filter plate and weighed to determine the amount of fluid absorbed.

#### 4 Reagents

Use only reagents of recognized analytical grade, unless otherwise specified.

**4.1 Water**, complying with ISO 3696.

**4.2 Sodium chloride solution**,  $c(\text{NaCl}) = 0,9 \%$  by mass.

Weigh, to the nearest 0,1 g, 9 g of sodium chloride into a 1 l volumetric flask (5.4) and make up to the mark with deionized water (grade 3, see 4.1). Stir until dissolved.

## 5 Apparatus

**5.1 Apparatus for measuring absorbency under pressure**, shown in Figure 1, and consisting of the following elements:

- 5.1.1 Petri dish or tray**, of which the bottom surface area is 400 cm<sup>2</sup> per test apparatus.
- 5.1.2 Filter plate**, in ceramic for a filter diameter of 120 mm, of porosity = 0 and at least 5 mm in height.
- 5.1.3 Filter paper**, having a diameter between 70 mm and 120 mm with pore size < 25 µm.
- 5.1.4 Plexiglas cylinder**, having an internal diameter of  $d_1 = (60 \pm 0,2)$  mm, a height equal to  $(50 \pm 0,5)$  mm, with a nylon cloth filter screen or stainless steel filter screen in the bottom (400 mesh = 36 µm).

For different diameters see annex A.

**5.1.5 Plastic piston**, with a **cylindrical weight**, of which the total mass is equal to  $(574 \pm 5)$  g, corresponding to a surface density of  $(21 \pm 0,2)$  g/cm<sup>2</sup>.

The piston diameter,  $d_2$ , is such that  $d_1 - d_2 = (0,8 \pm 0,2)$  mm and the height of the cylindrical weight is  $(60 \pm 0,5)$  mm.

**5.2 Analytical balance**, capable of weighing, to the nearest 0,001 g, masses up to 500 g.

**5.3 Timer**, accurate to 1 s over 1 h.

**5.4 Volumetric flask**, Grade A of 1 l capacity. [ISO 17190-7:2001](#)

<https://standards.iteh.ai/catalog/standards/sist/e0e11b54-c3f0-4400-a40f-ee52bfb1240a/iso-17190-7-2001>

iTeh STANDARD PREVIEW  
(standards.iteh.ai)

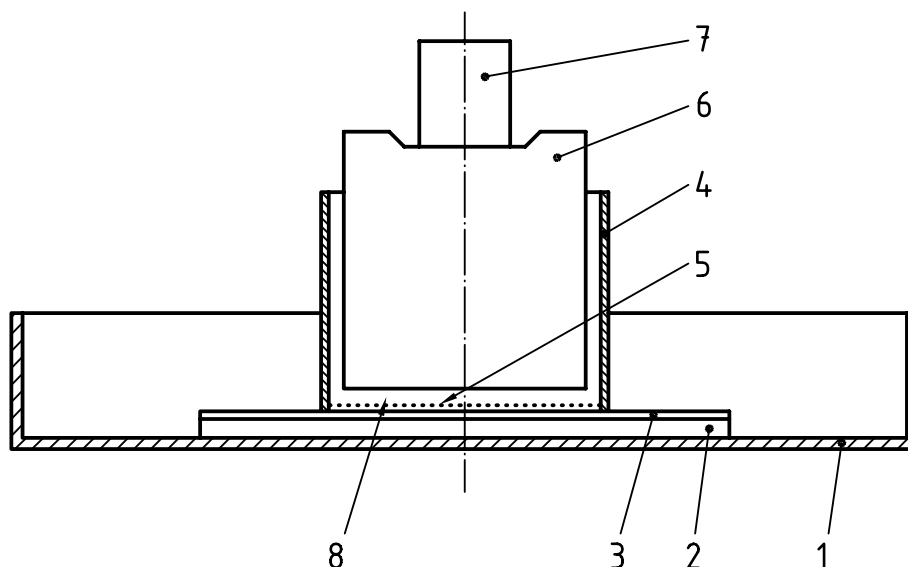

**Key**

- 1 Petri dish (or tray)
- 2 Filter plate
- 3 Filter paper
- 4 Plexiglass cylinder
- 5 Screen
- 6 Plastic piston
- 7 Cylindrical weight
- 8 Test portion

**iTeh STANDARD PREVIEW**  
(standards.iteh.ai)

ISO 17190-7:2001

Figure 1 — Apparatus for measuring absorbency, under pressure, of PA superabsorbent powders

## 6 Sampling

**CAUTION** — Use respiratory protection, dust mask or fume hood, when handling sample amounts greater than 10 g.

In order to guarantee that a representative sample is taken from the bulk material contained in a large bag or a silo truck, remove the top layer (approximately 20 cm). Take the test sample with a scoop. Place it in an airtight container of adequate size within 3 min after sampling.

Keep the test samples in a closed container and allow them to equilibrate to the ambient laboratory temperature before removing a test portion to run the test. The preferred test conditions are  $(23 \pm 2) ^\circ\text{C}$  and  $(50 \pm 10) \%$  relative humidity. If these conditions are not available, test at ambient conditions and report the temperature and relative humidity. Measure these laboratory conditions in accordance with ISO 187.

Before taking a test portion out of the container to run the test, rotate the container three to five times so as to obtain a homogeneous product. Allow the container to sit 5 min before opening the lid and removing the test portion.

Make sure the test portion is substantially free of lumps of size greater than 1 mm in diameter before proceeding with testing.