Radijska oprema za digitalno povezavo VHF (VDL) zrak-tla in zrak-zrak, 4. način - Tehnične karakteristike in merilne metode za aeronavtično mobilno (letalsko) opremo - 3. del: Dodatni vidiki v zvezi z radiodifuzijo

VHF air-ground and air-air Digital Link (VDL) Mode 4 radio equipment - Technical characteristics and methods of measurement for aeronautical mobile (airborne) equipment - Part 3: Additional broadcast aspects

iTeh STANDARD PREVIEW
(standards.iteh.ai)

[SIST EN 302 842-3 V1.3.1:2011
https://standards.iteh.ai/catalog/standards/sist/73d7481a-f939-45d3-9527-10f723ff51eb/sist-en-302-842-3-v1-3-1-2011](https://standards.iteh.ai/catalog/standards/sist/73d7481a-f939-45d3-9527-10f723ff51eb/sist-en-302-842-3-v1-3-1-2011)

Ta slovenski standard je istoveten z: EN 302 842-3 Version 1.3.1

ICS:

33.060.99	Druga oprema za radijske komunikacije	Other equipment for radiocommunications
49.090	Oprema in instrumenti v zračnih in vesoljskih plovilih	On-board equipment and instruments

SIST EN 302 842-3 V1.3.1:2011 **en**

iTeh STANDARD PREVIEW
(standards.iteh.ai)

SIST EN 302 842-3 V1.3.1:2011

<https://standards.iteh.ai/catalog/standards/sist/73d7481a-f939-45d3-9527-10f723ff51eb/sist-en-302-842-3-v1-3-1-2011>

ETSI EN 302 842-3 V1.3.1 (2011-09)



**VHF air-ground and air-air Digital Link (VDL)
Mode 4 radio equipment;
Technical characteristics and methods of measurement
for aeronautical mobile (airborne) equipment;
Part 3: Additional broadcast aspects**

STANDARD PREVIEW
(standard link)
SIST EN 302 842-3 V1.3.1:2011
10f723ff51eb/sist-en-302-842-3-v1-3-1-2011

Reference

REN/AERO-00007-3

Keywords

aeronautical, digital, radio, testing, VHF

ETSI

650 Route des Lucioles
F-06921 Sophia Antipolis Cedex - FRANCE

Tel.: +33 4 92 94 42 00 Fax: +33 4 93 65 47 16

Siret N° 348 623 562 00017 - NAF 742 C
Association à but non lucratif enregistrée à la
Sous-Préfecture de Grasse (06) N° 7803/88

iTeh STANDARD PREVIEW
(standards.iteh.ai)

SIST EN 302 842-3 V1.3.1:2011

<https://standards.iteh.ai/catalog/standards/sist/73d7481a-f939-45d3-9527-10f723ff51c7/sist-302-842-3-v1-3-1-2011>

Important notice

Individual copies of the present document can be downloaded from:

<http://www.etsi.org>

The present document may be made available in more than one electronic version or in print. In any case of existing or perceived difference in contents between such versions, the reference version is the Portable Document Format (PDF). In case of dispute, the reference shall be the printing on ETSI printers of the PDF version kept on a specific network drive within ETSI Secretariat.

Users of the present document should be aware that the document may be subject to revision or change of status. Information on the current status of this and other ETSI documents is available at

<http://portal.etsi.org/tb/status/status.asp>

If you find errors in the present document, please send your comment to one of the following services:

http://portal.etsi.org/chaicor/ETSI_support.asp

Copyright Notification

No part may be reproduced except as authorized by written permission.
The copyright and the foregoing restriction extend to reproduction in all media.

© European Telecommunications Standards Institute 2011.
All rights reserved.

DECT™, **PLUGTESTS™**, **UMTS™** and the ETSI logo are Trade Marks of ETSI registered for the benefit of its Members.
3GPP™ and **LTE™** are Trade Marks of ETSI registered for the benefit of its Members and of the 3GPP Organizational Partners.
GSM® and the GSM logo are Trade Marks registered and owned by the GSM Association.

Contents

Intellectual Property Rights	5
Foreword.....	5
Introduction	6
1 Scope	7
2 References	8
2.1 Normative references	8
2.2 Informative references.....	9
3 Definitions and abbreviations.....	9
3.1 Definitions.....	9
3.1.1 Basic reference model definitions.....	9
3.1.2 Service conventions definitions	9
3.1.3 General definitions.....	10
3.1.4 Definition of bit order.....	10
3.2 Abbreviations	10
4 General description of VDL Mode 4 broadcast services.....	12
4.1 General	12
4.2 Automatic Dependent Surveillance-Broadcast (ADS-B)	12
4.3 Traffic Information Service-Broadcast (TIS-B)	13
4.4 Flight Information Service-Broadcast (FIS-B)	14
4.5 GNSS Augmentation Service-Broadcast (GNS-B)	15
5 Minimum performance specification under standard test conditions.....	16
5.1 Requirements for ADS-B	16
5.1.1 Information Field Formats	16
5.1.2 ADS-B Request	26
5.1.2.1 ADS-B request format	26
5.1.2.2 Sleep Mode	26
5.1.2.3 Automatic Selection of Variable Information Fields	27
5.1.3 Default ADS-B Reporting	29
5.1.4 ADS-B Procedures.....	29
5.1.5 CTRL Parameters	31
5.1.5.1 Directory of Service (DOS) message	31
5.1.5.2 Channel Management Parameter	32
5.1.6 Definitions for Compact Position Reporting	42
5.1.6.1 Information Field Offset Encoding	42
5.1.6.2 Information Field Offset Decoding.....	44
5.1.6.3 Patch ID Encoding	45
5.1.6.4 Patch Id Decoding.....	45
5.1.7 Encoding of UDATA (udid)	46
5.2 Requirements for TIS-B	46
5.2.1 Traffic Information Volume (TIV)	46
5.2.2 Void.....	47
5.2.3 Message format.....	47
5.2.4 Management message	48
5.2.5 Aircraft target messages (airborne TIV).....	49
5.2.6 Aircraft target messages (ground TIV).....	51
5.2.7 Ground vehicle target messages (ground TIV).....	52
5.2.8 TIS-B offset encoding.....	53
5.3 Requirements for FIS-B	56
5.3.1 Message format for received FIS-B messages.....	56
5.3.2 Meteorological Aerodrome Report (METAR) message	57
5.3.3 Special Observations and Reports (SPECI) message.....	64
5.3.4 Automatic Terminal Information Service (ATIS) message	65
5.3.5 Runway Condition (RCN) message.....	67

5.3.6	SIGNificant METEorological Information (SIGMET) message.....	71
5.3.7	Temporary Segregated Areas (TSA) message	72
5.3.8	FIS-B report request message	75
5.3.9	Void	76
5.3.9a	Airborne system functions	76
5.3.9a.1	Transmission of requests	76
5.3.9a.2	Differentiation between reports.....	76
5.4	Requirements for GNSS Augmentation Service Broadcast (GNS-B) message	77
5.4.1	Message format.....	77
5.4.2	Message Type 1	78
5.4.3	Message Type 2	81
5.4.4	Message Type 4	84
5.4.5	CRC Calculation.....	90
5.4.5.1	GNS-B CRC.....	90
5.4.5.2	FAS CRC	90
5.4.5.3	Ephemeris CRC.....	91
6	General design requirements	91
7	Protocol test procedures	91
7.1	General	91
7.2	Required test rig	92
7.3	Protocol test-suite description methodology	92
7.4	Detailed protocol test procedures	92
7.4.1	Test-suite overview	92
7.4.2	Declarations	95
7.4.3	Constraints	96
7.4.3.1	Abbreviations.....	96
7.4.3.1.1	Subfield mnemonics	96
7.4.3.1.2	Station addresses and positions	99
7.4.3.1.3	Tables of values for use in CPR test cases	100
7.4.3.1.4	Tables of values for use in content checking test cases	110
7.4.3.1.5	VDL4 Burst formats	144
7.4.3.2	Test cases	179
7.4.3.2.1	Test case macros	180
7.4.3.2.2	Test case descriptions	181
Annex A (informative):	Cross reference matrix	260
Annex B (informative):	Bibliography	270
History		277

Intellectual Property Rights

IPRs essential or potentially essential to the present document may have been declared to ETSI. The information pertaining to these essential IPRs, if any, is publicly available for **ETSI members and non-members**, and can be found in ETSI SR 000 314: "*Intellectual Property Rights (IPRs); Essential, or potentially Essential, IPRs notified to ETSI in respect of ETSI standards*", which is available from the ETSI Secretariat. Latest updates are available on the ETSI Web server (<http://ipr.etsi.org>).

Pursuant to the ETSI IPR Policy, no investigation, including IPR searches, has been carried out by ETSI. No guarantee can be given as to the existence of other IPRs not referenced in ETSI SR 000 314 (or the updates on the ETSI Web server) which are, or may be, or may become, essential to the present document.

Foreword

This European Standard (EN) has been produced by ETSI Technical Committee Aeronautics (AERO).

The present document is part 3 of a multi-part deliverable covering the VHF air-ground and air-air Digital Link (VDL) Mode 4 radio equipment; Technical characteristics and methods of measurement for aeronautical mobile (airborne) equipment, as identified below:

Part 1: "Physical layer";

Part 2: "General description and data link layer";

Part 3: "Additional broadcast aspects";

Part 4: "Point-to-point functions". (standards.iteh.ai)

The present document is accompanied by an equivalent ground-based standard, EN 301 842 [4], [5], [6] and [7], parts 1 to 4 covering the VHF air-ground Data Link (VDL) Mode 4 radio equipment; Technical characteristics and methods of measurement for ground-based equipment.

NOTE 1: Minimum Operational Performance Specifications (MOPS) are also being developed for VDL Mode 4. EUROCAE have previously published Interim MOPS for VDL Mode 4 [i.6] which are a sub set of EN 302 842-1 [1], EN 302 842-2 [2], EN 302 842-3 (the present document) and EN 302 842-4 [3]. EN 302 842-1 [1], EN 302 842-2 [2], EN 302 842-3 (the present document) and EN 302 842-4 [3] comply with the requirements of CEC Mandate M/318.

NOTE 2: Following the decision taken at the ICAO Aeronautical Communication Panel's WG/M (Bangkok, February 2011), it remains to be seen if ICAO Annex 10 Vol III will be amended changing the recommended tuning frequency range from 108-117,975 MHz to 112-117,975 MHz. The present document will be updated accordingly if the amendment is accepted and made publicly available.

National transposition dates

Date of adoption of this EN:	20 September 2011
Date of latest announcement of this EN (doa):	31 December 2011
Date of latest publication of new National Standard or endorsement of this EN (dop/e):	30 June 2012
Date of withdrawal of any conflicting National Standard (dow):	30 June 2012

Introduction

The present document states the technical specifications for Very High Frequency (VHF) Digital Link (VDL) Mode 4 aeronautical mobile (airborne) radio transmitters, transceivers and receivers for air-ground and air-air communications operating in the VHF band, using Gaussian Filtered Frequency Shift Keying (GFSK) modulation with 25 kHz channel spacing and capable of tuning to any of the 25 kHz channels from 118,000 MHz to 136,975 MHz as defined in ICAO VDL SARPs [i.2].

The present document may be used to produce tests for the assessment of the performance of the equipment. The performance of the equipment submitted for type testing should be representative of the performance of the corresponding production model.

The present document has been written on the assumption that:

- the type test measurements will be performed only once, in an accredited test laboratory and the measurements accepted by the various authorities in order to grant type approval;
- if equipment available on the market is required to be checked it will be tested in accordance with the methods of measurement specified in the present document or a documented alternative approved by the certifying authority;
- equipment comply with EN 302 842-1 [1] and EN 302 842-2 [2].

NOTE: The present document has been produced with a view to maintaining consistency of numbering with the equivalent standard for ground equipment (EN 301 842 [4], [5], [6] and [7]). Where requirements are the same, they have been given the same number. Some new airborne requirements have been inserted between requirements that were sequential in EN 301 842 [4], [5], [6] and [7]. This has led to a non-standard form of numbering for new requirements in some places.

(standards.iteh.ai)

[SIST EN 302 842-3 V1.3.1:2011](https://standards.iteh.ai/catalog/standards/sist/73d7481a-f939-45d3-9527-10f723ff51eb/sist-en-302-842-3-v1-3-1-2011)

<https://standards.iteh.ai/catalog/standards/sist/73d7481a-f939-45d3-9527-10f723ff51eb/sist-en-302-842-3-v1-3-1-2011>

1 Scope

The present document applies to the following radio equipment types:

- Very High Frequency (VHF) Digital Link (VDL) Mode 4 aeronautical mobile (airborne) radio transmitters, transceivers and receivers for air-ground and air-air communications operating in the VHF band, using Gaussian Filtered Frequency Shift Keying (GFSK) modulation with 25 kHz channel spacing and capable of tuning to any of the 25 kHz channels from 118,000 MHz to 136,975 MHz as defined in ICAO VDL SARPs 130 [i.2].

The present technical document provides part 3 of the technical specifications.

The present document is designed to ensure that equipment certified to it will be compatible with the relevant ICAO VDL SARPs [i.2] and ICAO VDL4 Technical Manual [i.1].

Manufacturers should note that in future the tuning range for the transmitter may also cover any 25 kHz channel from 112,000 MHz to 117,975 MHz and the receiver(s) may cover any 25 kHz channel from 108,000 MHz to 117,975 MHz.

The present document applies to "aeronautical mobile (airborne and in some cases ground vehicles)" equipment which will hereinafter be referred to as "mobile" equipment.

The scope of the present document is limited to mobile stations. The equivalent specification for ground stations is EN 301 842 [4], [5], [6] and [7].

A description of the scope of the VDL Mode 4 system is provided in part 2 of these technical specifications (see EN 302 842-2 [2], clause 1).

EN 302 842-1 [1] deals with tests of the physical layer. EN 302 842-2 [2] deals with tests of the link layer sufficient to support broadcast functionality including requirements and tests sufficient to recognize and respond to transmissions associated with point-to-point communication. The present document provides technical specifications for a VDL Mode 4 mobile transceiver supporting a full Automatic Dependent Surveillance-Broadcast (ADS-B) capability and, optionally, the additional functionality of either, or a combination of, the following services:

- Traffic Information Service-Broadcast (TIS-B);
- Flight Information Service-Broadcast (FIS-B);
- GNSS Augmentation Service-Broadcast (GNS-B).

The TIS-B, FIS-B, or GNS-B reception processing functionality in the airborne equipment is expected to be provided by a TIS-B, FIS-B or GNS-B processor, which could be contained within the VDL Mode 4 transceiver, but could also be housed in a separate physical unit. Therefore to support TIS-B, FIS-B or GNS-B message reception, the minimum functionality demanded of a basic VDL Mode 4 airborne transceiver unit (i.e. one that does not have a TIS-B, FIS-B or GNS-B processor housed within it) is to pass to the TIS-B, FIS-B or GNS-B processor, all TIS-B, FIS-B or GNS-B messages received.

As the measured values of equipment performance may be a function of the method of measurement, standard test conditions and methods of test are recommended in the present document.

The present document is organized as follows:

- clause 2 provides references to relevant documents;
- clause 3 provides general definitions, abbreviations and symbols used;
- clause 4 describes the VDL Mode 4 mobile station functionality to support ADS-B, TIS-B, FIS-B and GNS-B;
- clause 5 provides performance specifications for the VDL Mode 4 mobile station supporting ADS-B, TIS-B, FIS-B and GNS-B Services;
- clause 6 provides general design requirements;

- clause 7 provides protocol tests which emphasis the ADS-B, TIS-B, FIS-B and GNS-B functions of the system;
- annex A provides a detailed cross-reference to the relevant requirements contained in ICAO VDL4 Technical Manual [i.1];
- annex B provides a Bibliography;
- a document history.

Note that the system can support a very wide range of functions. It is not practical to provide specific tests for all aspects of functionality. The approach used is to provide detailed tests for the core functionality to support ADS-B, FIS-B, TIS-B and GNS-B focusing on the system requirements which, if wrongly implemented, could cause a deterioration in the service offered by other VDL Mode 4 stations.

Mandating and Recommendation Phrases

- a) "Shall":
- The use of the word "Shall" indicates a mandated criterion; i.e. compliance with the particular procedure or specification is mandatory and no alternative may be applied.
- b) "Should":
- The use of the word "Should" (and phrases such as "It is recommended that...", etc.) indicates that though the procedure or criterion is regarded as the preferred option, alternative procedures, specifications or criteria may be applied, provided that the manufacturer, installer or tester can provide information or data to adequately support and justify the alternative.

iTeh STANDARD PREVIEW

2 References (standards.iteh.ai)

References are either specific (identified by date of publication and/or edition number or version number) or non-specific. For specific references, only the cited version applies. For non-specific references, the latest version of the referenced document (including any amendments) applies.

Referenced documents which are not found to be publicly available in the expected location might be found at <http://docbox.etsi.org/Reference>.

NOTE: While any hyperlinks included in this clause were valid at the time of publication ETSI cannot guarantee their long term validity.

2.1 Normative references

The following referenced documents are necessary for the application of the present document.

- [1] ETSI EN 302 842-1 (V1.2.3): "VHF air-ground and air-air Digital Link (VDL) Mode 4 radio equipment; Technical characteristics and methods of measurement for aeronautical mobile (airborne) equipment; Part 1: Physical layer".
- [2] ETSI EN 302 842-2 (V1.3.1): "VHF air-ground and air-air Digital Link (VDL) Mode 4 radio equipment; Technical characteristics and methods of measurement for aeronautical mobile (airborne) equipment; Part 2: General description and data link layer".
- [3] ETSI EN 302 842-4 (V1.2.2): "VHF air-ground and air-air Digital Link (VDL) Mode 4 radio equipment; Technical characteristics and methods of measurement for aeronautical mobile (airborne) equipment; Part 4: Point-to-point functions".
- [4] ETSI EN 301 842-1 (V1.3.3): "VHF air-ground Digital Link (VDL) Mode 4 radio equipment; Technical characteristics and methods of measurement for ground-based equipment; Part 1: EN for ground equipment".

- [5] ETSI EN 301 842-2 (V1.6.1): "VHF air-ground Digital Link (VDL) Mode 4 radio equipment; Technical characteristics and methods of measurement for ground-based equipment; Part 2: General description and data link layer".
- [6] ETSI EN 301 842-3 (V1.3.1): "VHF air-ground and air-air Digital Link (VDL) Mode 4 radio equipment; Technical characteristics and methods of measurement for aeronautical mobile (airborne) equipment; Part 3: Additional broadcast aspects".
- [7] ETSI EN 301 842-4 (V1.2.2): "VHF air-ground Digital Link (VDL) Mode 4 radio equipment; Technical characteristics and methods of measurement for ground-based equipment; Part 4: Point-to-point functions".

2.2 Informative references

The following referenced documents are not necessary for the application of the present document but they assist the user with regard to a particular subject area.

- [i.1] ICAO Doc 9816 (First Edition 2004): "Manual on VHF Digital Link (VDL) Mode 4 - Part 2: Detailed Technical Specifications".
- [i.2] ICAO Annex 10 to the Convention on International Civil Aviation: "Aeronautical Telecommunications, Volume III: Communication Systems, Part I: Digital Data Communication Systems, chapter 6".
- [i.3] RTCA DO-242A: "Minimum Aviation System Performance Standards for Automatic Dependent Surveillance Broadcast (ADS-B)".
- [i.4] Amendments 76 and 77 to Volume I of Annex 10 to the Convention on International Civil Aviation, International Civil Aviation Organization: Appendix B-B2, 3.6 "Ground-based augmentation system (GBAS)".

NOTE: <http://www.icao.int>.

- [i.5] EUROCAE ED-114: "Minimum Operational Performance Specification for Global Navigation Satellite Ground Based Augmentation System Ground Equipment to Support Category I Operations".

NOTE: <http://www.eurocae.net>.

- [i.6] EUROCAE ED-108A: "MOPS for VDL Mode 4 Aircraft Transceiver for ADS-B", July 2001.

3 Definitions and abbreviations

3.1 Definitions

3.1.1 Basic reference model definitions

See EN 302 842-2 [2], clause 3.1.1.

3.1.2 Service conventions definitions

See EN 302 842-2 [2], clause 3.1.2.

3.1.3 General definitions

For the purposes of the present document, the terms and definitions given in EN 302 842-1 [1], clause 3.1.3, EN 302 842-2 [2], clause 3.1.3 and the following apply:

Automatic Dependent Surveillance-Broadcast (ADS-B): surveillance application transmitting parameters, such as position, track, ground speed and time via a broadcast mode data link for use by any air and ground users requiring it

NOTE: ADS-B is a surveillance service based on aircraft self-determination of position/velocity/time and automatic, periodic, broadcast of this information along with auxiliary data such as aircraft identity (ID), intent information and communications control parameters, etc. ADS-B is intended to support multiple high-level applications and associated services such as cockpit display of traffic information, traffic alert and collision avoidance functionality, enhanced traffic management in the air and on the ground, search and rescue support and others.

Automatic Terminal Information Service (ATIS): report generated by a ground station that includes weather conditions, operating procedures, runways and approaches in use, and any other information that may affect the departure, runway and landing phase of flight

Flight Information Service-Broadcast (FIS-B): uplink broadcast application providing local airborne traffic with information

GNSS augmentation Service-Broadcast (GNS-B): uplink broadcast application providing aircraft with GNSS augmentation and integrity data

METeorological Aerodrome Report (METAR): report generated by a ground station that broadcasts meteorological conditions at aerodromes, officially recoded and communicated at regular intervals

SIGNificant METeorological Information (SIGMET): report generated by a ground station that broadcasts information about weather phenomena that may have an impact on aircraft at subsonic, transonic and supersonic cruising levels including thunderstorms, cyclones, turbulence and icing

SPECIAL observations and reports (SPECI): report generated by a ground station that is issued when meteorological conditions change sufficiently to affect aviation operations

NOTE: The SPECI report contains the same information as a METAR.

Traffic Information Service-Broadcast (TIS-B): uplink surveillance service that derives traffic information from one or more ground surveillance sources and broadcasts that information to suitably equipped aircraft or surface vehicles

Traffic Information Volume (TIV): volume of airspace for which surveillance information is provided for all targets

NOTE: Inside the TIV, a pilot knows he can rely on the surveillance picture presented to him; outside the TIV, ADS-B reports may be received but TIS-B reports may not be available.

3.1.4 Definition of bit order

In the tables included in the present document to illustrate the format of bursts, the following order is implied:

- a) bit order in each burst subfield shall be indicated by subscript numbers. Bit 1 shall indicate the least significant bit; and
- b) bits shall be transmitted octet by octet, starting with the first octet in each table, and within each octet the rightmost bit (as shown in the tables) shall be transmitted first.

3.2 Abbreviations

For the purposes of the present document, the following abbreviations apply:

ADS-B	Automatic Dependent Surveillance-Broadcast
ATIS	Automatic Terminal Information Service
CCI	Co-Channel Interference
CPR	Compact Position Reporting

CRC	Cyclic Redundancy Code
dB	deciBel
DLPDU	Data Link Protocol Data Unit
DLS	Data Link Service
DOS	Directory Of Services
EUROCAE	EUROpean Organization for Civil Aviation Equipment
FAS	Final Approach Segment
FIS-B	Flight Information Service-Broadcast
FPAP	Flight Path Alignment Point
fpm	feet per minute
fps	feet per second
FTP	Fictitious Threshold Point
GBAS	Ground-Based Augmentation System
GCID	GNS-B Continuity / Integrity Designator
GFSK	Gaussian Filtered Frequency Shift Keying
GLONASS	GLOBAL NAVigation Satellite System (Russian system)
GNS-B	GNSS augmentation Service-Broadcast
GNSS	Global Navigation Satellite System
GPA	Glide Path Angle
GPS	Global Positioning System
GRAS	Ground-based Regional Augmentation System
GSC	Global Signalling Channel
hex	hexadecimal
IA-5	International Alphabet-5
ICAO	International Civil Aviation Organization
ID	IDentity
INFO	INFORMATION (DLPDU)
LTP	Landing Threshold Point
MASPS	Minimum Aviation System Performance Standards
MEDUP	MEDiterranean Update Programme
METAR	METEorological Aerodrome Report
MOPS	Minimum Operational Performance Specification
ms	milliseconds
NEAN	North European ADS-B Network
NM	Nautical Mile
NUP	NEAN Update Programme
PCO	Point of Control and Observation
PRN	Pseudo Random Noise
RCN	Runway Condition
RF	Radio Frequency
SARPs	Standards And Recommended Practices
SBAS	Space-Based Augmentation System
SIGMET	SIGNificant METEorological information
SPECI	SPECIAL observations and reports
SVQ	State Vector Quality
TCH	Threshold Crossing Height
TCP	Trajectory Change Point
TIS-B	Traffic Information Service-Broadcast
TIV	Traffic Information Volume
TSA	Temporary Segregated Areas
TV	Transmission Volume
UTC	Universal Time Coordinated
VDL	VHF Digital Link
VHF	Very High Frequency
VSS	VDL Mode 4 Specific Services

4 General description of VDL Mode 4 broadcast services

4.1 General

A description of VDL Mode 4 is provided in clause 4.1 of EN 302 842-2 [2]. This clause provides a description of the assumptions made in the derivation of the requirements for the VDL Mode 4 mobile station.

In most respects, the VDL Mode 4 mobile station follows the provisions of the ICAO standards material for VDL Mode 4. Within the ICAO standard, there are some requirements that apply explicitly only to ground stations. A number of other requirements will also not apply because of the assumed services provided by the mobile station. The assumed services provided by the mobile station and the impact on the requirements are summarized in the rest of clause 4.

The scope of the present document is for a mobile station supporting broadcast applications. Hence the ability to support point-to-point communication is not included in the present document. Those requirements are presented in EN 302 842-4 [3].

Note that, although certain protocols will not be used by the mobile station, the ability to recognize the use by mobiles of these protocols and to respond in a consistent manner is a mobile station requirement and is included in the present document.

4.2 Automatic Dependent Surveillance-Broadcast (ADS-B)

Automatic Dependent Surveillance-Broadcast (ADS-B) is a surveillance application in which aircraft, vehicles and ground stations broadcast their identity, position, velocity, time, intent and other information, enabling other aircraft, vehicles and ground stations to develop a surveillance picture.

ADS-B relies on the regular and frequent transmission of position reports via a broadcast data link. The position reports are sent periodically by the aircraft with no intervention from the ground. Position reports may be received by any recipient in range of the transmitting aircraft. Recipients may be other aircraft, ground vehicles or fixed ground sites.

ADS-B offers data delivery from aircraft-to-aircraft or from aircraft-to-ground. Transmitting data directly from air-to-air means that there is no need for a ground infrastructure to be present for airborne surveillance to be performed. By using position reports received from surrounding aircraft, a traffic surveillance picture can be generated in the cockpits of all of the aircraft. This potentially allows new applications or new manoeuvres to be performed by pilots.

The transmitting aircraft does not know which, if any, recipients are receiving and processing the position reports. Unlike a point-to-point link, position reports are not acknowledged. The concept with ADS-B is that position reports are transmitted so frequently that the loss of a small number of position reports is not operationally significant.

ADS-B messages are broadcast and received by appropriately equipped participant subsystems. ADS-B subsystems include aircraft, vehicles and ground subsystems. The capabilities of participant subsystems will vary based upon class of equipment. The ADS-B aircraft subsystem interacts with other onboard systems such as pilot display equipment and the aircraft navigation system. The ADS-B ground subsystem interacts with other ground systems such as ATM applications and controller display processing equipment.

If received by a data acquisition unit, the position report will be processed with other surveillance data and may be forwarded to a controller/pilot display.

Airborne VDL Mode 4 stations supporting full ADS-B capability:

- Receive and process the ADS-B reports from other aircraft, vehicles and ground stations, passing the received data to a surveillance server.
- Transmit ADS-B reports at the required regular intervals (or more frequently) and including required and possibly some optional information.

Figure 4.1 illustrates the context for the airborne station supporting ADS-B functions.

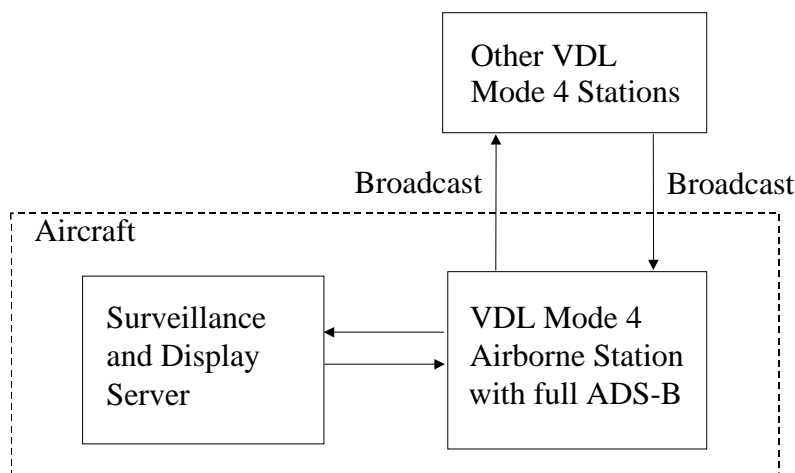

Figure 4.1: Airborne station supporting ADS-B functions

A VDL Mode 4 airborne station supporting ADS-B receives broadcast ADS-B reports and passes on the data to a surveillance processor. A VDL Mode 4 airborne station supporting ADS-B may also receive data for transmission and instructions for transmission rates from the surveillance processor.

The requirements for ADS-B are taken from the ICAO VDL 4 Technical Manual [i.1].

4.3 Traffic Information Service-Broadcast (TIS-B)

Traffic Information Service-Broadcast (TIS-B) is a surveillance service that derives traffic information from one or more ground surveillance sources and broadcasts that information to suitably equipped aircraft or surface vehicles.

The purpose of TIS-B is to complement the surveillance information provided from ADS-B aircraft to ensure that a full surveillance picture is available to airborne systems.

The TIS-B service is provided within an area known as the Traffic Information Volume (TIV), which is the volume of airspace for which surveillance information is provided for all targets. Inside the TIV, a pilot knows he can rely on the surveillance picture presented to him; outside the TIV, ADS-B reports may be received but TIS-B reports may not be available.

A TIS-B service either provides a "full surveillance picture" or a "gap filler service". For the full surveillance picture, information is provided on all targets. The "gap filler service" information is only provided for targets which do not support ADS-B via VDL Mode 4.

A VDL Mode 4 airborne station supporting TIS-B receives two main sorts of message:

- a) Management Messages: which contain information about the TIS-B service and the TIV.
- b) Target Messages: which contain information about aircraft or ground vehicle targets.