



Designation: D 746 – 04

Standard Test Method for Brittleness Temperature of Plastics and Elastomers by Impact¹

This standard is issued under the fixed designation D 746; the number immediately following the designation indicates the year of original adoption or, in the case of revision, the year of last revision. A number in parentheses indicates the year of last reapproval. A superscript epsilon (ϵ) indicates an editorial change since the last revision or reapproval.

1. Scope*

1.1 This test method covers the determination of the temperature at which plastics and elastomers exhibit brittle failure under specified impact conditions. Two routine inspection and acceptance procedures are also provided.

NOTE 1—When testing rubbers for impact brittleness use Test Methods D 2137.

1.2 The values stated in SI units are to be regarded as the standard.

1.3 *This standard does not purport to address all of the safety concerns, if any, associated with its use. It is the responsibility of the user of this standard to establish appropriate safety and health practices and determine the applicability of regulatory limitations prior to use.*

NOTE 2—This test method and ISO 974–2000 (E) are technically equivalent when using the Type B fixture and the Type III specimen, however, the minimum number of specimens that are required to be tested is significantly different when using this test method. The ISO method requires that a minimum of 100 specimens be tested.

2. Referenced Documents

2.1 ASTM Standards:²

- D 618 Practice for Conditioning Plastics for Testing
- D 832 Practice for Rubber Conditioning for Low-Temperature Testing
- D 883 Terminology Relating to Plastics
- D 2137 Test Methods for Rubber Property—Brittleness Point of Flexible Polymers and Coated Fabrics
- E 77 Test Method for the Inspection and Verification of Thermometers
- E 220 Test Method for Calibration of Thermocouples by Comparison Techniques
- E 644 Test Methods for Testing Industrial Resistance Thermometers

¹ This test method is under the jurisdiction of ASTM Committee D20 on Plastics and is the direct responsibility of Subcommittee D20.30 on Thermal Properties (Section D20.30.07).

Current edition approved May 1, 2004. Published May 2004. Originally approved in 1943. Last previous edition approved in 1998 as D 746 - 98.

² For referenced ASTM standards, visit the ASTM website, www.astm.org, or contact ASTM Customer Service at service@astm.org. For *Annual Book of ASTM Standards* volume information, refer to the standard's Document Summary page on the ASTM website.

E 1137 Specification for Industrial Platinum Resistance Thermometers

2.2 ISO Standard:

ISO 974-1980 (E) Plastics—Determination of the Brittleness Temperature by Impact³

3. Terminology

3.1 *General*—The definitions of plastics used in this test method are in accordance with Test Method D 883 unless otherwise specified.

3.2 *brittleness temperature*—that temperature, estimated statistically, at which 50 % of the specimens would probably fail.

4. Summary of Test Method

4.1 To determine the brittleness temperature, specimens are secured to a specimen holder with a torque wrench. The specimen holder is immersed in a bath containing a heat-transfer medium that is cooled. The specimens are struck at a specified linear speed and then examined. The brittleness temperature is defined as the temperature at which 50 % of the specimens fail.

5. Significance and Use

5.1 This test method establishes the temperature at which 50 % of the specimens tested fail when subjected to the conditions specified herein. The test provides for the evaluation of long-time effects such as crystallization, or those effects that are introduced by low-temperature incompatibility of plasticizers in the material under test. Plastics and elastomers are used in many applications requiring low-temperature flexing with or without impact. Use data obtained by this method to predict the behavior of plastic and elastomeric materials at low temperatures only in applications in which the conditions of deformation are similar to those specified in this test method. This test method has been found useful for specification purposes, but does not necessarily measure the lowest temperature at which the material is suitable for use.

NOTE 3—Suitable apparatus is commercially available from several

³ *ISO Standards Handbook 21*, Vol 1. ISO Standards are available from American National Standards Institute (ANSI), 25 W. 43rd St., 4th Floor, New York, NY 10036.

*A Summary of Changes section appears at the end of this standard.

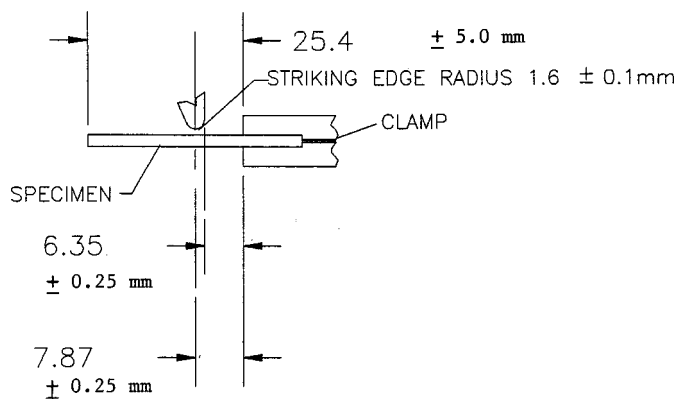

FIG. 1 Dimensional Requirements Between Specimen Clamp and Striking Edge (Type A)

suppliers. The striking member may be motor-driven, solenoid-operated, gravity-actuated, or spring-loaded. Equip the motor-driven tester with a safety interlock to prevent striker arm motion when the cover is open.

6. Apparatus

6.1 Type A:

6.1.1 *Specimen Clamp and Striking Member*—Design the specimen clamp to hold the specimen or specimens as a cantilever beam. Each individual specimen shall be firmly and securely held in a separate clamp. The striking edge shall move relative to the specimens at a linear speed of 2000 ± 200 mm/s at impact and during at least the following 6.4 mm of travel. In order to maintain this speed on some instruments, it is necessary to reduce the number of specimens tested at one time. The distance between the center line of the striking edge and the clamp shall be 7.87 ± 0.25 mm at impact. The striking edge shall have a radius of 1.6 ± 0.1 mm. The striking arm and specimen clamp shall have a clearance of 6.35 ± 0.25 mm at and immediately following impact. These dimensional requirements are illustrated in Fig. 1. Fig. 2 shows a typical clamp.⁴ Use free-fitting clamping screws, 10-32 National Fine Thread.

6.2 Type B:

6.2.1 *Specimen Clamp and Striking Member*—Design the specimen clamp to hold the specimen or specimens as a cantilever beam. Each individual specimen shall be firmly and securely held in a separate clamp. The striking edge shall move relative to the specimens at a linear speed of 2000 ± 200 mm/s at impact and during at least the following 5.0 mm of travel. In order to maintain this speed on some instruments, it is necessary to reduce the number of specimens tested at one time. The radius of the lower jaw of the clamp shall be 4.0 ± 0.1 mm. The striking edge shall have a radius of 1.6 ± 0.1 mm. The striking edge and specimen clamp shall have a clearance of 3.6 ± 0.1 mm at and immediately following impact. The clearance between the outside of the striking edge and the clamp shall be 2.0 ± 0.1 mm at impact. These dimensional requirements of the striking edge and clamping device are illustrated in Fig. 3. Fig. 4 shows a typical clamp. Details of the specimen clamp are given in Fig. 5.

⁴ A detailed drawing of a typical clamp may be obtained from ASTM Headquarters. Order Adjunct : ADJD0746.

6.3 Torque Wrench, 0 to 8.5 N · m.

NOTE 4—Because of the difference in geometry of the specimen clamps, test results obtained when using the Type A specimen clamp and striking member may not correlate with those results obtained when using the Type B apparatus.

6.4 *Temperature-Measurement System*—The temperature of the heat-transfer medium shall be determined with a thermocouple or resistance thermometer having a suitable range for the temperatures at which the determinations are to be made. The temperature-measuring device and the related readout equipment shall be accurate to at least $\pm 0.5^\circ\text{C}$. The temperature-measuring device shall be located as close to the specimens as possible. Thermocouples shall be calibrated in accordance with Test Method E 220. Resistance temperature devices shall comply with the requirements of Test Methods E 644 and Specification E 1137.

NOTE 5—A thermometer is permitted to be used if it is shown to agree with the specified temperature measuring system. Mercury-in-glass thermometers shall be calibrated for the depth of immersion in accordance with Test Method E 77.

6.5 *Heat-Transfer Medium*— Use any liquid heat transfer medium that remains fluid at the test temperature and does not appreciably affect the material being tested. Measurement of selected physical properties prior to and after 15-min exposure at the highest temperature used will provide an indication of the inertness of a plastic to the heat transfer medium.

6.5.1 Where a flammable or toxic solvent is used as the cooling medium, follow customary precautions when handling such materials. Methanol is the recommended heat transfer medium for rubber.

NOTE 6—The following materials have been found suitable for use at the indicated temperatures. When silicone oil is used, moisture from the air will condense on the surface of the oil, causing slush to form. If slush collects on the temperature-measuring device as ice, it will affect temperature measurement. When this occurs, remove the ice from the temperature-measuring device.

Material	Temperature, °C
5-mm ² /s viscosity silicone oil	-60
2-mm ² /s viscosity silicone oil	-76
Methyl alcohol	-90

6.6 *Temperature Control*—Suitable means (automatic or manual) shall be provided for controlling the temperature of the heat-transfer medium to within $\pm 0.5^\circ\text{C}$ of the desired value. Powdered solid carbon dioxide (dry ice) and liquid nitrogen are recommended for lowering the temperature, and an electric immersion heater for raising the temperature.

6.7 Tank, insulated.

6.8 *Stirrer*, to provide thorough circulation of the heat transfer medium.

7. Test Specimen

7.1 Type I (for Fixture Type A):

7.1.1 *Geometry*—This type of specimen shall be 6.35 ± 0.51 mm wide by 31.75 ± 6.35 mm long as illustrated in Fig. 6.

7.1.2 *Preparation*—Specimens shall be 1.91 ± 0.13 mm thick. Specimens shall be die-punched, cut by hand using a

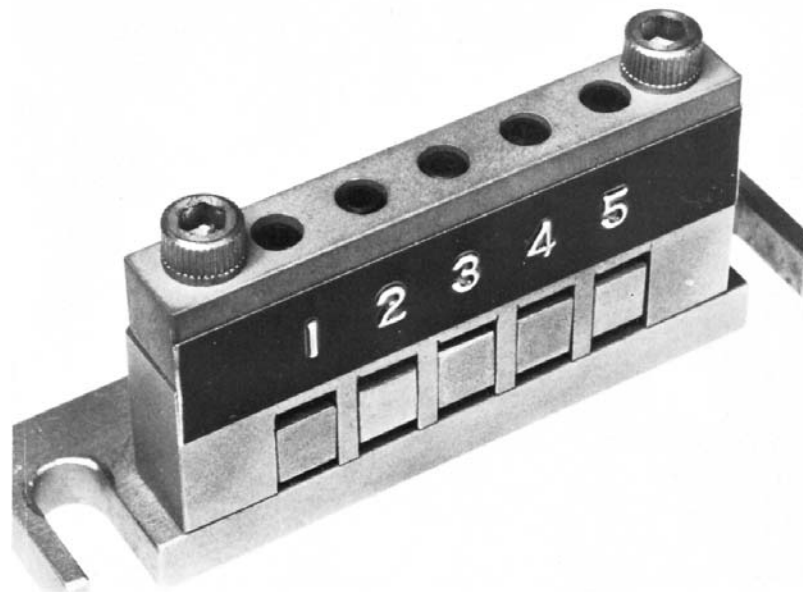
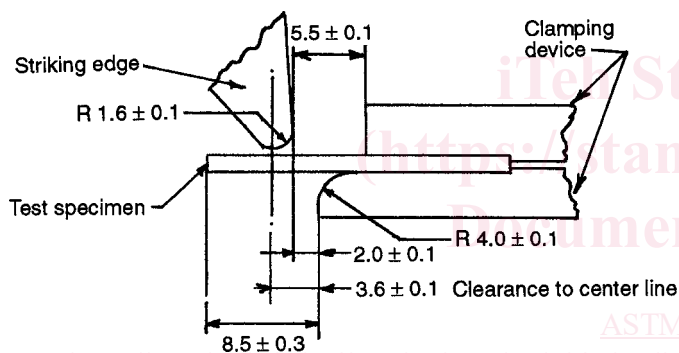

FIG. 2 Typical Clamp (Type A)



NOTE—Dimensions are in millimetres.

FIG. 3 Dimensional Details of Striking Edge and Clamping Device, Type B (Positioning of Unnotched Test Specimen)

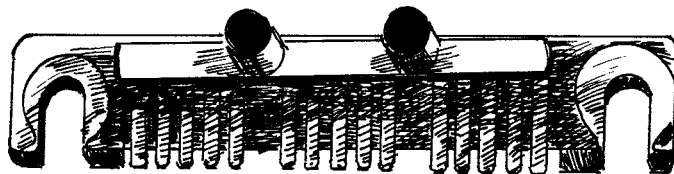

FIG. 4 Assembled Clamp with Test Specimens, Type B

razor blade or other sharp tool, or cut by an automatic machine from flat sheet, or prepared by injection molding.

7.2 Type II (for Fixture Type A):

7.2.1 *Geometry (Modified T-50 Specimen)*—This type of specimen shall be T-shaped, as illustrated in Fig. 6. When using this type of specimen, clamp it so that the entire tab is inside the jaws for a minimum distance of 3.18 mm.

7.2.2 *Preparation*—Specimens shall be 1.91 ± 0.13 mm thick. Specimens shall be die-punched, cut by hand using a razor blade or other sharp tool, or cut by an automatic machine from flat sheet, or prepared by injection molding.

7.3 Type III (for Fixture Type B):

7.3.1 *Geometry*—This type of specimen shall be 20.0 ± 0.25 mm long by 2.5 ± 0.05 mm wide and 1.6 ± 0.1 mm thick as illustrated in Fig. 6.

7.3.2 *Preparation*—Specimens shall be die-punched, cut by hand using a razor blade or other sharp tool, or cut by an automatic machine from flat sheet, or prepared by injection molding.

7.4 Test results will vary according to molding conditions and methods of specimen preparation. It is essential that preparation methods produce uniform specimens. The preferred method of preparation is to use an automatic cutting machine, however specimens that are punched using an arbor press or hydraulically operated press are also acceptable. No matter which preparation method is employed, the specimen edges shall be free of all flash. Specimens that are damaged in any way shall be discarded. If specimens are to be die punched, sharp dies must be used in the preparation of specimens for this test if reliable results are to be achieved. Careful maintenance of die cutting edges is of extreme importance and is obtained by daily lightly honing and touching up the cutting edges with jewelers' hard Arkansas honing stones. The condition of the die is judged by investigating the rupture point on any series of broken specimens. When broken specimens are removed from the clamps of the testing machine it is advantageous to pile these specimens and note if there is any tendency to break at or near the same portion of each specimen. Rupture points consistently at the same place are the indication that the die is dull, nicked, or bent at that particular position, or that some other defect is present.

8. Conditioning

8.1 *Conditioning*—Condition the test specimens at $23 \pm 2^\circ\text{C}$ and $50 \pm 5\%$ relative humidity for not less than 40 h prior to the test in accordance with Procedure A of Practice

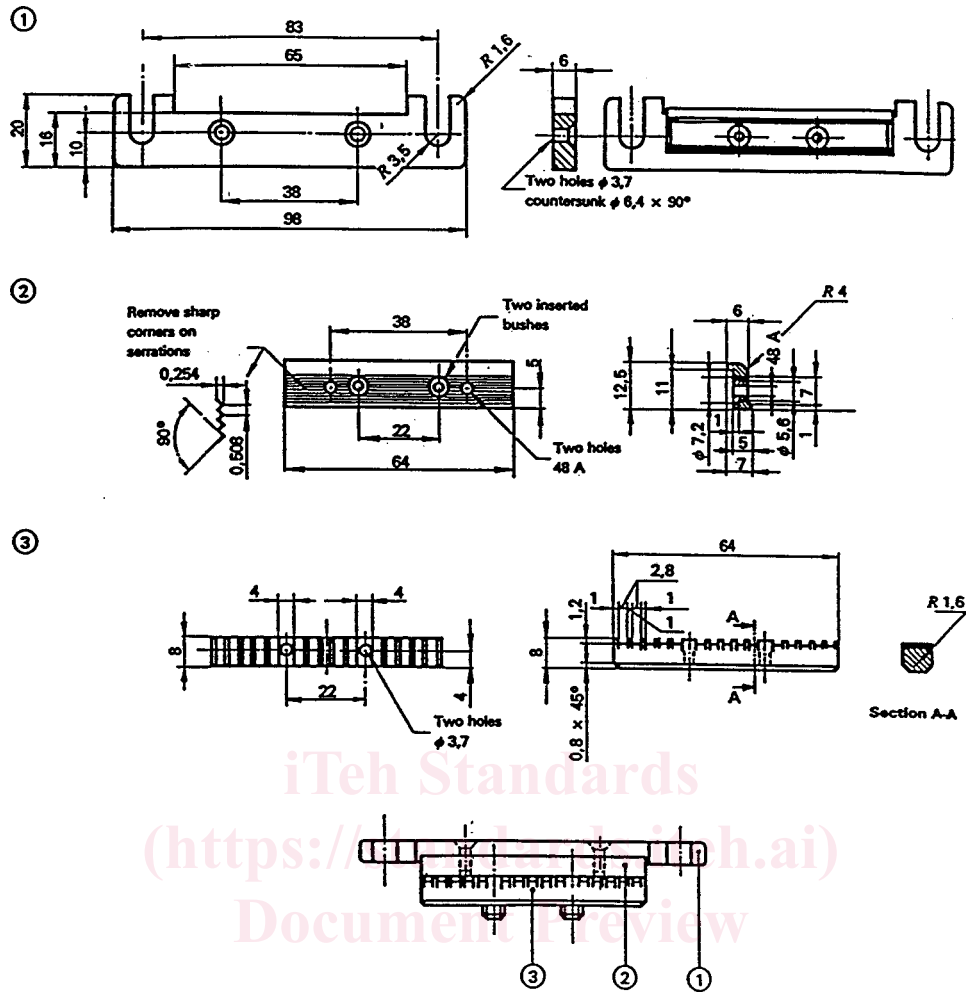

NOTE—Dimensions are in millimetres.

FIG. 5 Details of One Form of Clamp Meeting the Requirements of 6.2

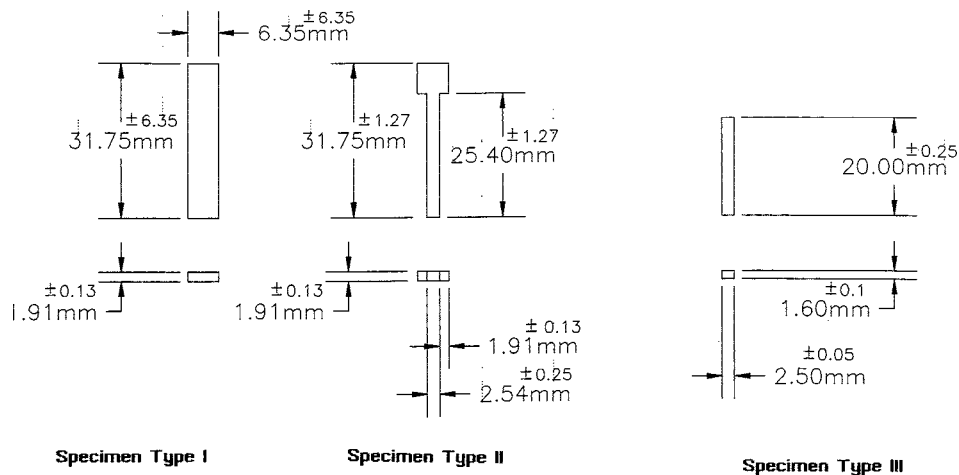

FIG. 6 Specimen Geometry

D 618 for those tests where conditioning is required. In cases of disagreement, the tolerances shall be $\pm 1^\circ\text{C}$ and $\pm 2\%$ relative humidity.

8.2 Where long-time effects such as crystallization, incompatibility, and so forth, of materials are to be studied, condition the test specimens in accordance with Practice D 832.