

First edition
2007-02-01

Corrected version
2007-04-01

**Liquid pumps and pump units — Noise
test code — Grades 2 and 3 of accuracy**

*Pompes et groupes motopompes pour liquides — Code d'essai
acoustique — Classes de précision 2 et 3*

iTeh STANDARD PREVIEW
(standards.iteh.ai)

[ISO 20361:2007](https://standards.iteh.ai/catalog/standards/sist/a6e2dd0a-cd55-4083-a5b2-c464792d05ea/iso-20361-2007)

[https://standards.iteh.ai/catalog/standards/sist/a6e2dd0a-cd55-4083-a5b2-
c464792d05ea/iso-20361-2007](https://standards.iteh.ai/catalog/standards/sist/a6e2dd0a-cd55-4083-a5b2-c464792d05ea/iso-20361-2007)



Reference number
ISO 20361:2007(E)

© ISO 2007

PDF disclaimer

This PDF file may contain embedded typefaces. In accordance with Adobe's licensing policy, this file may be printed or viewed but shall not be edited unless the typefaces which are embedded are licensed to and installed on the computer performing the editing. In downloading this file, parties accept therein the responsibility of not infringing Adobe's licensing policy. The ISO Central Secretariat accepts no liability in this area.

Adobe is a trademark of Adobe Systems Incorporated.

Details of the software products used to create this PDF file can be found in the General Info relative to the file; the PDF-creation parameters were optimized for printing. Every care has been taken to ensure that the file is suitable for use by ISO member bodies. In the unlikely event that a problem relating to it is found, please inform the Central Secretariat at the address given below.

iTeh STANDARD PREVIEW
(standards.iteh.ai)

[ISO 20361:2007](https://standards.iteh.ai/catalog/standards/sist/a6e2dd0a-cd55-4083-a5b2-c464792d05ea/iso-20361-2007)

<https://standards.iteh.ai/catalog/standards/sist/a6e2dd0a-cd55-4083-a5b2-c464792d05ea/iso-20361-2007>

© ISO 2007

All rights reserved. Unless otherwise specified, no part of this publication may be reproduced or utilized in any form or by any means, electronic or mechanical, including photocopying and microfilm, without permission in writing from either ISO at the address below or ISO's member body in the country of the requester.

ISO copyright office
Case postale 56 • CH-1211 Geneva 20
Tel. + 41 22 749 01 11
Fax + 41 22 749 09 47
E-mail copyright@iso.org
Web www.iso.org

Published in Switzerland

Contents

Page

| | |
|--|-----------|
| Foreword..... | iv |
| Introduction | v |
| 1 Scope | 1 |
| 2 Normative references | 1 |
| 3 Terms and definitions..... | 2 |
| 4 Pump family and pump configuration | 2 |
| 5 Sound power level determination | 3 |
| 6 Emission sound pressure level determination | 10 |
| 7 Installation and mounting conditions..... | 11 |
| 8 Operating conditions during noise measurement | 12 |
| 9 Information to be recorded | 12 |
| 10 Declaration and verification of noise emission values..... | 13 |
| Annex A (normative) Pump alone — Measurement surface..... | 14 |
| Annex B (normative) Pump units — Microphone positions for sound pressure level measurement on the measurement surface for different pump types and sizes..... | 15 |

[ISO 20361:2007](https://standards.iteh.ai/catalog/standards/sist/a6e2dd0a-cd55-4083-a5b2-c464792d05ea/iso-20361-2007)

<https://standards.iteh.ai/catalog/standards/sist/a6e2dd0a-cd55-4083-a5b2-c464792d05ea/iso-20361-2007>

Foreword

ISO (the International Organization for Standardization) is a worldwide federation of national standards bodies (ISO member bodies). The work of preparing International Standards is normally carried out through ISO technical committees. Each member body interested in a subject for which a technical committee has been established has the right to be represented on that committee. International organizations, governmental and non-governmental, in liaison with ISO, also take part in the work. ISO collaborates closely with the International Electrotechnical Commission (IEC) on all matters of electrotechnical standardization.

International Standards are drafted in accordance with the rules given in the ISO/IEC Directives, Part 2.

The main task of technical committees is to prepare International Standards. Draft International Standards adopted by the technical committees are circulated to the member bodies for voting. Publication as an International Standard requires approval by at least 75 % of the member bodies casting a vote.

Attention is drawn to the possibility that some of the elements of this document may be the subject of patent rights. ISO shall not be held responsible for identifying any or all such patent rights.

ISO 20361 was prepared by Technical Committee ISO/TC 115, *Pumps*.

This corrected version of ISO 20361:2007 incorporates the removal of "FDIS" from the footer on the cover page and from the header on succeeding pages.

ISO 20361:2007
<https://standards.iteh.ai/catalog/standards/sist/a6e2dd0a-cd55-4083-a5b2-c464792d05ea/iso-20361-2007>

Introduction

The noise emitted by a pump unit can be radiated by the casing of the pump, the driving system (e.g. motor, gear box, coupling), the piping system and all the connected structures.

On site, the perceived noise can be significantly increased by reverberation effects or by the radiation of extraneous sources.

Depending on the type of pump it may be useful to know

- a) the noise of the pumping system (including piping);
- b) the noise of the pump unit, including the driver and the transmission elements but excluding the noise of the piping system;
- c) the noise emitted by the pump alone, excluding the noise from the driver, transmission elements and the pipings;
- d) the noise emitted by each of those elements in respect to a given requirement or in view of an efficient sound proofing of the installation.

This International Standard describes methods for the determination of the noise emitted by a pump unit [case b)] or a pump alone [case c)]. Noise emission is expressed in terms of the sound power level of the machine and the emission sound pressure level at the relevant work station (see 6.2).

This International Standard is intended to enable the manufacturer to

- show the effectiveness of noise reduction,
- declare the noise emission levels.

This International Standard is a type C standard as stated in ISO 12100-1 and ISO 12100-2.

When provisions of this type C standard are different from those which are stated in A or B standards, the provisions of this type C standard take precedence.

The machinery concerned and the extent to which noise is covered are indicated in the scope of this International Standard.

iTeh STANDARD PREVIEW
(standards.iteh.ai)

ISO 20361:2007

<https://standards.iteh.ai/catalog/standards/sist/a6e2dd0a-cd55-4083-a5b2-c464792d05ea/iso-20361-2007>

Liquid pumps and pump units — Noise test code — Grades 2 and 3 of accuracy

1 Scope

This International Standard specifies all the information necessary to carry out efficiently and under standardized conditions the determination, declaration and verification of the airborne noise emission of liquid pumps or pump units (see 4.1). It specifies the noise measurement methods and the operating and mounting conditions that shall be used for the test.

Noise emission characteristics include emission sound pressure levels at specified positions and the sound power level. The determination of these quantities is necessary for

- declaring the noise emission values,
- purpose of noise control at source at the design stage.

NOTE 1 The determination of these quantities is also necessary for comparing the noise emitted by liquid pumps on the market.

The use of this International Standard ensures the reproducibility of the determination of the airborne noise-emission characteristics within specified limits determined by the grade of accuracy of the basic airborne noise measurement method used. Noise measurement methods according to this International Standard are engineering methods (grade 2) and survey methods (grade 3).

This International Standard does not deal with the characterization of the structure-borne sound and liquid-borne noise generated by liquid pumps.

NOTE 2 This International Standard is intended to complement EN 809, *Pumps and pump units for liquids — Common safety requirements*.

2 Normative references

The following referenced documents are indispensable for the application of this document. For dated references, only the edition cited applies. For undated references, the latest edition of the referenced document (including any amendments) applies.

ISO 3743-1¹⁾, *Acoustics — Determination of sound power levels and sound energy levels of noise sources using sound pressure — Engineering method for small, movable sources in reverberant fields — Part 1: Comparison method for a hard-walled test room*

ISO 3743-2, *Acoustics — Determination of sound power levels of noise sources using sound pressure — Engineering methods for small, movable sources in reverberant fields — Part 2: Methods for special reverberation test rooms*

ISO 3744²⁾, *Acoustics — Determination of sound power levels of noise sources using sound pressure — Engineering method in an essentially free field over a reflecting plane*

1) To be published. (Revision of ISO 3743-1:1994)

2) To be published. (Revision of ISO 3744:1994)

ISO 3746³⁾, *Acoustics — Determination of sound power levels of noise sources using sound pressure — Survey method using an enveloping measurement surface over a reflecting plane*

ISO 4871:1996, *Acoustics — Declaration and verification of noise emission values of machinery and equipment*

ISO/TR 7849, *Acoustics — Estimation of airborne noise emitted by machinery using vibration measurement*

ISO 9614-1, *Acoustics — Determination of sound power levels of noise sources using sound intensity — Part 1: Measurement at discrete points*

ISO 9614-2:1996, *Acoustics — Determination of sound power levels of noise sources using sound intensity — Part 2: Measurement by scanning*

ISO 11203:1995, *Acoustics — Noise emitted by machinery and equipment — Determination of emission sound pressure levels at the work station and at other specified positions from the sound power level*

ISO 12100-1, *Safety of machinery — Basic concepts, general principles for design — Part 1: Basic terminology, methodology*

ISO 12100-2, *Safety of machinery — Basic concepts, general principles for design — Part 2: Technical principles*

ISO 17769, *Liquid pumps — General terms and installation — Definitions, quantities, letter symbols and units*

iTeh STANDARD PREVIEW

3 Terms and definitions standards.iteh.ai

For the purposes of this document, the definitions given in ISO 17769 and the following apply.

[ISO 20361:2007](https://standards.iteh.ai/catalog/standards/sist/a6e2dd0a-cd55-4083-a5b2-c464792d05ea/iso-20361-2007)

3.1 pump <https://standards.iteh.ai/catalog/standards/sist/a6e2dd0a-cd55-4083-a5b2-c464792d05ea/iso-20361-2007>

equipment that is defined as being terminated by its inlet and outlet branches as well as in general its shaft ends

3.2 pump unit

equipment that is comprised of the pump as described in 3.1 and its driver (e.g. electric motor, steam turbine) including transmission elements (e.g. coupling, gear), baseplates and any auxiliary equipment supplied with the pump

4 Pump family and pump configuration

4.1 Pumps covered by this International Standard comprise liquid pumps of the rotodynamic and positive displacement, rotary and reciprocating types.

4.2 This International Standard provides two possibilities of measurement, either pump alone (see Table 1), or pump units (see Table 2). In these two cases, the pumps shall be installed

- on site (see 7.2.2), or
- on shop test stand (see 7.2.3), or
- in a specific facility intended for acoustic measurement (see 7.2.4).

3) To be published. (Revision of ISO 3746:1995)

4.3 Safety guards, e.g. coupling guards, insulation hoods etc., if any, shall be installed during noise-emission determination.

5 Sound power level determination

5.1 General

One of the following grade 2 of accuracy methods for determining the sound power level shall be used:

- ISO 3743-1 or ISO 3743-2;

NOTE 1 ISO 3743-1 is based upon a hard-walled room and low background noise. This International Standard gives specifications to sound pressure level measurement in octave bands, in order to calculate the sound power level.

NOTE 2 ISO 3743-2 is based upon special reverberation test room. This International Standard gives specifications to A-weighted sound pressure level measurement in order to calculate the sound power level.

- ISO 3744;

NOTE 3 ISO 3744 is based upon a non reverberant environment and low background noise. This International Standard specifies a method to calculate the sound power level from the measured A-weighted sound pressure levels or sound pressure levels in octave or third octave bands.

- ISO 9614-1 or ISO 9614-2;

If it has been shown that the applicability requirements of these grade 2 standards cannot be attained, e.g. too much background noise, then one of the following grade 3 methods shall be used:

- ISO 3746; <https://standards.iteh.ai/catalog/standards/sist/a6e2dd0a-cd55-4083-a5b2-c464792d05ea/iso-20361-2007>

NOTE 4 ISO 3746 is less demanding, it only gives specifications to the measurement of A-weighted sound pressure levels and provides A-weighted sound power levels with grade 3 of accuracy.

- ISO 9614-1 or ISO 9614-2;

NOTE 5 ISO 9614 (all parts) can be used in all environments, including reverberation and extraneous noise sources to a large extent. This International Standard gives specifications to sound intensity and sound pressure measurement. Depending on the level of the reverberation and extraneous noise, it provides the sound power level either as A-weighted overall level or in octave or third-octave band. For grade 3 measurements, only the overall A-weighted sound power level is available.

NOTE 6 ISO 9614-1 requires measurements of sound intensity and simultaneously sound pressure level (at discrete points). In this case, the number of points is generally higher than the number of points used for the standards based on sound pressure measurements.

NOTE 7 ISO 9614-2 requires measurement of sound intensity and simultaneously sound pressure level by scanning. This can be made on partial or global surface depending on the configuration of the machine. The method generally reduces the measurement time.

- ISO/TR7849.

NOTE 8 ISO/TR 7849 is a technical report that can be used only when the prescriptions of the other methods are not fulfilled. This method is based upon measurement of vibration velocity of the relevant parts of the pump or pump unit. It provides an estimation of the A-weighted sound power level or sound power level in octave or third octave bands.

For selection of the basic International Standard for determination of the sound power level of a pump, Table 1 for pumps (pump alone) and Table 2 for pump units shall be used.

The reflecting plane shall be either a hard plane or a surface of water.

The International Standard, indicated in bold letters in Tables 1 and 2, describes the preferred method and shall be used where practical. If it is not practical, one of the other noted basic International Standards shall be used.

Table 1 — Pump (pump alone) — Selection of International Standards for determination of sound power level

| Test arrangement | Grade | Pump power input <i>P</i> kW | | | |
|--------------------------------|-------|--|---|--|---|
| | | $0,5 < P \leq 15$ | $15 < P \leq 75$ | $75 < P \leq 300$ | $P > 300$ |
| Specific facility ^a | 2 | ISO 3744 ISO 3743-2 ISO 9614 ^b | ISO 9614^b ISO 3744 ISO 3743-2 | ISO 9614^b ISO 3744 | ISO 9614^b ISO 3744 |
| Shop test stand | 2 | ISO 9614^b | | | impractical |
| | 3 | ISO 9614^b ISO 3746 | | ISO 9614^b | |
| On site | 2 | ISO 9614^b | | | impractical |
| | 3 | ISO 9614^b ISO 3746 | | ISO 9614^b ISO TR 7849 | |

^a A facility can be qualified as specifically designed for noise measurements if it yields grade 2 measurements.

^b ISO 9614 means ISO 9614-1 or ISO 9614-2.

ISO 20361:2007
<https://standards.iteh.ai/catalog/standards/sist/a6e2dd0a-cd55-4083-a5b2-c90772d05ca/iso-20361-2007>
Table 2 — Pump unit — Selection of standards for determination of sound power level

| Test arrangement | Grade | Pump power input <i>P</i> kW | | | |
|--------------------------------|-------|---|--|--|---|
| | | $0,5 < P \leq 15$ | $15 < P \leq 75$ | $75 < P \leq 300$ | $0,5 < P \leq 15$ |
| Specific facility ^a | 2 | ISO 3744 ISO 3743-2 ISO 9614 ^b | | ISO 3744 ISO 9614 ^b | ISO 9614^b ISO 3744 |
| Shop test stand | 2 | ISO 3744 ISO 3743-1 ^c ISO 9614 ^b | ISO 3744 ISO 9614 ^b | ISO 9614^b ISO 3744 | ISO 9614^b |
| | 3 | ISO 3746 ISO 9614 ^b | | ISO 9614^b ISO 3746 | ISO 9614^b ISO 3746 |
| On site | 2 | ISO 9614^b ISO 3744 | | | ISO 9614^b |
| | 3 | ISO 3746 ISO 9614 ^b | | ISO 9614^b ISO 3746 | |

^a A facility can be qualified as specifically designed for noise measurements if it yields grade 2 measurements.

^b ISO 9614 means ISO 9614-1 or ISO 9614-2.

^c ISO 3743-1 may be used for pump units in a shop test stand at the condition that pipings are properly lagged.

5.2 Specific considerations for reference box, measurement surface, position of microphones and intensity probe

5.2.1 General

When ISO 3744, ISO 3746 or ISO 9614 is used, 5.2.2 to 5.2.4 apply.

5.2.2 Reference box

The reference box is an hypothetical surface, the smallest simple volume (parallelepiped, box, cylinder, etc.) containing the pump unit or pump and the flanges of the machine but excluding the pipings for the pump unit and pipings, transmission elements and driver for pumps (pump alone) and small individual components of the source that do not contribute to the sound radiation. For ISO 3744 and ISO 3746, the reference box is a parallelepiped. The box encloses the source and terminates on the reflecting plane (hard ground or water). For examples of reference boxes see Figures 1 and 2.

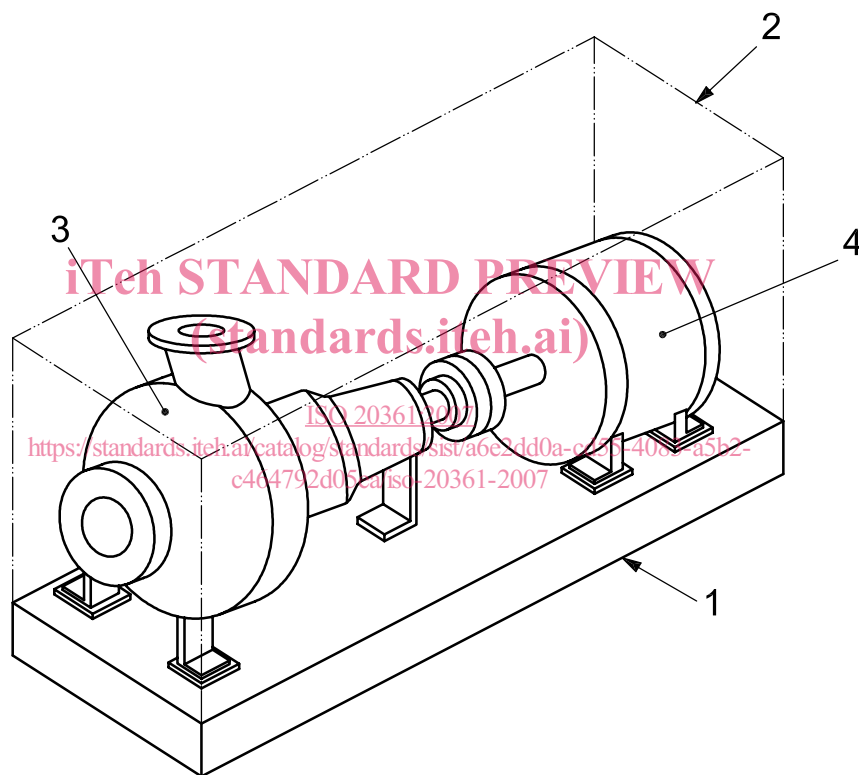

Key

- 1 reflecting plane
- 2 reference box
- 3 pump
- 4 driver

Figure 1 — Reference box for pump unit (example)