

**SLOVENSKI STANDARD**  
**SIST-TP CEN ISO/TR 17641-3:2005**  
**01-maj-2005**

Dcfi ý]hj Yb]dfYg\_i g]nj Ufcj `bU\_cj ]bg\_]\ `a UHf]U]\ `ÈDfYg\_i g]`bUdc\_Ub^Yj  
j fc Ya `nUnj UfbYgdc^ÈCVc b]`bU ]b]j Uf^b^UÈ' "XY.`DfYg\_i g`bU  
cVfYa Yb^bYa `dfYg\_i ýUbW `fIGC#HF`%\*(%' .&\$)Ł

Destructive tests on welds in metallic materials - Hot cracking tests for weldments - Arc welding processes - Part 3: Externally loaded tests (ISO/TR 17641-3:2005)

Zerstörende Prüfung von Schweißverbindungen an metallischen Werkstoffen - Heißrissprüfungen für Schweißungen - Lichtbogenschweißprozesse - Teil 3: Fremdbeanspruchte Prüfungen (ISO/TR 17641-3:2005)

Essais destructifs des soudures sur matériaux métalliques - Essais de fissuration a chaud des assemblages soudés - Procédés de soudage a l'arc - Partie 3 : Essais sur éprouvette soumise a une charge extérieure (ISO/TR 17641-3:2005)

**Ta slovenski standard je istoveten z: CEN ISO/TR 17641-3:2005**

**ICS:**

25.160.40 Varjeni spoji in vari Welded joints

**SIST-TP CEN ISO/TR 17641-3:2005 en**

**iTeh STANDARD PREVIEW**  
**(standards.iteh.ai)**

SIST-TP CEN ISO/TR 17641-3:2005

<https://standards.iteh.ai/catalog/standards/sist/2cc94db3-a1b9-4ad0-8187-6178324c19d5/sist-tp-cen-iso-tr-17641-3-2005>

TECHNICAL REPORT  
RAPPORT TECHNIQUE  
TECHNISCHER BERICHT

**CEN ISO/TR 17641-3**

March 2005

ICS 25.160.40

English version

**Destructive tests on welds in metallic materials - Hot cracking tests for weldments - Arc welding processes - Part 3: Externally loaded tests (ISO/TR 17641-3:2005)**

Essais destructifs des soudures sur matériaux métalliques -  
Essais de fissuration à chaud des assemblages soudés -  
Procédés de soudage à l'arc - Partie 3 : Essais sur  
éprouvette soumise à une charge extérieure (ISO/TR  
17641-3:2005)

Zerstörende Prüfung von Schweißverbindungen an  
metallischen Werkstoffen - Heißrissprüfungen für  
Schweißungen - Lichtbogenschweißprozesse - Teil 3:  
Frembeanspruchte Prüfungen (ISO/TR 17641-3:2005)

This Technical Report was approved by CEN on 20 March 2004. It has been drawn up by the Technical Committee CEN/TC 121.

CEN members are the national standards bodies of Austria, Belgium, Cyprus, Czech Republic, Denmark, Estonia, Finland, France, Germany, Greece, Hungary, Iceland, Ireland, Italy, Latvia, Lithuania, Luxembourg, Malta, Netherlands, Norway, Poland, Portugal, Slovakia, Slovenia, Spain, Sweden, Switzerland and United Kingdom.

**HIGH STANDARD PREVIEW**  
**(standards.iteh.ai)**

[SIST-TP CEN ISO/TR 17641-3:2005](https://standards.iteh.ai/catalog/standards/sist/2cc94db3-a1b9-4ad0-8187-6178324c19d5/sist-tp-cen-iso-tr-17641-3-2005)

<https://standards.iteh.ai/catalog/standards/sist/2cc94db3-a1b9-4ad0-8187-6178324c19d5/sist-tp-cen-iso-tr-17641-3-2005>



EUROPEAN COMMITTEE FOR STANDARDIZATION  
COMITÉ EUROPÉEN DE NORMALISATION  
EUROPÄISCHES KOMITEE FÜR NORMUNG

**Management Centre: rue de Stassart, 36 B-1050 Brussels**

## CEN ISO/TR 17641-3:2005 (E)

## Contents

page

Foreword.....	3
1 Scope .....	4
2 Normative references .....	4
3 Terms and definitions .....	4
4 Symbols, designations and units.....	4
5 Principle.....	5
6 Description of the tests.....	7
6.1 Hot tensile test .....	7
6.1.1 General.....	7
6.1.2 Specimen size .....	7
6.1.3 Protective atmosphere .....	8
6.1.4 Test procedure .....	8
6.1.5 Test results .....	8
6.2 Principles of the Vareststraint and Transvareststraint tests.....	9
6.2.1 General principles.....	9
6.2.2 Specimen size .....	12
6.2.3 Test procedure .....	12
6.2.4 Test results .....	12
6.3 Flat tensile test.....	14
6.3.1 General.....	14
6.3.2 Specimen size .....	14
6.3.3 Test procedure .....	15
6.3.4 Test results .....	16
7 Test reports .....	17

## Figures

Figure 1 — Specimen dimensions for the hot tensile test .....	7
Figure 2 — Results presentation .....	9
Figure 3 — Principle of Vareststraint (up) /Transvareststraint tests (down) .....	11
Figure 4 — Typical presentation of results for The Vareststraint and Transvareststraint tests .....	13
Figure 5 — Programmable Deformation Cracking Test (PVR-Test) — Test piece dimension .....	15
Figure 6 — Test procedure of Programmable Deformation Cracking Test (PVR-Test).....	16

## Tables

Table 1 — Designation and symbols .....	5
Table 2 — Hot cracking tests, types of cracking and applications .....	6

## Foreword

This document (CEN ISO/TR 17641-3:2005) has been prepared by Technical Committee CEN/TC 121 "Welding", the secretariat of which is held by DIN, in collaboration with Technical Committee ISO/TC 44 "Welding and allied processes".

## iTeh STANDARD PREVIEW (standards.iteh.ai)

[SIST-TP CEN ISO/TR 17641-3:2005](https://standards.iteh.ai/catalog/standards/sist/2cc94db3-a1b9-4ad0-8187-6178324c19d5/sist-tp-cen-iso-tr-17641-3-2005)

<https://standards.iteh.ai/catalog/standards/sist/2cc94db3-a1b9-4ad0-8187-6178324c19d5/sist-tp-cen-iso-tr-17641-3-2005>

**CEN ISO/TR 17641-3:2005 (E)****1 Scope**

This document outlines the test methods and procedures for carrying out externally loaded tests to assess susceptibility to hot cracking.

The following tests are described:

- Hot tensile tests
- Varestreint and Transvarestreint test
- Flat tensile test.

The above tests can provide information about the hot cracking sensitivity of parent materials, weld metals and weldments. Assessment is based upon the measurement of the "brittle temperature range" (BTR) where hot cracks occur.

This document applies primarily to austenitic stainless steels, nickel, nickel base and nickel copper alloys, weldments and welding consumables. However, the principles can be extended to other materials such as aluminium alloys and high strength steels by agreement between contracting parties.

**2 Normative references**

**iTeh STANDARD PREVIEW**  
(standards.iteh.ai)

The following referenced document is indispensable for the application of this document. For dated references, only the edition cited applies. For undated references, the latest edition of the referenced document (including any amendments) applies.

EN ISO 17641-1:2004, *Destructive tests on welds in metallic materials — Hot cracking tests for weldments — Arc welding processes — Part 1: General (ISO 17641-1:2004)*

**3 Terms and definitions**

For the purposes of this document, the terms and definitions given in EN ISO 17641-1:2004 apply.

**4 Symbols, designations and units**

For the purposes of this document, the symbols and units given in Table 1 apply.

Table 1 — Designation and symbols

Symbol	Designation	Unit
<b>Hot tensile test</b>		
BTR	Brittle temperature range, i.e. difference between NST and DTR (see Figure 2)	°C
DRR	Ductility recovery rate, difference (2—3)/(1—3) × 100 (see Figure 2)	%
DRT	Ductility recovery temperature, i.e. temperature at 5% reduction in area measured during "on cooling" tensile test	°C
NDR	Nil ductility temperature range, distance (4—6 see Figure 2)	°C
NST	Nil strength temperature, i.e. peak temperature of the test (See Figure 2, Point 6)	°C
RDR	Ratio of ductility recovery, area (2—3—4)/area (1—3—5) × 100 (See Figure 2)	-
$R_m$	Ultimate tensile strength	MPa
Z	Reduction in area	%
$T_s$	Solidus temperature (See Figure 2, Point 7)	°C
<b>Varestraint- and Transvarestraint test</b>		
$L_{tot}$	Total length of all detected hot cracks	mm
$l$	Specimen length	mm
$R$	Radius of the former	mm
$t$	Specimen thickness	mm
$w$	Specimen width	mm
<b>Flat tensile test</b>		
$S_s$	Specimen strain	%
$S_v$	Strain rate	mm/s
$V_{crit}$	Critical strain to form the first hot crack	mm/s
$W_s$	Welding speed	cm/min

## 5 Principle

Externally loaded hot cracking tests may be used to provide quantitative information on solidification, liquation and ductility dip cracking in accordance with Table 2. They are suitable for assessing the susceptibility to hot cracking of parent materials, weldments and weld metals. However it should be recognised that the exact mechanisms of the various forms of hot cracking are not fully understood. The different externally loaded tests described in this document use different criteria for the assessment of susceptibility to hot cracking. None of the tests reproduce exactly the conditions of temperature, cooling rate, restraint and externally applied strains, which occur in a wide range of fabrications where hot cracking may be considered to be a potential problem. Although work continues to address these issues, the tests in their presently developed form can only be used to rank materials, welding consumables and welding conditions. The results can then be compared with databases of relevant experience to make judgements as to potential suitability. For this reason it is not possible to state that any particular test is the most appropriate for any specific requirement. The user of the test shall decide on the basis of past experience, or on preliminary experiments, which is the most appropriate test for the required application.

Four types of hot cracking test are described and their relevance to the various forms of hot cracking, and their possible range of application, are summarised in Table 2.

All the hot cracking tests described depend on the imposition of an external load on the specimen using suitable test equipment.

## CEN ISO/TR 17641-3:2005 (E)

This external loading can produce a measurable strain and strain rate on the specimen during the brittle temperature range (BTR) and can therefore reproduce certain aspects of the welding process. The results produced from this test are quantitative and are generally reproducible for the same test using a defined testing procedure and similar equipment.

Unfortunately, equipment and testing procedures are not standardised between different laboratories, and absolute reproducibility between laboratories is limited. Repeatability of results within a single laboratory using consistent procedures and the same equipment is generally good.

When parent materials are to be tested, the test specimen is heated either with a TIG melt run in the case of the Vareststraint and flat tensile test or by resistance heating in the hot tensile test. In both cases a HAZ is formed which is subjected to straining and hence assessment of susceptibility to cracking.

When weld metal is to be tested, a weld deposit is made by the appropriate arc welding process and in the cases of the Vareststraint and flat tensile test, is subjected to straining as the weld solidifies. Any cracking, which occurs, forms the basis of the assessment. For the hot tensile test the specimen is extracted from a multipass welded joint and assessment is based on measured mechanical properties using the appropriate procedure, see 6.1.1

Multipass welds can also be assessed using the Vareststraint and flat tensile test, but for these tests, samples with multipass deposits have to be prepared and the weld metal is then reheated using a similar TIG melt run to that utilised in parent material tests.

**Table 2 — Hot cracking tests, types of cracking and applications**

Type of test	Type of cracking	Results	Applications
Vareststraint	Solidification	$L_{tot}$ , BTR	Parent material, selection and approval.
	Liquation	$L_{tot}$	Weld metal, selection and approval.
	Ductility Dip	$L_{tot}$	Welding procedures
Transvareststraint	Solidification	$L_{tot}$	Weld metal selection Welding procedures
Flat tensile type (PVR test)	Solidification	$V_{crit}$	Material selection,
	Liquation	$V_{crit}$	Multipass weldments
	Ductility Dip	$V_{crit}$	Welding procedures Material combinations
Hot tensile test (Gleeble™)	Solidification	BTR	Material selection and approval
	Liquation	BTR	

Although it is possible for more than one form of hot cracking to be present in a given test piece it should be noted that the formation of one type of cracking e.g. solidification, may relieve the test strain on the specimen to such an extent that other forms of cracking do not occur. Therefore the lack of a particular form of cracking in the testpiece, does not mean that there is no risk of that type of cracking occurring in practice.

The Transvareststraint test was primarily designed to assess weld metal solidification cracking by applying strains transverse to the length of the weld. It is possible that other types of hot cracking form and if these do occur, they should be noted on the test report.



## 6 Description of the tests

### 6.1 Hot tensile test

#### 6.1.1 General

The hot tensile test determines the hot cracking susceptibility of a material in a simulated welding thermal cycle using a cylindrical shaped tensile specimen. The specimen can be abruptly broken at any convenient moment in the welding thermal cycle. For the study of hot cracking where it is necessary to simulate fusion welding thermal heating, a specimen shall be heated to its melting temperature. A number of cylindrical tensile test specimens are used, which can be loaded to failure at a predefined point (Procedure A).

To simulate the HAZ thermal history and liquation cracking, the specimen is heated only as far as the nil strength temperature (NST) rather than the melting point. This procedure is the same for both liquation cracking in the HAZ of parent materials and the interrun HAZ's of multipass welds (Procedure B). The test procedures are primarily used in weld metal hot cracking studies. The tests are characterised by good reproducibility.

#### 6.1.2 Specimen size

Procedure A — to simulate solidification cracking and heating to the melting point, a specimen of length 130 mm and diameter 10 mm should be used.

Procedure B — to simulate HAZ liquation cracking and to determine the NST, a specimen of length 110 mm and diameter 6 mm should be used.

The specimen dimension together with the location of the weld joint are shown in Figure 1.

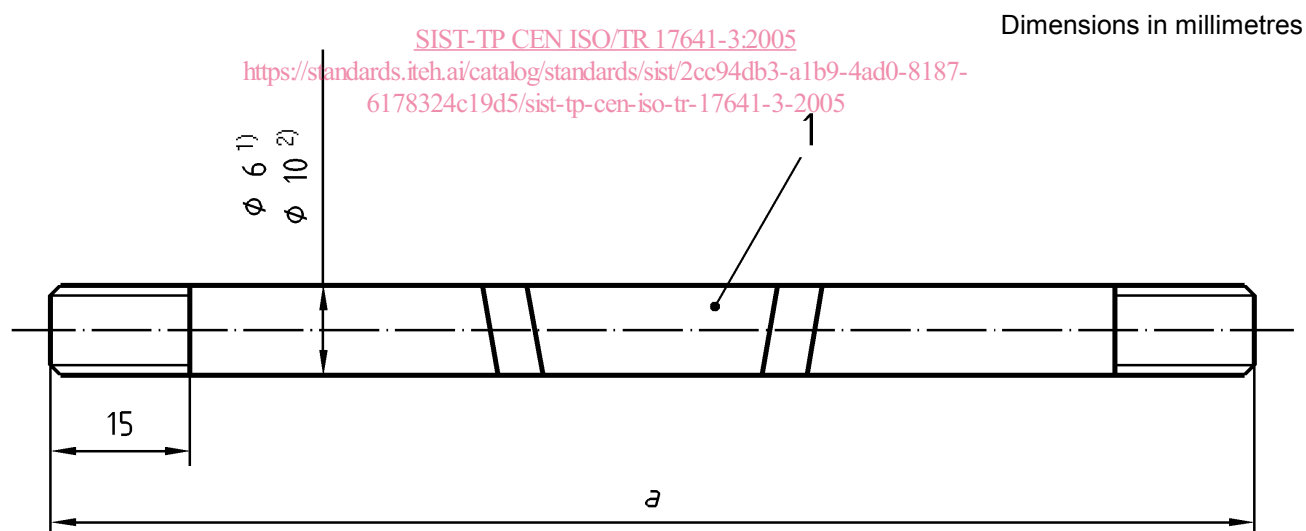

#### Key

- 1 Weld metal
- a = 130 for solidification cracking
- 110 for liquation cracking

- <sup>1)</sup> for liquation cracking
- <sup>2)</sup> for solidification cracking

Figure 1 — Specimen dimensions for the hot tensile test