



**SLOVENSKI STANDARD**  
**SIST EN 16067:2012**

**01-marec-2012**

---

**Embalaža - Toge plastične posode - PET-grla 26,7 (navoj 9,00)**

Packaging - Rigid plastic containers - PET finish 26,7 (lead 9,00)

Verpackung - Kunststoffbehältnisse - PET-Verschlussmundstück 26,7 (Gewindesteigung 9,00)

Emballage - Récipients en plastique rigide - Bague PET 26,7 (pas 9,00)

**ITeH STANDARD PREVIEW**  
**(standards.iteh.ai)**

**Ta slovenski standard je istoveten z: EN 16067:2011**

<https://standards.iteh.ai/catalog/standards/sist/fe4267af-5988-4515-a2d9-0e3df533f3d4/sist-en-16067-2012>

**ICS:**

55.100      Steklenice. Lonci. Kozarci      Bottles. Pots. Jars

**SIST EN 16067:2012**

**en,fr,de**

**iTeh STANDARD PREVIEW**  
**(standards.iteh.ai)**

SIST EN 16067:2012

<https://standards.iteh.ai/catalog/standards/sist/fe4267af-5988-4515-a2d9-0e3df533f3d4/sist-en-16067-2012>

EUROPEAN STANDARD

**EN 16067**

NORME EUROPÉENNE

EUROPÄISCHE NORM

November 2011

ICS 55.100

English Version

**Packaging - Rigid plastic containers - PET finish 26,7 (lead 9,00)**Emballage - Récipients en plastique rigide - Bague PET  
26,7 (pas 9,00)Verpackung - Kunststoffbehältnisse - PET-  
Verschlussmundstück 26,7 (Gewindesteigung 9,00)

This European Standard was approved by CEN on 29 October 2011.

CEN members are bound to comply with the CEN/CENELEC Internal Regulations which stipulate the conditions for giving this European Standard the status of a national standard without any alteration. Up-to-date lists and bibliographical references concerning such national standards may be obtained on application to the CEN-CENELEC Management Centre or to any CEN member.

This European Standard exists in three official versions (English, French, German). A version in any other language made by translation under the responsibility of a CEN member into its own language and notified to the CEN-CENELEC Management Centre has the same status as the official versions.

CEN members are the national standards bodies of Austria, Belgium, Bulgaria, Croatia, Cyprus, Czech Republic, Denmark, Estonia, Finland, France, Germany, Greece, Hungary, Iceland, Ireland, Italy, Latvia, Lithuania, Luxembourg, Malta, Netherlands, Norway, Poland, Portugal, Romania, Slovakia, Slovenia, Spain, Sweden, Switzerland and United Kingdom.

SIST EN 16067:2012

<https://standards.iteh.ai/catalog/standards/sist/fe4267af-5988-4515-a2d9-0e3df533f3d4/sist-en-16067-2012>



EUROPEAN COMMITTEE FOR STANDARDIZATION  
COMITÉ EUROPÉEN DE NORMALISATION  
EUROPÄISCHES KOMITEE FÜR NORMUNG

**Management Centre: Avenue Marnix 17, B-1000 Brussels**

<b>Contents</b>	<b>Page</b>
Foreword.....	3
Introduction .....	4
1 <b>Scope</b> .....	5
2 <b>Dimensions</b> .....	5
3 <b>Requirements</b> .....	5
Bibliography .....	7

**iTeh STANDARD PREVIEW**  
**(standards.iteh.ai)**

[SIST EN 16067:2012](https://standards.iteh.ai/catalog/standards/sist/fe4267af-5988-4515-a2d9-0e3df533f3d4/sist-en-16067-2012)

<https://standards.iteh.ai/catalog/standards/sist/fe4267af-5988-4515-a2d9-0e3df533f3d4/sist-en-16067-2012>

## Foreword

This document (EN 16067:2011) has been prepared by Technical Committee CEN/TC 261 “Packaging”, the secretariat of which is held by AFNOR.

This European Standard shall be given the status of a national standard, either by publication of an identical text or by endorsement, at the latest by May 2012, and conflicting national standards shall be withdrawn at the latest by May 2012.

Attention is drawn to the possibility that some of the elements of this document may be the subject of patent rights. CEN [and/or CENELEC] shall not be held responsible for identifying any or all such patent rights.

According to the CEN/CENELEC Internal Regulations, the national standards organizations of the following countries are bound to implement this European Standard: Austria, Belgium, Bulgaria, Croatia, Cyprus, Czech Republic, Denmark, Estonia, Finland, France, Germany, Greece, Hungary, Iceland, Ireland, Italy, Latvia, Lithuania, Luxembourg, Malta, Netherlands, Norway, Poland, Portugal, Romania, Slovakia, Slovenia, Spain, Sweden, Switzerland and the United Kingdom.

## iTeh STANDARD PREVIEW (standards.iteh.ai)

[SIST EN 16067:2012](https://standards.iteh.ai/catalog/standards/sist/fe4267af-5988-4515-a2d9-0e3df533f3d4/sist-en-16067-2012)

<https://standards.iteh.ai/catalog/standards/sist/fe4267af-5988-4515-a2d9-0e3df533f3d4/sist-en-16067-2012>

EN 16067:2011 (E)

## Introduction

This European Standard is based on CE.T.I.E. (International Technical Centre for Bottling and Packaging) data sheet GME 30.24 (2008) [1].

Efficient packaging is of great importance for the distribution and the protection of goods. Insufficient or inappropriate packaging can lead to damage or wastage of the contents of the pack.

## iTeh STANDARD PREVIEW (standards.iteh.ai)

[SIST EN 16067:2012](https://standards.iteh.ai/catalog/standards/sist/fe4267af-5988-4515-a2d9-0e3df533f3d4/sist-en-16067-2012)

<https://standards.iteh.ai/catalog/standards/sist/fe4267af-5988-4515-a2d9-0e3df533f3d4/sist-en-16067-2012>

## 1 Scope

This European Standard specifies the dimensions of the 26,7 mm screw finish with three (3) thread starts and a 16,80 mm height for flat waters and non-carbonated beverages. This finish can be used for aseptic filling and filling with introduction of nitrogen.

This finish is designed to take a tamper evident plastic closure only. During first opening, the tamper evident band will separate from the closure shell and stay on a one way bottle neck or like bottles in the returnable market, the tamper evident band will tear but will remain connected to the closure shell.

## 2 Dimensions

**2.1** The design and dimensions of the finish shall be as shown in Figure 1.

NOTE Other versions exist with  $\varnothing Z = 33$  mm max.

**2.2** Dimensions of the 3 thread starts 120° apart.

120° of full depth thread per lead

R 6,25 thread lead-in

R 6,25 thread run-out

Lead: 9 mm (travel per turn)

**2.3** General tolerance for other radii:  $\pm 0,13$  mm

**2.4** Weight on height 16,8 mm: 3,38 g (density = 1,335)

## 3 Requirements

The following requirements apply:

- This finish is a top, side and inside seal finish. This finish shall be smooth and free of any defects that will contribute to leaks. Flash shall not exceed 0,13 mm per side, and shall not be continuous.
- On the blown bottle, the control diameter C shall be free of any defects up to 4 mm down for the internal bore and across the sealing surface of the finish.
- Requirements for good closure application on finish:
  - 0,13 mm max. out-of-parallel sealing surface with neck support ledge is allowed;
  - an offset or vertical mismatch of thread is not to exceed 0,10 mm at the mould seam.  $\varnothing T$  dimension is not measured in the depressed area.
- Variations in  $\varnothing E$  are to follow uniformly those of  $\varnothing T$ .
- No overhang allowed at any point in 360° between  $\varnothing F$  and  $\varnothing G$ . A flash to 0,15 mm maximum step is allowable on one side only.  $\varnothing G$  does not exceed  $\varnothing E$ .
- In case of usage for slightly carbonated (3 g/l max.) waters and beverages, the bottler shall check that closure is suitable for this usage.

Dimensions in millimetres

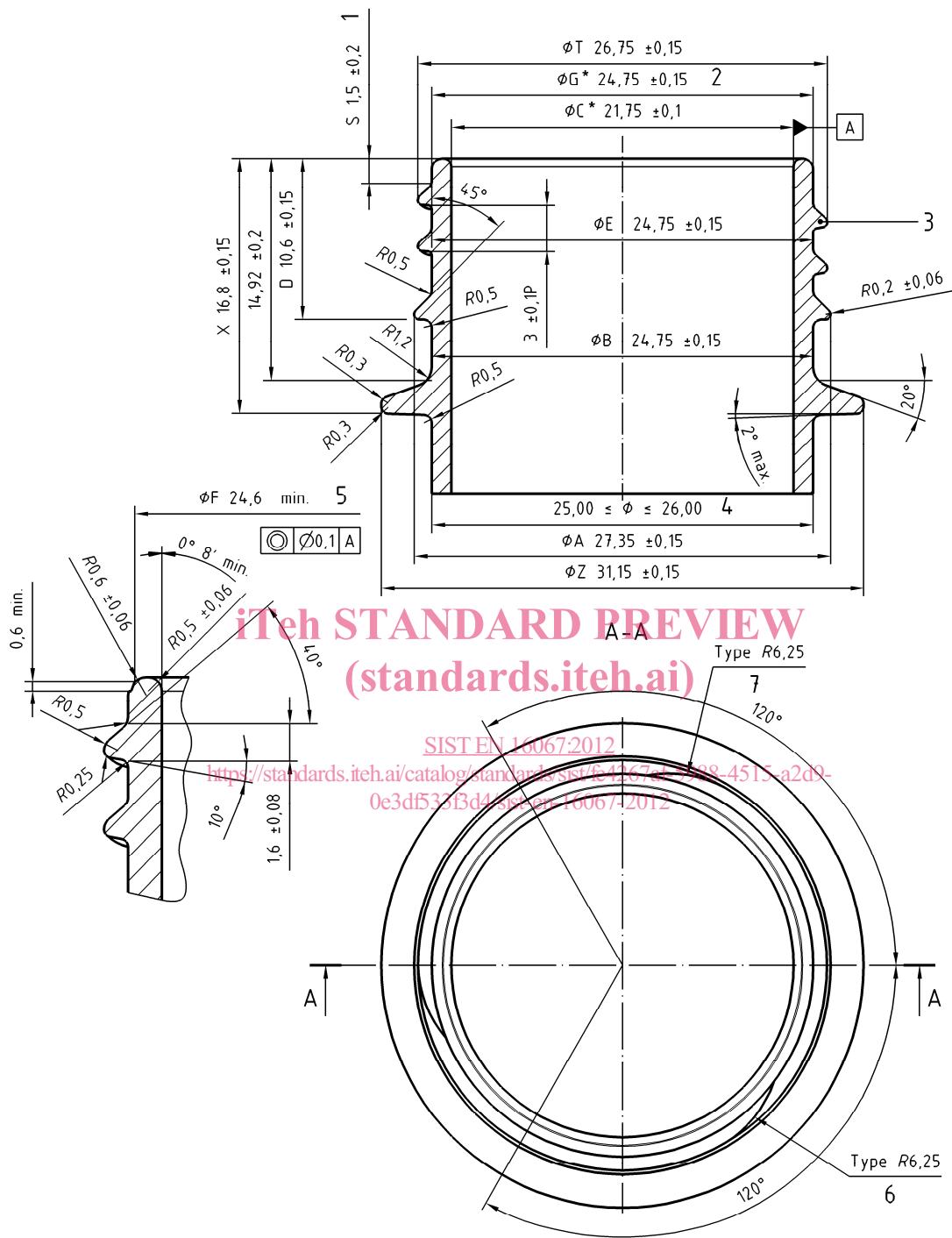

Figure 1 — Design and dimensions of the finish