INTERNATIONAL STANDARD



2346

INTERNATIONAL ORGANIZATION FOR STANDARDIZATION • МЕЖДУНАРОДНАЯ ОРГАНИЗАЦИЯ ПО СТАНДАРТИЗАЦИИ • ORGANISATION INTERNATIONALE DE NORMALISATION

Road vehicles — Compact spark plugs M 14 × 1,25 with flat seating

Véhicules routiers — Bougies d'allumage M 14 × 1,25 «compactes» à siège plat

Second edition — 1976-05-15

UDC 621.43.045

Ref. No. ISO 2346-1976 (E)

Descriptors : road vehicles, motor vehicles, internal combustion engines, ignition systems, spark plugs, dimensions, dimensional tolerances.

Price based on 4 pages

FOREWORD

ISO (the International Organization for Standardization) is a worldwide federation of national standards institutes (ISO Member Bodies). The work of developing International Standards is carried out through ISO Technical Committees. Every Member Body interested in a subject for which a Technical Committee has been set up has the right to be represented on that Committee. International organizations, governmental and non-governmental, in liaison with ISO, also take part in the work.

Draft International Standards adopted by the Technical Committees are circulated to the Member Bodies for approval before their acceptance as International Standards by the ISO Council.

International Standard ISO 2346 was drawn up by Technical Committee ISO/TC 22, *Road vehicles*. This second edition was submitted directly to the ISO Council, in accordance with clause 6.12.1 of the Directives for the technical work of ISO.

This second edition cancels and replaces the first edition (i.e. 2346-1973), which had been approved by the Member Bodies of the following countries :

| | | |
|---------------------|------------------------|-----------------------|
| Australia | Ireland | South Africa, Rep. of |
| Austria | Israel | Sweden |
| Belgium | Italy | Switzerland |
| Czechoslovakia | Japan | Thailand |
| Egypt, Arab Rep. of | Korea, Dem. P. Rep. of | Turkey |
| France | Netherlands | United Kingdom |
| Germany | Portugal | U.S.S.R. |
| Hungary | Romania | |

No Member Body had expressed disapproval of the document.

Road vehicles — Compact spark plugs M 14 × 1,25 with flat seating

1 SCOPE

This International Standard specifies the main dimensional characteristics of a spark plug type used with spark ignition engines.

2 FIELD OF APPLICATION

The provisions of this International Standard apply to compact sparks plugs M 14 × 1,25 with flat seating.

3 REFERENCES

ISO 68, *ISO general purpose screw threads — Basic profile.*

ISO 261, *ISO general purpose metric screw threads — General plan.*

ISO 965/I, *ISO general purpose metric screw threads — Tolerances — Principles and basic data.*

ISO 965/III, *ISO general purpose metric screw threads — Tolerances — Deviations for constructional threads.*

4 REQUIRED CHARACTERISTICS

4.1 Terminals (see figure 2 and annex)

The preferred type is the solid post terminal.

The threaded terminal with nut is permitted (see annex).

Engine manufacturers are encouraged to introduce solid post terminals in practice.¹⁾

4.2 Dimensions and thread (see figure 1)

4.2.1 Gasket

When the spark plugs have been tightened with a torque of 30 N·m (threads clean, smooth and dry), the gaskets shall be 1,4 to 2,0 mm in thickness. If the gaskets are of a different thickness, a corresponding adjustment to dimensions $9 \pm 0,3$, $9,5 \pm 0,2$ and 16 max. shall be made.

Non-captive gaskets may be used in special cases.

1) This recommendation will be re-examined in 3 years.

* This value for the minor diameter is given in ISO 965/III.

4.2.2 Thread

4.2.2.1 DIMENSION LIMITS

Values in millimetres

| Dimension | Plug thread (on finished plug) 6e | | Tapped hole in cylinder head 6H |
|----------------|---|---------|---------------------------------------|
| | max. | min. | |
| Major diameter | max. | 13,937 | not specified |
| | min. | 13,725 | 14,000 |
| Pitch diameter | max. | 13,125 | 13,368 |
| | min. | 12,993 | 13,188 |
| Minor diameter | max. | 12,404 | 12,912 |
| | min. | 12,181* | 12,647 |

* With a root radius $\geq 0,125$ mm (0,1 P).

4.2.2.2 TOLERANCE CLASSES

The tolerance classes of thread M 14 × 1,25 of finished spark plugs and of corresponding tapped holes in the cylinder head are as follows :

- 6e for spark plugs (see note 2);
- 6H for tapped holes in the cylinder head.

NOTES

1 The threads M 14 × 1,25 of the spark plugs and the corresponding tapped holes in the cylinder head shall conform to ISO 68, ISO 261, ISO 965/I and ISO 965/III.

2 In order that the spark plugs complying with this International Standard can be fitted in existing cylinder heads also in limiting cases, the value for the *upper limiting profile* of the minor diameter of the spark plug base has been slightly reduced with respect to the ISO value.

This maximum value of the minor diameter was calculated from a distance of $H/6$ for the *upper limiting profile* instead of $3H/16$ given in figure 6 of ISO 965/I, clause 10, according to the formula given below :

$$\begin{aligned} \text{Minor diameter max.} &= d_1 - es - 2(H/4 - H/6) \\ &= 12,647 - 0,063 - 0,180 \\ &= 12,647 - 0,243^* = 12,404 \end{aligned}$$

The value for the *basic profile* remains the same as for the ISO thread ($12,647 - 0,063 = 12,584$).

3 The initial clearance $e = 0,063$ mm between the pitch diameters of the thread and of the tapped hole is intended to prevent the possibility of seizure, as a result of combustion deposits on the bare threads, when removing the spark plugs.

This clearance is also intended to enable spark plugs with threads in accordance with this International Standard to be fitted in existing tapped holes.

4.3 Other dimensions of the spark plug and housing in the cylinder head

The other dimensions are indicated on figures 1 and 2.

NOTE — The diameter $12,2 \pm 0,5$ mm shall be complied with between dimensions 20 and 24 mm.

Details not specified are left to the manufacturer's choice.

4.4 Installation tightening torque

The maximum installation torque values apply to new spark plugs without lubricant on the threads. If threads are lubricated, the maximum torque value shall be reduced by approximately 1/3 to avoid overstressing.

The spark plugs shall be tightened with a torque of :

20 to 30 N·m in aluminium cylinder heads and

20 to 40 N·m in cast iron cylinder heads.

NOTE — Engine manufacturers may specify a different torque for the first spark plug installation.

Dimensions in millimetres

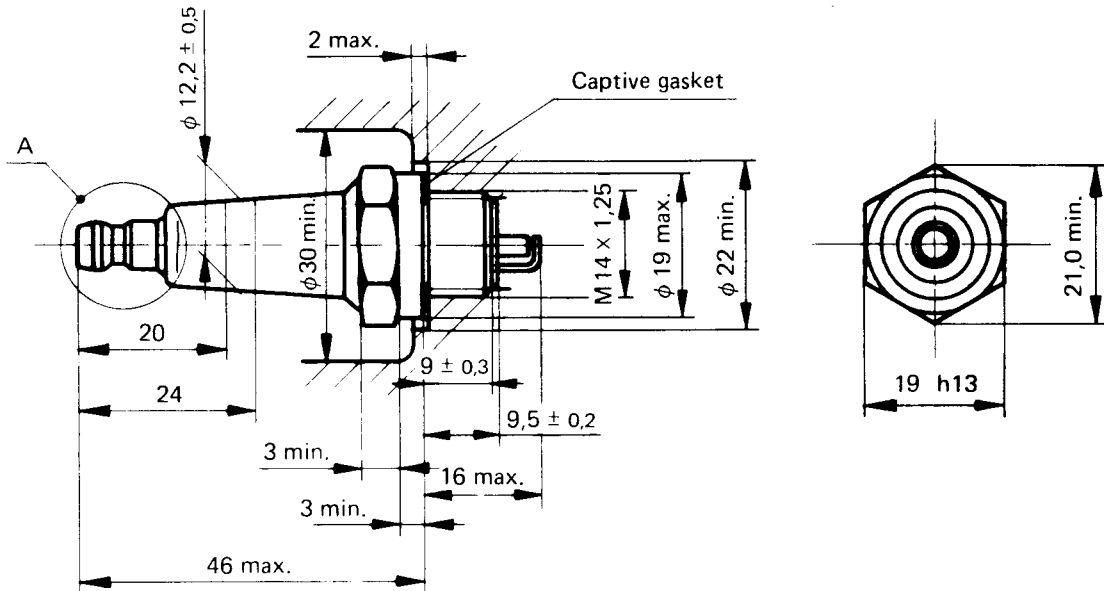

FIGURE 1 – Compact spark plug M 14 × 1,25 with flat seating

Dimensions in millimetres

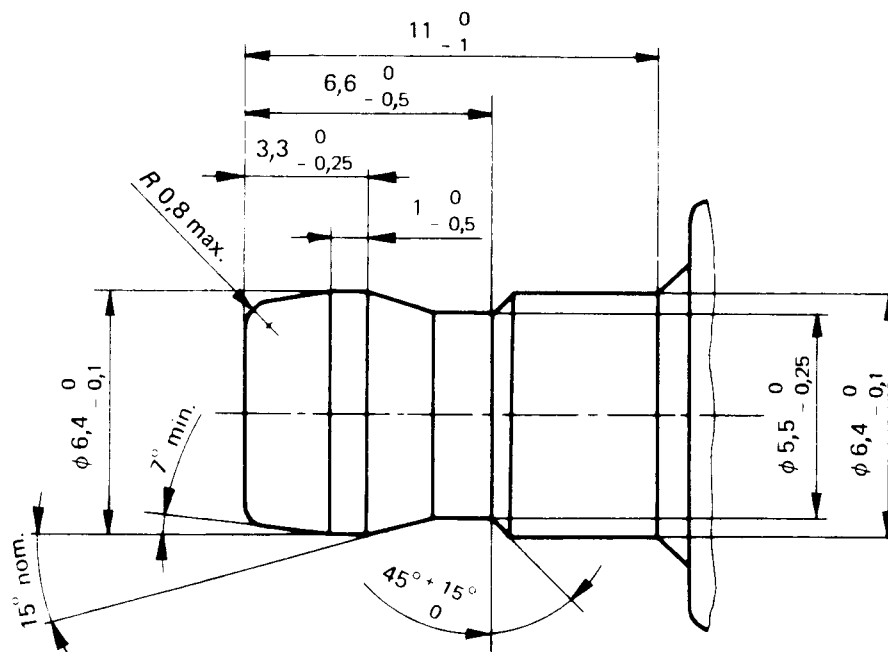

FIGURE 2 – Solid post terminal (detail A of figure 1)

ANNEX

THREADED TERMINAL

The external dimensions of the nuts shall be the same as those for the solid post terminal.

The internal dimensions of the nuts shall be left to the manufacturer's choice.

Dimensions in millimetres

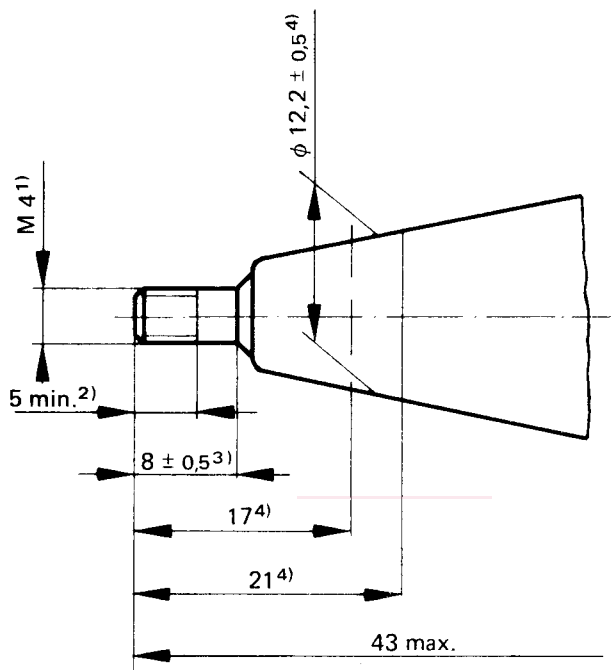

FIGURE 3 – Threaded terminal

- 1) 0,7 mm pitch complying with ISO 68 and with ISO 261.
- 2) Useful length of thread.
- 3) Cylindrical part.
- 4) The diameter $12,2 \pm 0,5$ mm shall be complied with between dimensions 17 and 21 mm.

iTeh STANDARD PREVIEW
(standards.iteh.ai)

ISO 2346:1976

<https://standards.iteh.ai/catalog/standards/sist/e37a0dbf-46f6-414c-bc35-cd42dc9d37da/iso-2346-1976>