

---

---

**Ophthalmic optics — Uncut finished  
spectacle lenses —**

**Part 1:  
Specifications for single-vision and  
multifocal lenses**

**iTeh STANDARD PREVIEW**

*Optique ophtalmique — Verres de lunettes finis non détourés —  
Partie 1. Spécifications pour les verres unifocaux et multifocaux*

[ISO 8980-1:2004](https://standards.iteh.ai/catalog/standards/sist/9ae8d827-49ef-4963-bbe0-32ddf7e347ae/iso-8980-1-2004)

<https://standards.iteh.ai/catalog/standards/sist/9ae8d827-49ef-4963-bbe0-32ddf7e347ae/iso-8980-1-2004>



**PDF disclaimer**

This PDF file may contain embedded typefaces. In accordance with Adobe's licensing policy, this file may be printed or viewed but shall not be edited unless the typefaces which are embedded are licensed to and installed on the computer performing the editing. In downloading this file, parties accept therein the responsibility of not infringing Adobe's licensing policy. The ISO Central Secretariat accepts no liability in this area.

Adobe is a trademark of Adobe Systems Incorporated.

Details of the software products used to create this PDF file can be found in the General Info relative to the file; the PDF-creation parameters were optimized for printing. Every care has been taken to ensure that the file is suitable for use by ISO member bodies. In the unlikely event that a problem relating to it is found, please inform the Central Secretariat at the address given below.

**iTeh STANDARD PREVIEW**  
**(standards.iteh.ai)**

ISO 8980-1:2004

<https://standards.iteh.ai/catalog/standards/sist/9ae8d827-49ef-4963-bbe0-32ddf7e347ae/iso-8980-1-2004>

© ISO 2004

All rights reserved. Unless otherwise specified, no part of this publication may be reproduced or utilized in any form or by any means, electronic or mechanical, including photocopying and microfilm, without permission in writing from either ISO at the address below or ISO's member body in the country of the requester.

ISO copyright office  
Case postale 56 • CH-1211 Geneva 20  
Tel. + 41 22 749 01 11  
Fax + 41 22 749 09 47  
E-mail [copyright@iso.org](mailto:copyright@iso.org)  
Web [www.iso.org](http://www.iso.org)

Published in Switzerland

**Contents**

Page

<b>Foreword</b> .....	<b>iv</b>
<b>1 Scope</b> .....	<b>1</b>
<b>2 Normative references</b> .....	<b>1</b>
<b>3 Terms and definitions</b> .....	<b>1</b>
<b>4 Classification</b> .....	<b>2</b>
<b>5 Requirements</b> .....	<b>2</b>
<b>6 Test methods</b> .....	<b>6</b>
<b>7 Identification</b> .....	<b>8</b>
<b>8 Reference to this part of ISO 8980</b> .....	<b>8</b>
<b>Annex A (informative) Material and surface quality</b> .....	<b>9</b>

**iTeh STANDARD PREVIEW**  
**(standards.iteh.ai)**

ISO 8980-1:2004

<https://standards.iteh.ai/catalog/standards/sist/9ae8d827-49ef-4963-bbe0-32ddf7e347ae/iso-8980-1-2004>

## Foreword

ISO (the International Organization for Standardization) is a worldwide federation of national standards bodies (ISO member bodies). The work of preparing International Standards is normally carried out through ISO technical committees. Each member body interested in a subject for which a technical committee has been established has the right to be represented on that committee. International organizations, governmental and non-governmental, in liaison with ISO, also take part in the work. ISO collaborates closely with the International Electrotechnical Commission (IEC) on all matters of electrotechnical standardization.

International Standards are drafted in accordance with the rules given in the ISO/IEC Directives, Part 2.

The main task of technical committees is to prepare International Standards. Draft International Standards adopted by the technical committees are circulated to the member bodies for voting. Publication as an International Standard requires approval by at least 75 % of the member bodies casting a vote.

Attention is drawn to the possibility that some of the elements of this document may be the subject of patent rights. ISO shall not be held responsible for identifying any or all such patent rights.

ISO 8980-1 was prepared by Technical Committee ISO/TC 172, *Optics and photonics*, Subcommittee SC 7, *Ophthalmic optics and instruments*.

This third edition cancels and replaces the second edition (ISO 8980-1:1996), which has been technically revised.

ISO 8980 consists of the following parts, under the general title *Ophthalmic optics — Uncut finished spectacle lenses*:

- *Part 1: Specifications for single-vision and multifocal lenses*
- *Part 2: Specifications for progressive power lenses*
- *Part 3: Transmittance specifications and test methods*
- *Part 4: Specifications and test methods for anti-reflective coatings*
- *Part 5: Minimum requirements for spectacle lenses claimed to be abrasion-resistant*

# Ophthalmic optics — Uncut finished spectacle lenses —

## Part 1: Specifications for single-vision and multifocal lenses

### 1 Scope

This part of ISO 8980 specifies requirements for the optical and geometrical properties for uncut finished single-vision and multifocal spectacle lenses.

### 2 Normative references

The following referenced documents are indispensable for the application of this document. For dated references, only the edition cited applies. For undated references, the latest edition of the referenced document (including any amendments) applies.

ISO 7944, *Optics and optical instruments — Reference wavelengths*

ISO 8429, *Optics and optical instruments — Ophthalmology — Graduated dial scale*

ISO 8598, *Optics and optical instruments — Focimeters*

ISO 13666, *Ophthalmic optics — Spectacle lenses — Vocabulary*

ISO 14889:2003, *Ophthalmic optics — Spectacle lenses — Fundamental requirements for uncut finished lenses*

### 3 Terms and definitions

For the purposes of this document, the terms and definitions given in ISO 13666 as well as the following apply.

#### 3.1

##### **focimeter, focal point on axis**

##### **FOA focimeter**

focimeter in which the focal point of the focimeter remains on the axis of the focimeter when the lens under test is measured at a point of the lens where prism is not zero

See Figure 1.

NOTE Examples of this design include all manual focusing focimeters and some automatic focimeters.

#### 3.2

##### **focimeter, infinite on axis**

##### **IOA focimeter**

focimeter in which the collimated beam coincides with the focimeter axis and the focal point of the focimeter goes off the axis of the focimeter when the lens under test is measured at a point of the lens where prism is not zero

See Figure 2.

NOTE Some automatic focimeters use this design.

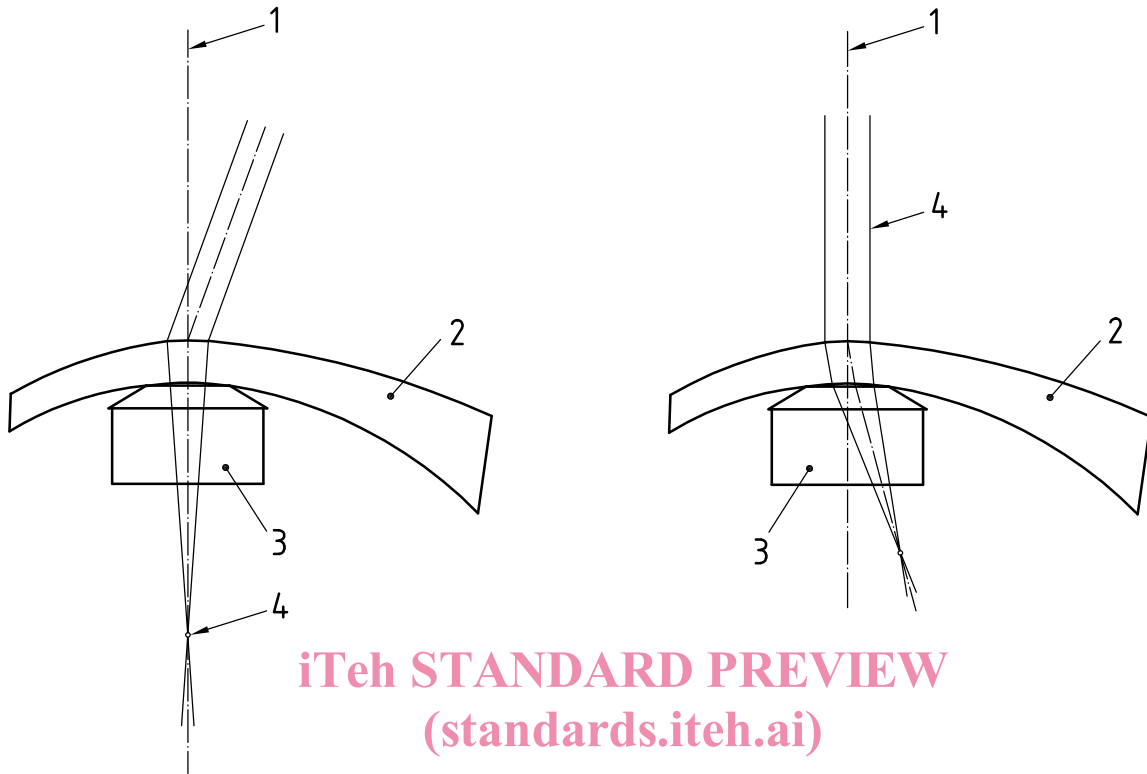

iTeh STANDARD PREVIEW  
(standards.iteh.ai)

**Key**

- 1 focimeter's optical axis
- 2 lens
- 3 focimeter lens support
- 4 focal point on the optical axis

ISO 8980-1:2004

**Key**

- 1 focimeter's optical axis
- 2 lens
- 3 focimeter lens support
- 4 infinite on the optical axis

<https://standards.iteh.ai/catalog/standards/sist/9ae8d827-49ef-4963-bbe0-32ddf7e347a1/iso-8980-1-2004>

**Figure 1 — FOA Focimeter**

**Figure 2 — IOA Focimeter**

**4 Classification**

Finished lenses are classified as follows:

- a) single-vision finished lenses;
- b) multifocal finished lenses;
- c) progressive power finished lenses.

**5 Requirements**

**5.1 General**

The tolerances shall apply at a temperature of 23 °C ± 5 °C.

## 5.2 Optical requirements

### 5.2.1 General

The optical tolerances shall apply at the reference points of the lens at one of the reference wavelengths specified in ISO 7944.

The as-worn position can result in the apparent power to the eye being different from that determined as a result of the focimeter measurement.

If the manufacturer has applied corrections to compensate for the as-worn position, then the tolerances shall apply to the corrected value and this corrected value shall be stated by the manufacturer on the package or in an accompanying document (see Clause 7).

### 5.2.2 Tolerances on the focal power of single-vision lenses and multifocal lenses for the distance portion (back vertex power)

#### 5.2.2.1 Focal power

The focal power shall be determined using a focimeter complying with ISO 8598 and using the method described in 6.2 or an equivalent method.

NOTE An ISO Technical Report is currently under preparation, which describes those parameters affecting the accuracy and inter- and intra-instruments repeatability of measurement with focimeters, both in general and in relation to off-axis measurements, e.g. the near portion of multifocal and progressive power lenses.

#### 5.2.2.2 Tolerances on the focal power of lenses

Spectacle lenses shall comply with the tolerances on the power of each principal meridian,  $A$ , and with the tolerances on the cylindrical power,  $B$  (see Table 1).

Table 1 — Tolerances on the focal power of lenses

Values in dioptres<sup>1)</sup>

Power of principal meridian with higher absolute focal power	Tolerance on the focal power of each principal meridian, $A$	Tolerance on the absolute cylindrical power $B$			
		$\geq 0,00$ and $\leq 0,75$	$> 0,75$ and $\leq 4,00$	$> 4,00$ and $\leq 6,00$	$> 6,00$
$\geq 0,00$ and $\leq 3,00$	$\pm 0,12$	$\pm 0,09$	$\pm 0,12$	$\pm 0,18$	—
$> 3,00$ and $\leq 6,00$	$\pm 0,12$	$\pm 0,12$	$\pm 0,12$	$\pm 0,18$	$\pm 0,25$
$> 6,00$ and $\leq 9,00$	$\pm 0,12$	$\pm 0,12$	$\pm 0,18$	$\pm 0,18$	$\pm 0,25$
$> 9,00$ and $\leq 12,00$	$\pm 0,18$	$\pm 0,12$	$\pm 0,18$	$\pm 0,25$	$\pm 0,25$
$> 12,00$ and $\leq 20,00$	$\pm 0,25$	$\pm 0,18$	$\pm 0,25$	$\pm 0,25$	$\pm 0,25$
$> 20,00$	$\pm 0,37$	$\pm 0,25$	$\pm 0,25$	$\pm 0,37$	$\pm 0,37$

1) Dioptres (D) can also be represented by "dpt" or "δ" and are expressed in reciprocal metres ( $m^{-1}$ ).

5.2.2.3 Tolerances on the direction of cylinder axis

The tolerances on the direction of the cylinder axis as specified in Table 2, shall be measured using the method described in 6.3. The cylinder axes shall be specified in accordance with ISO 8429.

These tolerances apply to multifocal lenses and to single-vision lenses with a predetermined orientation, e.g. prism base setting.

Table 2 — Tolerances on the direction of cylinder axis

Absolute cylindrical power D	≤ 0,50	> 0,50 and ≤ 0,75	> 0,75 and ≤ 1,50	> 1,50
Tolerance on the axis °	± 7	± 5	± 3	± 2

5.2.3 Tolerances on the addition power for multifocal lenses

The tolerances on the addition power as specified in Table 3 shall be measured using the method described in 6.5.

Table 3 — Tolerances on the addition power for multifocal lenses

Values in dioptres

Value of the addition power	≤ 4,00	> 4,00
Tolerance	± 0,12	± 0,18

ISO 8980-1:2004  
<https://standards.itech.ai/catalog/standards/sist/9ae8d827-49ef-4963-bbe0-000000000000/iso-8980-1-2004>

5.2.4 Tolerances on optical centration and prismatic power

At the distance reference point the total of prescribed prism and thickness reduction prism, where applicable, shall comply with the tolerance(s) given in Table 4 when measured using the method described in 6.4.

Table 4 — Prismatic tolerance

Values in prism dioptres

Prismatic power	Lenses		
	Single vision	Multifocal	
		Horizontal	Vertical
≥ 0,00 and ≤ 2,00	$\pm(0,25 + 0,1 \times S_{max})$	$\pm(0,25 + 0,1 \times S_{max})$	$\pm(0,25 + 0,05 \times S_{max})$
> 2,00 and ≤ 10,00	$\pm(0,37 + 0,1 \times S_{max})$	$\pm(0,37 + 0,1 \times S_{max})$	$\pm(0,37 + 0,05 \times S_{max})$
> 10,00	$\pm(0,50 + 0,1 \times S_{max})$	$\pm(0,50 + 0,1 \times S_{max})$	$\pm(0,50 + 0,05 \times S_{max})$

NOTE  $S_{max}$  is the focal power, in dioptres, in the meridian of higher absolute power.

NOTE An example of applying the above tolerances to a distance power of +0,50/-2,50 axis 20 in a multifocal prescription with a prismatic power of not greater than 2,00 Δ is as follows:

For this prescription, the principal powers are +0,50 D and -2,00 D so that the meridian of higher absolute power is 2,00 D. For a power of 2,00 D the horizontal tolerance is  $\pm(0,25 + 0,1 \times 2,00) = \pm 0,45D$ . The vertical tolerance is  $\pm(0,25 + 0,05 \times 2,00) = \pm 0,35\Delta$ .



### 5.2.5 Tolerances on the base setting of prism

The tolerances on the base setting of any prism shall be determined by verifying that the horizontal and vertical components comply with Table 4.

For a single-vision lens with prescribed astigmatic and prismatic powers, the tolerances on the difference between the cylinder axis and the prism base setting shall comply with Table 2.

## 5.3 Geometrical tolerances

### 5.3.1 Tolerances on the size of finished lenses

Lens sizes are classified as follows:

- a) nominal size ( $d_n$ ): dimension(s), in millimetres, indicated by the manufacturer;
- b) effective size ( $d_e$ ): actual dimension(s), in millimetres, of the lens;
- c) usable size ( $d_u$ ): dimension(s), in millimetres, of the area that is optically usable.

For lenses specified by diameter, the tolerances on size shall be as follows:

- 1) effective size,  $d_e$

$$d_n - 1 \text{ mm} \leq d_e \leq d_n + 2 \text{ mm}$$

- 2) usable size,  $d_u$

$$d_u \geq d_n - 2 \text{ mm}$$

STANDARD PREVIEW  
(standards.iteh.ai)

ISO 8980-1:2004

The tolerance on usable size does not apply to lenses such as lenticulars, which have a carrier curve.

32ddf7e347ae/iso-8980-1-2004

As the size and thickness of lenses worked for a particular shape and size will inevitably be subject to the requirements of the spectacle frame to be glazed, the tolerances on size and thickness are not applicable to these lenses. Such tolerances may be agreed between the prescriber and supplier.

### 5.3.2 Tolerances on thickness

The thickness shall be measured at the distance reference point of the front surface and normal to this surface. It shall not deviate from the nominal value by more than  $\pm 0,3$  mm.

The nominal thickness of the lens may be specified by the manufacturer or be agreed between the prescriber and the supplier. For lenses worked to prescription, see 5.3.1.

### 5.3.3 Tolerances on segment dimensions for multifocal lenses

When using one of the methods described in 6.6, each of the segment dimensions (width, depth and intermediate depth) shall not deviate from its nominal value by more than  $\pm 0,5$  mm.

If sold as a matched pair, each of the segment dimensions (width, depth and intermediate depth) shall not differ by more than 0,7 mm.