



# Standard Test Methods for Hookup Wire Insulation<sup>1</sup>

This standard is issued under the fixed designation D3032; the number immediately following the designation indicates the year of original adoption or, in the case of revision, the year of last revision. A number in parentheses indicates the year of last reapproval. A superscript epsilon ( $\epsilon$ ) indicates an editorial change since the last revision or reapproval.

*This standard has been approved for use by agencies of the Department of Defense.*

## 1. Scope

1.1 These test methods cover procedures for testing hookup wire.

1.2 For the purposes of these test methods, hookup wire insulation includes all components of the insulation system used on single insulated conductors or an assembly of single insulated conductors such as a cable bundle and harness or flat ribbon cable. The insulating materials include not only the primary insulation over the conductor, but also insulating jackets over shielded constructions.

1.3 The test procedures and their locations are as follows:

	Section
Axial Stability (Longitudinal Change) After Thermal Exposure	21
Bondability of Insulation to Potting Compounds	19
Capacitance	9 to 12
Cold Bend Test	26
Concentricity	16
Crush Resistance	20
Dielectric Breakdown Voltage	5
Dimensions	15
Dry-Arc Tracking	29
Dynamic Cut-Through	22
Fluid Immersion	23
High Temperature Shock	24
Insulation-Continuity Proof Tests	13
Insulation Resistance	6
Partial Discharge (Corona) Inception and Extinction Voltage	25
Relative Thermal Life and Temperature Index	14
Strip Force	27
Surface Resistance	7
Tensile Properties	17
Vertical Flame Test	18
Voltage Rating of Hook-Up Wire	A2
Voltage Withstand Test	8
Wet Arc-Tracking	28

1.4 The values stated in SI are the standard. The values given in parentheses are for information only.

1.5 *This standard does not purport to address all of the safety concerns, if any, associated with its use. It is the responsibility of the user of this standard to establish appropriate safety and health practices and determine the applica-*

*bility of regulatory limitations prior to use. For specific precaution statements, see 12.2.1, 12.4.1.8, 18.1.3 and Note 17 and 25.4.*

## 2. Referenced Documents

### 2.1 ASTM Standards:<sup>2</sup>

D149 Test Method for Dielectric Breakdown Voltage and Dielectric Strength of Solid Electrical Insulating Materials at Commercial Power Frequencies

D150 Test Methods for AC Loss Characteristics and Permittivity (Dielectric Constant) of Solid Electrical Insulation

D257 Test Methods for DC Resistance or Conductance of Insulating Materials

D374 Test Methods for Thickness of Solid Electrical Insulation

D412 Test Methods for Vulcanized Rubber and Thermoplastic Elastomers—Tension

D471 Test Method for Rubber Property—Effect of Liquids

D543 Practices for Evaluating the Resistance of Plastics to Chemical Reagents

D638 Test Method for Tensile Properties of Plastics

D1711 Terminology Relating to Electrical Insulation

D1868 Test Method for Detection and Measurement of Partial Discharge (Corona) Pulses in Evaluation of Insulation Systems

D2303 Test Methods for Liquid-Contaminant, Inclined-Plane Tracking and Erosion of Insulating Materials

D2307 Test Method for Thermal Endurance of Film-Insulated Round Magnet Wire

D2865 Practice for Calibration of Standards and Equipment for Electrical Insulating Materials Testing

D3183 Practice for Rubber—Preparation of Pieces for Test Purposes from Products

D3636 Practice for Sampling and Judging Quality of Solid Electrical Insulating Materials

D3638 Test Method for Comparative Tracking Index of Electrical Insulating Materials

<sup>1</sup> These test methods are under the jurisdiction of ASTM Committee D09 on Electrical and Electronic Insulating Materials and are the direct responsibility of Subcommittee D09.18 on Solid Insulations, Non-Metallic Shieldings and Coverings for Electrical and Telecommunication Wires and Cables.

Current edition approved April 1, 2004. Published May, 2004. Originally approved in 1972. Last previous edition approved in 1998 as D3032 – 98. DOI: 10.1520/D3032-04.

<sup>2</sup> For referenced ASTM standards, visit the ASTM website, www.astm.org, or contact ASTM Customer Service at service@astm.org. For *Annual Book of ASTM Standards* volume information, refer to the standard's Document Summary page on the ASTM website.

- [D5032 Practice for Maintaining Constant Relative Humidity by Means of Aqueous Glycerin Solutions](#)
- [D5374 Test Methods for Forced-Convection Laboratory Ovens for Evaluation of Electrical Insulation](#)
- [D5423 Specification for Forced-Convection Laboratory Ovens for Evaluation of Electrical Insulation](#)
- [D6054 Practice for Conditioning Electrical Insulating Materials for Testing](#)
- [E29 Practice for Using Significant Digits in Test Data to Determine Conformance with Specifications](#)
- [E691 Practice for Conducting an Interlaboratory Study to Determine the Precision of a Test Method](#)

## 2.2 IEEE Standards:<sup>3</sup>

**Standard 98** Guide for the Preparation of Test Procedures for the Thermal Evaluation of Electrical Insulating Materials

Standard 101 Statistical Analysis of Thermal Life Test Data

## 2.3 Federal Standard:

**Federal Specification** for Tape, Gummed; Paper, Reinforced and Plain, for Sealing and Securing (PPP-T-45C)<sup>4</sup>

## 3. Terminology

3.1 *Definitions:* For definitions of terms used in these test methods, refer to Terminology [D1711](#).

### 3.2 Definitions of Terms Specific to This Standard:

3.2.1 *capacitance unbalance (of a pair in a shielded cable), n*—the ratio, expressed as a percentage, of the difference in capacitance between each of two insulated conductors and the shield, to the capacitance between that conductor pair.

3.2.1.1 *Discussion*—Capacitance unbalance is also called coefficient of asymmetry or capacitance asymmetry, and is expressed in percent unbalance.

3.2.2 *cold bend test*—a test in which a specimen is slowly wrapped around a mandrel of a specified diameter after conditioning at a specified low temperature to determine that the primary insulation, primary jacket, overall jacket and any other layer of the wire or cable specimen maintains sufficient flexibility to withstand such bending at that low temperature without evidence of cracking.

3.2.3 *relative thermal endurance*—the comparison of the thermal endurance (as described by their Arrhenius plots) of two or more insulated wires designed for the same specific use; this usually implies the same size of conductor, but the insulation is of the thickness required for the particular use of each insulation.

3.2.4 *strip force*—force required to remove a specified length of insulation from an insulated wire specimen as determined by a specified test procedure.

3.2.5 *surface resistance, n*—see Terminology [D1711](#).

3.2.5.1 *Discussion*—For a fixed electrode separation, the measured surface resistance of a given hookup wire decreases as the diameter increases.

3.2.6 *temperature index, n*—see Terminology [D1711](#).

3.2.6.1 *Discussion*—For hookup wire, the symbol TI is used for temperature index and the preferred use of the TI symbol implies a time of 20 000 h obtained by analysis of aging data in which extrapolation is limited to no more than 25°C below the lowest aging temperature (See also Section 14).

3.2.7 *thermal end point time, n*—the time necessary for a specific property of a material, or a simple combination of materials, to degrade to a defined end point when aged at a specified temperature.

3.2.8 *thermal end point curve, n*—a graphical representation of a thermal end point at a specified aging temperature in which the value of a property of a material, or a simple combination of materials, is measured at room temperature and the values plotted as a function of time.

3.2.9 *thermal endurance, n*—see Terminology [D1711](#).

3.2.9.1 *Discussion*—The stability of hookup wire insulation is estimated from changes in the results of voltage withstand tests on hookup wire specimens that have been heat aged, cooled to room temperature, flexed over a mandrel, immersed in salt water, and subjected to a specific applied voltage.

3.2.10 *voltage withstand (proof-voltage) test*—the application of a specified voltage for a specified time to a specified configuration of the insulation. Results are expressed as “pass” or “fail.”

## 4. Sampling

4.1 Refer to the material specification for sampling plan covering specific types of hookup wire insulations.

4.2 Use Practice [D3636](#) as a guide if the material specification does not include a sampling plan.

## 5. Dielectric Breakdown Voltage

### 5.1 Significance and Use:

5.1.1 A detailed statement of significance is given in [Appendix X1](#) of Test Method [D149](#).

### 5.2 Apparatus:

5.2.1 Use the electrical apparatus described in Test Method [D149](#) for this test.

### 5.3 Test Specimens:

5.3.1 The test specimen shall consist of insulated wire 610 mm (24 in.) in length, or of the length required for the environmental exposure. Remove the insulation for a distance of 25 mm (1 in.) at each end and twist the ends together.

### 5.4 Procedure:

5.4.1 Immerse the test specimen to within 152 mm (6 in.) of the twisted ends in the water bath containing 5 % sodium chloride (NaCl) and 0.05 to 0.10 % wetting agent.<sup>5</sup>

5.4.2 Use the water solution as the ground electrode, and apply the voltage to the twisted end of the conductor.

5.4.3 Raise the voltage from zero at a rate of 500 V/s until the specimen fails. If a flashover between the water solution and the twisted ends of the wire occurs, discard the specimen without retesting. Select longer specimens so that the distance between the water solution and the ends of the wire is sufficient to prevent flashover.

<sup>3</sup> Available from the Institute of Electrical and Electronics Engineers, Inc., 345 E. 47th St., New York, NY 10017.

<sup>4</sup> Available from Standardization Documents Order Desk, Bldg. 4 Section D, 700 Robbins Ave., Philadelphia, PA 19111-5094, Attn: NPODS.

<sup>5</sup> Triton X-100 manufactured by Rohm & Haas Co., Philadelphia, PA 19106, has been found satisfactory for this test method.

### 5.5 Report:

#### 5.5.1 Report the following information:

- 5.5.1.1 Description of the specimen,
- 5.5.1.2 Voltage at which breakdown occurred,
- 5.5.1.3 Description of any previous environmental exposure given to the specimen before testing, and
- 5.5.1.4 Conditions under which the test was run.

## 6. Insulation Resistance

### 6.1 Significance and Use:

6.1.1 In high impedance circuits, insulation resistance is functionally important. In some cases, changes in insulation resistance may indicate deterioration of other properties. Insulation resistance is also useful for quality control.

NOTE 1—The term “insulation resistance” is a standard term used in the hookup wire industry to designate the resistance of a specified length of insulated wire, normally expressed as ohm-1000 ft. This is not a true insulation resistance since a resistance for a known length can be calculated and, also, the tests are conducted in a manner to eliminate surface conduction. The value obtained in this type of measurement is actually a volume resistance, but will be referred to here as insulation resistance to avoid confusion in the hookup wire industry.

### 6.2 Apparatus:

6.2.1 *Battery Jar*, or other insulated vessel, large enough to immerse the specimen, filled with water containing 0.05 to 0.10 % wetting agent.<sup>5</sup> The water bath shall serve as one electrode.

6.2.2 Use apparatus described in Test Methods **D257** for the resistance measurement.

### 6.3 Test Specimens:

6.3.1 The test specimen shall consist of a 8.3-m (or 26-ft) length of the insulated wire. Remove the insulation for a distance of 25 mm (1 in.) at each end and twist the ends together.

### 6.4 Procedure:

6.4.1 Immerse the specimen to within 152 mm (6 in.) of the twisted ends in the water bath, which is maintained at  $23 \pm 5^\circ\text{C}$  ( $73 \pm 9^\circ\text{F}$ ). Make an initial resistance measurement between the conductor and the water bath for the purpose of detecting nontypical values. Discard any specimen with a gross defect (that is, having an insulation resistance less than  $1 \times 10^6 \Omega$  between the conductor and the water bath) and replace it with another specimen.

6.4.2 After 4 h, remeasure the resistance between the conductor and the water bath. Make the measurement at 500 ( $\pm 10\%$ ) d-c V, after an electrification time of 1 min, unless otherwise specified.

### 6.5 Calculation:

6.5.1 Calculate the insulation resistance as ohm-1000 ft as follows:

$$\text{Insulation resistance, } \Omega\text{-1000 ft} = (R \times L)/1000 \quad (1)$$

where:

$R$  = measured resistance,  $\Omega$ , and

$L$  = immersed length, 25 ft.

6.5.2 Calculate the insulation resistance as  $\Omega$ -1000 m as follows:

$$\text{Insulation resistance, } \Omega\text{-1000 m} = (R \times L')/1000 \quad (2)$$

where:

$L'$  = immersed length, 8 m.

NOTE 2—Do not express insulation resistance as ohm-metre since this unit describes resistivity. It must be used as ohm for some unit of length.

### 6.6 Report:

6.6.1 Report the following information:

- 6.6.1.1 Description of the specimen,
- 6.6.1.2 Immersed length of the specimen,
- 6.6.1.3 Applied voltage,
- 6.6.1.4 Time of electrification,
- 6.6.1.5 Immersion time,
- 6.6.1.6 Measured resistance,
- 6.6.1.7 The insulation resistance of the specimen calculated in  $\Omega$ -1000 ft (or in  $\Omega$ -1000 m), and
- 6.6.1.8 Number of specimens discarded.

## 7. Surface Resistance

### 7.1 Significance and Use:

7.1.1 At high humidities, surface conduction may be responsible for the largest part of the leakage current in service (for example, at the terminations of bundled hookup wires).

7.1.2 Additional statements on the significance of surface resistance can be found in Test Methods **D257**.

### 7.2 Apparatus:

7.2.1 *Test Chamber*—A suitable test chamber can be made from a vessel fitted with a cover through which leads have been sealed. The leads can be made from polytetrafluoroethylene (PTFE)-insulated wire, sealed with paraffin wax or silicone grease as they pass through the cover. PTFE-insulated feed-through bushings can also be used in place of the wires (Fig. 1).

7.2.2 As an alternative method, a paraffin wax collar can be fitted to the top of a glass vessel and tin-coated size 1.02 mm (AWG No. 18) solid copper wires can be sealed through the paraffin wax. A glass cover can then be used to seal the top of the test chamber (Fig. 2).

7.2.3 Use the test instruments described in Test Methods **D257** for the resistance measurement.

7.2.4 The electrical resistance of the chamber, measured between the lead wires under the conditions given in 7.3 with no specimens in place, shall be greater than  $10^{12} \Omega$ .

### 7.3 Test Specimens:

7.3.1 Measure five specimens.

7.3.2 The specimens shall consist of 152-mm (6-in.) lengths of finished wire, cleaned in accordance with the procedure recommended by the manufacturer. Handle the specimens subsequently with maximum care, preferably with clean lint-free gloves to avoid even the slightest contamination, including direct contact with the fingers. Provide each cleaned specimen near its center with two electrodes spaced  $25.4 \pm 0.1$  mm ( $1.0 \pm 0.005$  in.) apart between their nearest edges. Each electrode shall be approximately 13 mm ( $\frac{1}{2}$  in.) wide, and shall consist of conductive silver paint<sup>6</sup> painted around the circumference of the specimen. Make electrical connection to the dry electrodes by wrapping several turns of fine tin-coated copper wire (0.361-mm (AWG No. 27) or finer) around the electrode,

<sup>6</sup> DuPont 4817, or equivalent, has been found satisfactory for this test method.

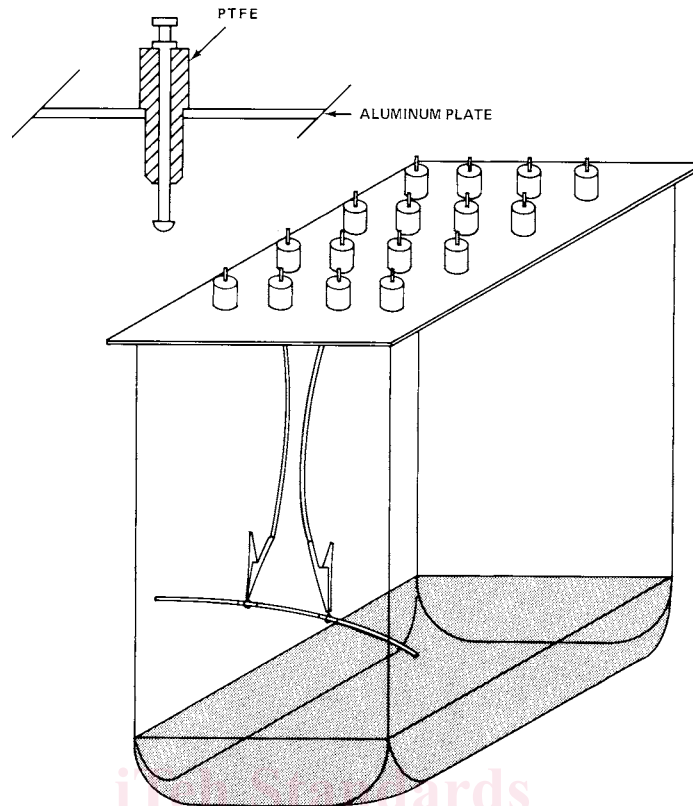

FIG. 1 Typical Surface Resistance Test Chamber Using Feed-Through Bushings

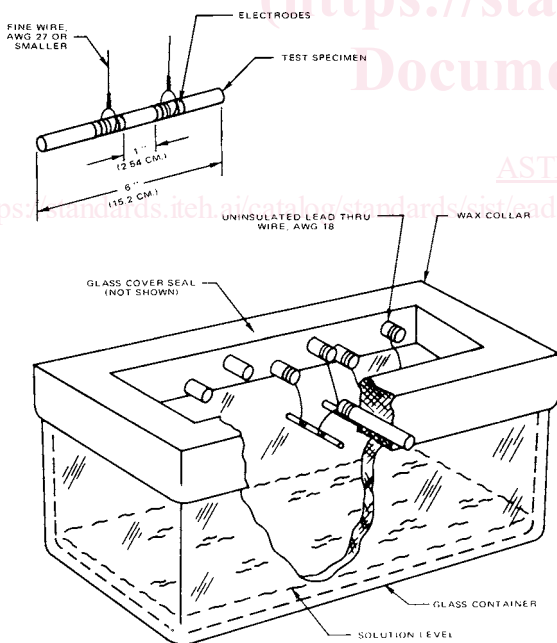

FIG. 2 Typical Surface Resistance Test Chamber Using Paraffin Wax Collar

leaving a free end of the fine wire of sufficient length for connecting to the electrical lead wires inside the test chamber.

7.4 Conditioning:

7.4.1 Measure the surface resistance after an exposure time of 96 h before removing the specimens from the test chamber.

7.4.2 Maintain the conditions in the test chamber within  $\pm 2^\circ\text{C}$  of a temperature selected in the range from 18 to  $27^\circ\text{C}$ , and within  $\pm 2\%$  relative humidity of a relative humidity selected in the range from 90 to 96 % relative humidity.

7.4.3 The relative humidity can be maintained over an aqueous glycerin solution described in Practice D5032.

NOTE 3—The allowable temperature variation for a given solution must be kept within the necessary range to maintain the relative humidity in the chamber to the required limits.

7.5 Procedure:

7.5.1 After the conditioning period stated in 7.3, measure the resistance between the electrodes after an electrification time of 1 min at 500 ( $\pm 10\%$ ) dc V.

NOTE 4—In some test methods the measured resistance is multiplied by the outside diameter of the insulation. The values so calculated should not be confused with the measured values nor with the true surface resistivity of the specimen.

7.6 Report:

7.6.1 Report the following information:

- 7.6.1.1 Description of the specimen,
- 7.6.1.2 Diameter of the specimen,
- 7.6.1.3 Test conditions (temperature and relative humidity),
- 7.6.1.4 Applied voltage, and
- 7.6.1.5 Measured surface resistance.

8. Voltage Withstand Test

8.1 Significance and Use:

8.1.1 This test method is useful as a screening test for eliminating specimens unsuitable for further testing. It can also

be used to determine whether exposure to environmental test conditions has reduced the breakdown strength below some prescribed level.

#### 8.2 Apparatus:

8.2.1 Use the electrical apparatus described in Test Method **D149** for this test.

8.2.2 *Water Bath*, containing 5 % sodium chloride (NaCl) and 0.5 to 0.10 % wetting agent.<sup>5</sup>

8.2.3 The sensitivity of the test equipment shall be such that a fault is indicated when one half of the specified test voltage is applied to the conductor of a length of 0.644-mm (AWG No. 22) stranded insulated wire whose other end, with the insulation cut flush with the conductor, is inserted 6.4 mm (¼ in.) into the test solution as far from the ground electrode as the specimen to be tested. More NaCl may be added to the solution to meet these conditions. Fault-indicating equipment is described in Test Method **D149**.

#### 8.3 Test Specimens:

8.3.1 The test specimen shall consist of insulated wire 610 mm (24 in.) in length, or of the length required for environmental exposure. Remove the insulation for a distance of 25 mm (1 in.) at each end and twist the ends together.

8.3.2 Replace any specimen having an initial gross flaw (that is, having an insulation-resistance less than  $1 \times 10^6 \Omega$  between the conductor and the solution) before exposure to environmental conditioning.

#### 8.4 Procedure:

8.4.1 Immerse the test specimen to within 51 mm (2 in.) of the twisted ends in the water solution described in **8.2.2**.

8.4.2 Measure the resistance between the conductor and the water solution at 500 ( $\pm 10$  %) dc V to detect gross flaws (8.3.2). Use the apparatus described in Test Methods **D257** for the resistance measurement.

NOTE 5—This screening test is performed before environmental exposure and is not repeated after the exposure.

8.4.3 After a 4-h soak, apply the voltage between the twisted ends of the conductor and the grounded water, increasing from zero to the specified value at a rate of 500 V/s. Hold the voltage on the specimen for 1 min, or for the time required in the applicable specification.

#### 8.5 Report:

8.5.1 Report the following information:

8.5.1.1 Description of the specimen,

8.5.1.2 Electrification time and voltage,

8.5.1.3 Description of the environmental exposure given the specimen before test,

8.5.1.4 Whether or not the specimen withstood the required voltage for the specified time,

8.5.1.5 Time for failure in case failure occurs, and

8.5.1.6 Number of specimens discarded.

### 9. Capacitance of Shielded, Single-Conductor Hookup Cable

#### 9.1 Significance and Use:

9.1.1 Capacitance per unit length is useful for quality control and is sometimes required for electronic circuit design purposes.

9.1.2 Additional statements on the significance of capacitance can be found in Test Methods **D150**.

#### 9.2 Apparatus:

9.2.1 Use the apparatus described in Test Methods **D150** for this test method.

#### 9.3 Test Specimens:

9.3.1 The specimen shall consist of a piece of shielded hookup cable approximately 3 m (10 ft) in length.

9.3.2 Remove the jacket, if any, for a distance of 25 mm (1 in.) from one end of the specimen and unbraid the shield for this distance. Remove the insulation from the conductor for a distance of 13 mm (½ in.). Twist the unbraided shield conductors together for connection to the measuring instrument and to prevent slippage of the shield on the insulation. A piece of tape over the shield can also be used to prevent slippage.

9.3.3 Terminate the opposite end of the specimen by cutting all parts of the specimen flush and perpendicular to the axis. Take care to maintain concentricity of the specimen where it is cut. Tape may be used around the shield of an unjacketed specimen to prevent slippage as long as the tape does not come in contact with the insulation or the conductor.

9.3.4 As an alternative method, both ends of the specimen can be prepared in accordance with **9.3.2**. When this is done, twist the conductors from both ends of the specimen together for connection to the measuring instrument. The shields can also be twisted together.

9.3.5 Use the distance in which the shield is in contact with the insulation as the effective length of the specimen.

#### 9.4 Procedure:

9.4.1 Connect the specimen to the measuring instrument and measure the capacitance. Subtract the capacitance of the terminals from the measured capacitance value (**Note 6**).

NOTE 6—Detailed instructions for making the measurements needed to obtain the capacitance and for making any necessary corrections due to the measuring circuit are given in the instruction books supplied with commercial equipment.

#### 9.5 Report:

9.5.1 Report the following information:

9.5.1.1 Description of the specimen,

9.5.1.2 Effective length of the specimen,

9.5.1.3 Frequency at which the measurement was made,

9.5.1.4 Temperature and relative humidity at which the measurement was made,

9.5.1.5 Measured capacitance, and

9.5.1.6 Capacitance of the specimen calculated in capacitance per foot (picofarad per foot) or capacitance per metre (picofarad per metre).

### 10. Capacitance and Capacitance Unbalance of Shielded Two-Conductor Hookup Cable

#### 10.1 Significance and Use:

10.1.1 Capacitance per unit length and capacitance unbalance are useful for quality control, and sometimes required for electronic circuit design purposes.

#### 10.2 Apparatus:

10.2.1 Use the electrical apparatus described in Test Methods **D150** for this test method.

#### 10.3 Test Specimens:

10.3.1 Prepare the specimen in accordance with 9.3, except that the insulation at one end shall be removed from both conductors for a distance of 13 mm (½ in.).

10.4 Procedure:

10.4.1 Designate one conductor as No. 1, the other conductor as No. 2, and the shield as No. 3.

10.4.2 The shield will be connected to one terminal of the measuring instrument for all three measurements needed to determine the capacitance of this type of specimen.

10.4.3 Measure the capacitance between conductor No. 2 at one terminal of the measuring instrument and No. 1 and No. 3 at the other terminal (Note 6). This capacitance value is  $C_a$ .

10.4.4 Measure the capacitance between conductor No. 1 at one terminal and No. 2 and No. 3 at the other terminal. This capacitance value is  $C_b$ .

10.4.5 Measure the capacitance between conductors No. 1 and No. 2 at one terminal and No. 3 at the other terminal. This value of capacitance is  $C_c$ .

10.4.6 Measure the length of lay of the twisted pair after the shield has been removed. The lay of the helically wound insulated conductors is the axial length of one turn of the helix.

10.5 Calculation:

10.5.1 Calculate the capacitance between the two conductors,  $C$ , as follows:

$$C = [(2(C_a + C_b) - C_c)/4] - [(C_a - C_b)^2/4 C_c] \quad (3)$$

NOTE 7—The second term of this equation is frequently neglected when the difference between  $C_a$  and  $C_b$  is small.

10.5.2 Calculate the percent capacitance unbalance as follows:

$$\text{Capacitance unbalance, \%} = [(C_a - C_b)/C] \times 100 \quad (4)$$

10.6 Report:

10.6.1 Report the following information:

10.6.1.1 Description of the specimen,

10.6.1.2 Effective length of the specimen,

10.6.1.3 Frequency at which the measurements were made,

10.6.1.4 Temperature and relative humidity at which the measurements were made,

10.6.1.5 Capacitance measured in 10.4.3,  $C_a$ ,

10.6.1.6 Capacitance measured in 10.4.4,  $C_b$ ,

10.6.1.7 Capacitance measured in 10.4.5,  $C_c$ ,

10.6.1.8 Capacitance calculated in 10.5.1,

10.6.1.9 Capacitance between the two conductors, picofarad per foot (capacitance per foot) or picofarad per metre (capacitance per metre).

10.6.1.10 Length of lay of the twisted pair after the shield has been removed in metres or inches, and

NOTE 8—Lay is sometimes expressed in twists per metre or twists per foot.

10.6.1.11 Capacitance unbalance calculated in 10.5.2.

11. Capacitance of Unshielded Twisted Pair Hookup Wire

11.1 Significance and Use:

11.1.1 Capacitance per unit length is useful for quality control and is sometimes required for electronic circuit design purposes.

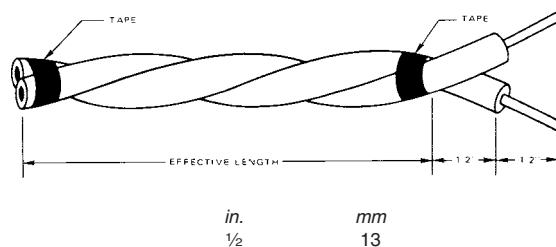

FIG. 3 Effective Specimen Length

11.2 Apparatus:

11.2.1 Use the electrical apparatus described in Test Methods D150 for this test method.

11.3 Test Specimens:

11.3.1 The specimen shall consist of a piece of twisted pair hookup wire approximately 3 m (10 ft) in length.

11.3.2 Remove the jacket, if any, for a distance of 25 mm (1 in.), or tape the wires together 1 in. back from one end of the twisted pair. Remove 13 mm (½ in.) of the insulation from both conductors.

11.3.3 If the sample is not jacketed, tape the other end of the specimen to prevent the wires from untwisting during measurement.

11.3.4 The length that the two wires are in contact will be used as the effective specimen length (Fig. 3).

11.4 Procedure:

11.4.1 Suspend the uncoiled specimen at least 0.9 m (3 ft) away from possible ground planes, such as work benches, table tops, floors, etc. Any insulating material can be used to hang the specimen in the appropriate position.

11.4.2 Connect the specimen to the measuring instrument and measure the capacitance. Subtract the capacitance of the terminals from the measured capacitance value (Note 5).

11.4.3 Measure the length of lay of the twisted pair. The lay of the helically wound insulated conductor is the axial length of one turn of the helix.

NOTE 9—The capacitance of twisted pair hookup wire is dependent on the length of lay. Higher capacitance values will be obtained on specimens of the same material with shorter lengths of lay.

11.5 Report:

11.5.1 Report the following information:

11.5.1.1 Description of the specimen,

11.5.1.2 Effective length of the specimen,

11.5.1.3 Frequency at which the measurements were made,

11.5.1.4 Temperature and relative humidity at which the measurements were made,

11.5.1.5 Measured capacitance,

11.5.1.6 Capacitance of the specimen calculated, picofarads per foot (capacitance per foot) or picofarads per metre (capacitance per metre), and

11.5.1.7 Length of lay of the twisted pair in inches or metres (Note 9).

12. Capacitance and Dissipation Factor of Hookup Wire Insulation by the Mercury U-Tube Method

12.1 Significance and Use:

12.1.1 Capacitance per unit length and dissipation factor are useful for quality control and are sometimes required for

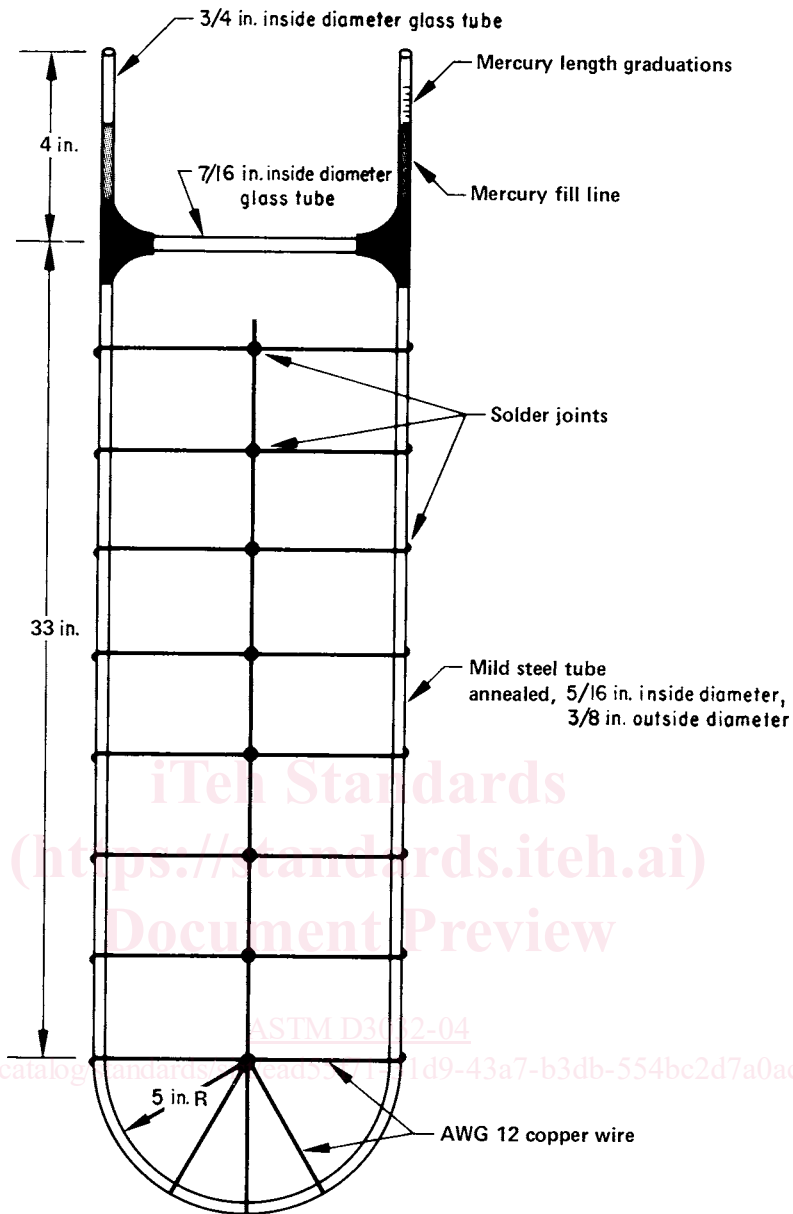

Metric Equivalents

in.	5/16	3/8	7/16	3/4	4	5	33
mm	7.94	9.53	11.11	19.05	102	127	838

FIG. 4 Mercury U-Tube Electrode System

electronic circuit design purposes. The capacitance is also needed to calculate the permittivity (dielectric constant) of an insulating material.

12.1.2 Additional statements on the significance of capacitance and dissipation factor can be found in Test Methods D150.

12.2 Apparatus:

12.2.1 *Mercury U-Tube*—A suitable mercury U-tube electrode, as shown in Fig. 4. (**Warning**—Mercury metal vapor poisoning has long been recognized as a hazard in industry. The maximum exposure limits are set by the American

Conference of Governmental Industrial Hygienist.<sup>7</sup> The concentration of mercury vapor over spills from broken thermometers, barometers, or other instruments using mercury can easily exceed these exposure limits. Mercury, being a liquid and quite heavy, will disintegrate into small droplets and seep into cracks and crevices in the floor. The use of a commercially available emergency spill kit is recommended whenever a spill occurs. The increased area of exposure adds significantly to the

<sup>7</sup> American Conference of Governmental Industrial Hygienists, Building D-7, 6500 Glenway Ave., Cincinnati, OH 45211.

mercury vapor concentration in the air. Mercury vapor concentration is easily monitored using commercially available sniffers. Spot checks should be made periodically around operations where mercury is exposed to the atmosphere. Thorough checks should be made after spills.)

12.2.2 Use apparatus described in Test Methods **D150**.

12.3 *Reagents:*

12.3.1 *Hydrochloric Acid (5+5).*

12.3.2 *Sodium Carbonate Solution.*

12.4 *Preparation of Apparatus:*

12.4.1 *Cleaning the U-Tube*—To assure low resistance contact between the steel U-tube and the mercury, clean the U-tube using the procedure given in **12.4.1.1-12.4.1.6**, as follows:

12.4.1.1 Degrease the U-tube with toluene.

12.4.1.2 Wash with cleanser and brush.

12.4.1.3 Rinse with water.

12.4.1.4 Etch for 15 min with HCl (5+5).

12.4.1.5 Neutralize with Na<sub>2</sub>CO<sub>3</sub> solution.

12.4.1.6 Rinse with hot distilled water.

12.4.1.7 Fill with mercury as soon as possible after 12.3.1.6.

12.4.1.8 There is a health hazard present due to the toxicity of mercury vapor (see **12.2.1**). Take suitable precautions during use. Cap the ends of the U-tube when they are not in use. Take care to remove and appropriately dispose of mercury that may adhere to the wire as it is removed from test.

12.5 *Calibration of U-Tube:*

12.5.1 Determine the length of the mercury in the U-tube by passing a small diameter wire or thin plastic line, that has been suitably marked off for length, through the U-tube.

12.5.2 Mark off one of the glass tubes on the top of the U-tube in 6-mm (¼-in.) intervals from the mercury fill line so that the length of specimens of different diameters can be measured.

12.6 *Test Specimens:*

12.6.1 The specimen shall consist of a piece of hookup wire of sufficient length to pass through the mercury U-tube and permit joining the ends together.

12.7 *Procedure:*

12.7.1 Cap off one end of the specimen to prevent mercury from entering the conductor when it is inserted in the U-tube.

12.7.2 Insert the specimen in the U-tube.

**NOTE 10**—A thin plastic line has been found useful for pulling the specimen through the mercury U-tube. The line is reinserted as the specimen is removed.

12.7.3 Remove the insulation for a distance of 25 mm (1 in.) from each end of the specimen and twist the free ends of the conductor together.

12.7.4 Connect the measuring instrument between the twisted ends of the specimen and the copper wire frame soldered to the U-tube.

12.7.5 Measure the capacitance and dissipation factor of the specimen (see **Note 5**).

12.7.6 Record the effective length (the length of the specimen in contact with the mercury) of the specimen obtained from the marks on the U-tube (see section 12.4.2).

12.8 *Report:*

12.8.1 Report the following information:

12.8.1.1 Description of the specimen,

12.8.1.2 Effective length of the specimen,

12.8.1.3 Frequency at which the measurement was made,

12.8.1.4 Temperature and relative humidity at which the measurement was made,

12.8.1.5 Measured capacitance,

12.8.1.6 Capacitance of the specimen calculated in picofarad per metre or picofarad per foot,

12.8.1.7 Dissipation factor of the specimen, and

12.8.1.8 Date, laboratory, and person making the measurement.

### 13. Insulation-Continuity Proof Tests

13.1 *Scope:*

13.1.1 Insulation-continuity of hookup wire may be tested by one of the following methods:

Method A (13.3)

Method B (13.8)

Repeated-Impulse Method

3000-Hz Sinusoidal-Voltage Method

13.1.2 These test methods are intended to apply primarily to the final inspection of wire for the purpose of finding and eliminating defects prior to shipment or before use.

13.1.3 These test methods are also applicable to in-process testing to eliminate defects at an early stage of manufacture (that is, for wire for use in multiple-conductor cables or jacketed constructions).

13.2 *Significance and Use:*

13.2.1 In the manufacture of hookup wire, it is desirable to have long continuous lengths. Therefore, bare wire, splices, and other defects usually are not removed until the final stages of production. The insulation-continuity proof test serves as a 100 % screening test to locate and permit the removal of all such defects either as an in-process procedure or during the final spooling operation, whichever is applicable.

13.2.2 This test method may be used as a manufacturing control test and as an acceptance test immediately prior to final packaging by the producer, or as an incoming inspection by the user. In the case of its use as an acceptance test by a user, agreement should be reached between the producer and the user as to which proof test method is mutually acceptable, and that method should be specified in the applicable product or purchase specification.

13.2.3 Possible damage in handling, degradation caused by repeated testing (each voltage test may lower the ability of the wire to withstand subsequent voltage tests), and variations in test parameters all may separately or in combination produce differences that make the comparison of results between the producer and the user difficult.

13.2.4 The insulation-continuity proof test is superior to a water-immersion test in that defects can be found and the bad sections removed during the spooling operation without damaging good insulation. Because the water bath is eliminated, the possibility of contamination of the insulated conductor is avoided.

13.3 *Apparatus*,<sup>8</sup> *Method A*—Repeated-Impulse Method:

13.3.1 *Electrode*—The electrode consists of a bead chain construction that will give intimate metallic contact with the

<sup>8</sup> The Clinton Instrument Co. manufactures the Model TT-25 Impulse Test Calibration Set for performing the single-shot test as well as for checking compliance with the requirements for capacitance tolerance and failure sensitivity.



wire insulation surface. The chain must be suspended in a U- or V-shaped trough having a width approximately 40 mm or 1 1/2 in. greater than the diameter of the largest size of wire that is tested. The chain must have a length appreciably greater than the depth of the enclosure so that the beads will droop below the wire under test. The electrode assembly consists of an array of approximately 1.6 mm or 1/16 in. diameter stainless steel bead chains suspended approximately 2.0 mm or 0.08 in. apart perpendicular to the direction of wire movement (wire line) and spaced approximately 2.5 mm or 0.10 in. apart along the wire line. The electrode length must be chosen so that at the speed being used, the wire shall be subjected to no less than 3 nor more than 100 pulses at any given point. Only one electrode will be connected to the power supply transformer. The electrode must be kept free of water and foreign matter; it must be provided with an earth grounded metal screen or equivalent guards to provide protection for the operating personnel. Broken chains must be promptly replaced as required.

13.3.2 *Power Supply*—Any impulse generator meeting the requirements of Section 13 may be used.

13.3.2.1 *Test Impulse*—The waveform of the voltage applied to the electrode head shall consist of a negative pulse, the peak magnitude of which shall be specified for the wire under test, followed by a damped oscillation. The peak impulse voltage shall be stipulated in the applicable material specification. The rise time of the negative impulse wave from zero magnitude to 90 % of the specified peak voltage shall be not more than 75  $\mu$ s. The peak value of the first positive overshoot and of the subsequent damped oscillations shall be smaller than the initial negative pulse. The time during which the absolute magnitude of each voltage pulse and accompanying damped oscillation (positive and negative) remains at a value of 80 % or greater of the specified peak voltage shall be 20 to 100  $\mu$ s. The pulse repetition rate shall be 200 to 250 pulses/s. Except for the final peak voltage adjustment (13.6) conformity with these impulse test parameters shall be determined with no capacitive load impressed on the electrode.

13.3.2.2 *Capacitive Tolerance*—The tolerance of the equipment to change in capacitive load shall be such that the peak output voltage shall be reduced by not more than 12 % in the event of an increase of the capacitive load, between electrode and ground, from an initial load of 4.9 to 9.8 pF/cm (12.5 to 25 pF/in.) of electrode length.

13.3.2.3 *Instrument Voltmeter*—A peak-reading voltmeter shall be provided, indicating continuously the potential of the electrode. The voltmeter shall have a minimum accuracy of  $\pm 3$  % at the specified impulse potential, after calibration as specified in 13.4.

13.3.2.4 *Failure Detection Circuit*—There shall be a failure detection circuit to give a visual or audible indication, or both, of insulation failure. In addition, the electrode head may be de-energized and the drive mechanism stopped. The detection circuit shall be sufficiently sensitive to indicate a fault at 75 % of the specified test voltage when the electrode is arced to ground through a 20-k $\Omega$  resistor and shall be capable of detecting a fault that lasts for the duration of only one impulse.

13.4 *Calibration*—Calibrate the instrument voltmeter periodically (see Practice D2865) by comparison with an external standard voltmeter having an accuracy of  $\pm 2$  % of the reading and capable of detecting the peak potential at the electrode head, with or without auxiliary circuitry. In performing the calibration, connect the standard voltmeter to the electrode head directly or through a calibrated attenuator circuit. Adjust the impulse generator until the reading on the standard voltmeter is the specified potential, at which point the reading on the instrument voltmeter shall be observed and recorded. Repeat this calibration for each peak potential at which it is intended to operate the equipment. An alternative procedure is by means of a calibrated oscilloscope connected to the electrode through a suitable attenuator. The peak magnitude of the negative impulse can then be read directly from the waveform display. Conformance to the other waveform parameters specified in 13.3.2.1 shall be verified from the oscilloscope.

13.5 *Test Specimens*—The test specimens consist of continuous lengths of hookup wire.

13.6 *Procedure*—Thread the wire through the electrode and ground the conductor at one, or preferably both, ends. Energize the electrode to the specified peak potential and, after final adjustment of the voltage with the wire in the electrode head, pass the wire from the pay-off spool through the electrode onto the take-up spool. The speed of passage of the wire through the electrode shall be such that, after start-up, the wire is subjected to not less than 3 nor more than 100 pulses at any given point. Cut out, or mark for later removal, all sections of wire that cause the detector to trip, along with at least 50 mm (2 in.) of wire on each side of the failure. Locate the point of failure by passing the wire back through the head. If the detector does not trip again it can be assumed that the indication was false. Make every effort to test the entire length, including ends of the wire when stringing up new lengths, in accordance with this procedure. Remove all ends or other portions of the wire not so tested. When testing wire in process, or when specified in contract or order, dielectric failures, untested portions of wire, or portions that have been exposed to fewer or more than the specified number of pulses may be marked by stripping the insulation or by any other suitable method of marking as specified in the contract in lieu of being cut out of the wire.

13.7 *Report*—If required in sales to customers the producer shall certify that 100 % of wire supplied has been tested in accordance with Section 13 of these test methods.

13.8 *Apparatus, Method B3000-Hz Sinusoidal-Voltage Method*:

13.8.1 *Electrode*—The electrode consists of a bead chain construction that will give intimate metallic contact with the wire insulation surface. The chain must be suspended in a U- or V-shaped trough having a width approximately 40 mm or 1 1/2 in. greater than the diameter of the largest wire that is tested. The chain must have a length appreciably greater than the depth of the enclosure so that the beads will droop below the wire under test. The electrode assembly consists of an array of approximately 1.6-mm or 1/16 in. diameter stainless steel bead chains suspended approximately 2.0 mm or 0.08 in. apart perpendicular to the direction of wire movement (wire line) and spaced approximately 2.5 mm or 0.10 in. apart along the

wire line. The electrode length must be chosen so that at the speed being used, the wire will be subjected to no less than a total of 18 positive and negative crests of the supply voltage (the equivalent of 9 cycles) nor more than 2000 positive or negative wave crests (1000 complete cycles) at any given cross section. Only one electrode will be connected to the power supply transformer. The electrode must be kept free of water and foreign matter; it must be provided with an earth grounded metal screen or an equivalent guard to provide protection for the operating personnel. Broken chains must be promptly replaced.

**13.8.2 Power Supply**—Any 3000-Hz sinusoidal generator meeting the requirements of **13.8.2.1** through **13.8.2.5** may be used.

**13.8.2.1 Waveform**—The waveform of the voltage applied to the electrode head shall consist of a  $3000 \pm 500$ -Hz sine wave, the amplitude of which shall be as specified for the wire under test and shall not change more than  $\pm 2\%$  as the line voltage varies  $\pm 15$  V from the nominal. Unless otherwise specified, the alternating voltage (root mean square) shall be the voltage called for in the applicable material specification. The ratio of the peak value to the root mean square value of the voltage shall be no less than 1.35 nor more than 1.48 under any load condition.

**13.8.2.2 Regulation**—The current which the equipment can deliver to a purely capacitive load shall be no less than 40 mA. The current that can be delivered to a purely resistive load shall be no less than 12 mA. When the load consists of a capacitance passing a current of 10 mA in parallel with a resistance passing a current of 1 mA the voltage at the test load shall not change more than 5 % between no-load and full-load conditions.

**13.8.2.3 Instrument Voltmeter**—An average indicating voltmeter capable of operating accurately at a frequency of up to 4000 Hz and calibrated to read root mean square values shall be provided. It shall continuously indicate the potential on the electrode. This a-c (root mean square) voltmeter, shall have an accuracy tolerance of not more than  $\pm 3\%$  at the specified potentials, after calibration as specified in **13.9.2** and shall be energized by a metering winding unity, coupled to the high-voltage secondary winding.

**13.8.2.4 Failure Detection Circuit**—There shall be a failure detection circuit to give a visual or audible indication, or both, of insulation failure. In addition, the electrode head may be de-energized and the drive mechanism stopped. The system shall be sufficiently sensitive so that a fault is indicated at 2 kV when the electrode is arced to the ground through a needle spark gap in series with the detection circuit for a duration of 0.001 s or less.

**NOTE 11**—A test set for checking sensitivity may be constructed using a turntable, with a grounded metal plate at its periphery, rotated to move the plate past a 0.13 mm (0.005 in.) phosphor bronze wire, positioned normal to the plate's surface, in 0.001 s. The wire shall be spaced 0.15 mm (0.006 in.) from the plate, and connected electrically to the output voltage of the apparatus for the duration of a single pass.

**13.8.2.5 Response After Failure Detection**—The stability and recovery of the generator and associated detection circuitry shall be such that the waveform and regulation meet the

requirements for the power supply and will maintain the set test potential 40 ms after failure detection.

#### 13.9 Calibration of Equipment:

**13.9.1** Calibrate the instrument's voltmeter periodically (see Practice **D2865**) by comparison with an external electrostatic voltmeter, with or without auxiliary circuitry, having a  $\pm 1\%$  full-scale accuracy. The measurements shall be made in the upper two-thirds of the standard voltmeter scale. In performing the calibration, connect the standard voltmeter to the electrode head directly. Adjust the voltage generator until the reading on the standard voltmeter is the specified potential, at which point the reading on the instrument's voltmeter shall be observed and recorded. Repeat this calibration for each potential at which the equipment is intended to operate.

**13.9.2** Calibration will include a determination of the waveform with the wire to be tested in the electrode. The waveform must comply with **13.8.2.1**.

#### 13.10 Test Specimens:

**13.10.1** The test specimens will consist of continuous lengths of hookup wire.

#### 13.11 Procedure:

**13.11.1** Thread the wire through the electrode and ground the conductor at one, or preferably, both ends. Energize the electrode to the specified potential and, after final adjustment of the voltage with the wire in the electrode head, pass the wire from the pay-off spool through the electrode onto the take-up spool at a speed not exceeding that used in **13.8.1** to determine the electrode length. Cut out, or mark for later removal, all sections of wire that cause the detector to trip, along with at least 2 in. of wire on each side of the failure. The point of failure can be located by passing the wire back through the head. If the detector does not trip again, it can be assumed that the indication was false. Every effort shall be made to test the entire length, including ends, of the wire when stringing up new lengths, in accordance with this procedure. Remove all ends or other portions of the wire not tested. For final testing of wire, or when specified in product or purchase specification, dielectric failures, untested portions of wire, or portions that have been exposed to fewer or more than the specified number of pulses may be marked by stripping the insulation or by any other suitable method of marking as specified in the product or purchasing specification in lieu of being cut out of the length.

#### 13.12 Report:

**13.12.1** When specified, the report shall consist of a certification that 100 % of the wire supplied has been tested in accordance with one of the methods specified in this section, at the voltage called for in the applicable product or purchasing specification. The particular method employed shall be reported.

#### 13.13 Precision and Bias:

**13.13.1** No statement is made about either the precision or the bias of these test methods for measuring insulation-continuity since the result merely states whether there is conformance to the pass/fail criteria specified in the procedure.

## 14. Relative Thermal End Point Time and Temperature Index

### 14.1 Scope:

14.1.1 This test method provides a standard test and procedure for determining thermal end point time versus temperature curves and temperature indices for flexible electrical insulating materials and insulating systems used as primary insulation and primary jackets on hookup wire whose conductor type is that used in practice.

14.2 Summary of Test Method:

14.2.1 Four sets of specimens of a given sample of insulated wire shall be exposed for selected periods of time at several fixed temperatures. After each exposure period the specimen is wrapped on a mandrel to simulate a flexing stress and then immersed in a water bath where it is given a voltage withstand test. A given specimen is subjected to a continued series of exposures at its designated test temperature until failure occurs.

14.2.2 The thermal end point time data at different temperatures are analyzed on the basis of the Arrhenius equation which relates exposure time to failure to the reciprocal of the absolute temperature of exposure. The method is based on the IEEE Standard No. 98. The preparation and processing of data are to be in general accordance with IEEE Standard 101.

14.3 Significance and Use:

14.3.1 The chemical changes that degrade the physical and electrical properties of insulation on wire are accelerated when the insulated wire is exposed to elevated operating temperatures. This test method can be used to determine the relative effects of different temperatures on the thermal end point time of a given insulating system or to compare different insulating systems at a given temperature. The times to failure in this test cannot be quantitatively related to the service life of insulating materials in actual use, but do provide a relative indication of such service life under the specific parameters of the test. The results of these shorter time tests at higher temperatures can be extrapolated to longer times at lower temperatures. The extent of any extrapolation must be limited (see 14.9). The validity of the extrapolation is based upon observed data having sufficient linearity.

14.3.1.1 Embrittlement of the insulation and the loss of its electrical strength are the usual causes of failure due to thermal exposure on insulated wire in practical applications; hence the failure points for these accelerated conditions are determined by standard tests of embrittlement and electrical strength.

14.3.1.2 In comparing different systems, it is important that the dimensions and constructions of each be those to be used in the intended application.

14.3.1.3 It is important to know that changing the condition of test will change the results. Decreasing the mandrel size, increasing weight during mandrel bend, bending too rapidly, or increasing proof voltage will decrease the thermal end point time. Too few temperature exposure cycles will result in erroneously long thermal end point time values.

14.4 Apparatus:

14.4.1 A Circulating Air Oven, for relative thermal end point time testing, meeting the general requirements of a Type II oven as specified in Specification D5423 and capable of operating at the required temperature, is required.

14.4.1.1 For absolute thermal evaluation and temperature index, the oven must fully meet the requirements of a Type II oven as specified in Specification D5423.

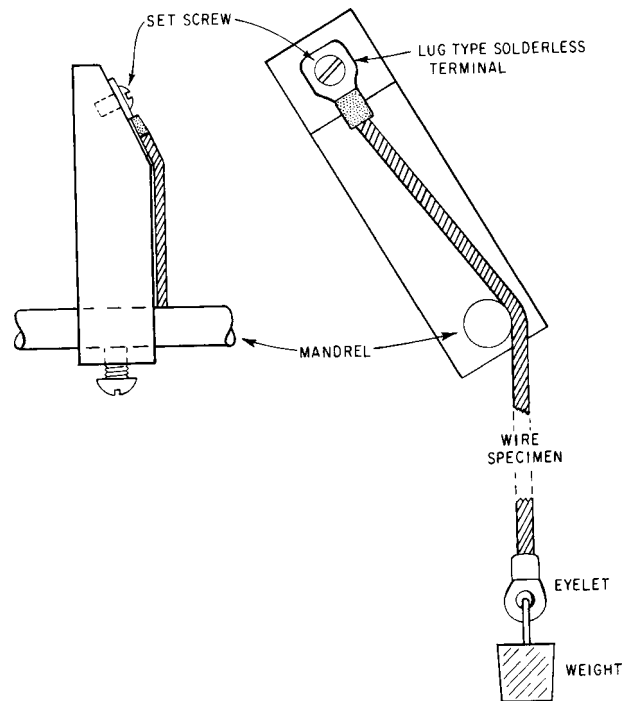

FIG. 5 Method of Attachment of Wire Test Specimen to Mandrel

14.4.1.2 The oven shall have a vertical internal dimension of at least 500 mm (20 in.).

14.4.2 Rack, for holding specimens in the oven shall be provided. A simple one can consist of 6-mm (1/4-in.) steel rods located horizontally approximately 25 mm (1 in.) below the top of the chamber. These can be mounted as a part of the chamber or as a removable rack carrying the specimens.

14.4.3 Weight with Hooks, shall be provided for holding wire specimens straight in the oven during aging. An appropriate weight size is about one-half of the mandrel test weight shown in the table in 14.4.4. It is suggested that this weight have also a hook on the bottom so that the additional weight required for the mandrel wrap can be added without removing the stabilizing weight.

14.4.4 A mandrel, shall be provided, supported horizontally, and fitted at one end with a crank for mandrel test wrapping of the specimens. Support the rod at least 6 m (2 ft) above a horizontal work surface. The mandrel shall be provided with some convenient means for attaching one end of the wire for wrapping. A suggested method of attachment is the crank arm shown in Fig. 5. The diameter of the round mandrel shall be as specified in the following table. Weights with hooks for attaching to the lower end of the specimens during the mandrel wrap shall be as follows:

Wire Size, AWG	Mandrel Diameter,		Weight, kg (lb.)	
	mm	(in.)		
20	13	(0.5)	0.7	(1.5)
14	25	(1.0)	2.7	(6.0)

It is strongly recommended that evaluations be limited to these two conductor sizes. If, however, it is necessary to use other sizes, appropriate mandrel sizes and weights are given in Appendix X1.

14.4.5 Apparatus meeting the requirements of Test Method **D149** shall be provided for performing the voltage withstand test as described in **14.7.4.4**.

#### 14.5 Sampling:

14.5.1 Samples shall consist of lengths of wire, preferably with an AWG stranded conductor, having constructions that are considered to be typical and representative of the materials to be tested. Where applicable specifications exist, it is recommended that it be determined that samples meet these requirements.

14.5.2 Each specimen preferably shall be an insulated wire with an AWG No. 20 stranded conductor; if not, all specimens of a given construction shall have the same conductor size (see **14.3.1.2**). It is recommended that the concentricity be at least 85 % since, on a mandrel test, strains and the resulting stresses can be excessive and cause premature cracking for an eccentric construction where the thicker section is remote from the mandrel.

#### 14.6 Test Specimens:

14.6.1 The conductor shall be of the construction and materials expected to be used in practice.

14.6.2 Each specimen shall be a 300 to 400-mm (12 to 16-in.) length of wire whose insulation is free of visible imperfections. It is convenient to strip approximately 6 mm (¼ in.) of insulation at each end and apply a lug from which the weights can be suspended. The lug shall be of a type that not only contacts the conductor but also clamps the insulation to prevent shrink-back with temperature exposure. Ten specimens constitute a set for thermal end point time testing at each temperature. Prepare at least four sets of specimens. It is recommended that sufficient wire be on hand for the preparation of eight sets of specimens in case the thermal end point time at some exposure temperature does not fall within the originally estimated limits.

14.6.3 It is recommended that a control insulated wire construction whose performance is known from laboratory and/or field experience, or both, be run at the same time. This requires a duplicate number of specimens as described in **14.6.2**. Two or more constructions whose performances are not known can be compared and equivalent numbers of specimens will be required for each.

#### 14.7 Procedure:

##### 14.7.1 Qualification of Laboratory Oven:

14.7.1.1 For determination of the temperature index, adjust the oven for  $150 \pm 10$  % air changes per hour. Check out oven performance as described and specified in Test Methods **D5374**.

14.7.1.2 For determination of relative thermal end point time, evaluate the adequacy of the ovens experimentally. Load the ovens with dummy test specimens that represent the normally expected loading. Attach thermocouples to a minimum of six of the dummy specimens to provide a representative sampling of the work chamber. Preferably temperatures are displayed on a multipoint recorder. Oven adequacy is determined by the temperatures obtained when the oven has stabilized. The average specimen temperature must be within

$\pm 2^\circ\text{C}$  and the maximum instantaneous deviation within  $5^\circ\text{C}$  of the desired operating temperature, regardless of the specimen location.

14.7.2 *Selection of Temperature for Test*— Select the lowest thermal test temperature by adding  $20^\circ\text{C}$  to the temperature index expected at the selected thermal end point time (10 000, 20 000, or 40 000 h). It is recommended that an additional three and preferably more be selected in  $10$  to  $20^\circ\text{C}$  successive steps. If the log average life at the highest test temperature is found to be less than 100 h, too high a test temperature has been selected and these data ought to be discarded. It is recommended that tests be repeated at a lower temperature. Extrapolation to a temperature index ought not exceed  $25^\circ\text{C}$  below the lowest thermal exposure test temperature. If extrapolation beyond  $25^\circ\text{C}$  is required, an additional series of tests shall be made at a still lower temperature. If in addition, the average thermal end point time found at the lowest test temperature is less than 5000 h, tests will be made at lower temperatures until at least 5000 h average thermal end point time data are achieved.

14.7.2.1 Make a quick estimation of the highest test temperature by running cycles of approximately one day in length at  $80$  to  $100^\circ\text{C}$  above the nominal rating temperature of the wire or at a point just below the melting point of the primary insulation if it is within this range.

14.7.2.2 Begin the test sequence with the highest temperatures since exposure times will be relatively short. On the basis of these results, review the proposed lower exposure temperatures and revise if necessary.

14.7.2.3 It is possible for the average thermal end point time of the specimens to be affected by the number of cycles. So, to maintain a consistency in the procedure that will assure a reliable degree of reproducibility, make an effort to reach an average of not less than eight and not more than fifteen cycles. A first estimate of cycle time is given in Table 3 of Test Method **D2307**. This table provides a selection of the days per cycle and the recommended aging temperatures for wires having thermal index temperatures ranging from 105 to 240. This range could be extended easily if necessary. During the course of the test, increase or decrease the length of the remaining cycles if necessary. A method for making cycle length adjustments is presented in 8.2 of Test Method **D2307**.

14.7.3 Vertically hang specimens from the mounting rack in the oven using the weights called for in **14.4.3** to keep them straight.

##### 14.7.4 Specimen Testing and Inspection:

14.7.4.1 Remove the group of specimens from the oven. Allow them to cool to room temperature. Remove the specimens from the rack.

14.7.4.2 Attach one end of the specimen to the mandrel. Hang the required additional weight on its lower end. Rotate the mandrel so that the specimen is wrapped on it, first in one direction and then in the opposite direction. Do this twice. During the wrapping, allow the wire to twist freely and seek its own position on the mandrel with the only limitation that the wire must stay in contact with the mandrel and not wind upon itself. The speed of winding shall be uniform at a rate of one turn in 3 to 5 s. It is preferable to have the winding motorized,