



SLOVENSKI STANDARD

SIST EN 353-1:2014

01-december-2014

Nadomešča:
SIST EN 353-1:2002

Osebna oprema za varovanje pred padci - Drseče naprave za zaustavljanje na vodilu, vključno s sidrnim vodilom - 1. del: Drseče naprave za zaustavljanje na vodilu, vključno s togim sidrnim vodilom

Personal fall protection equipment - Guided type fall arresters including an anchor line - Part 1: Guided type fall arresters including a rigid anchor line

iTeh STANDARD PREVIEW

Persönliche Schutzeinrichtung gegen Absturz - Mitlaufende Auffanggeräte einschließlich fester Führung - Teil 1: Mitlaufende Auffanggeräte einschließlich fester Führung

[SIST EN 353-1:2014](#)

Équipement de protection individuelle contre les chutes de hauteur - Antichutes mobiles incluant un support d'assurage - Partie 1: Antichutes mobiles incluant un support d'assurage rigide

Ta slovenski standard je istoveten z: EN 353-1:2014

ICS:

13.340.60 Zaščita pred padci in zdrsi Protection against falling and slipping

SIST EN 353-1:2014

en,fr,de

iTeh STANDARD PREVIEW
(standards.iteh.ai)

[SIST EN 353-1:2014](#)

<https://standards.iteh.ai/catalog/standards/sist/bb6e5f57-47c0-4664-bd72-aad0dc57d5f6/sist-en-353-1-2014>

EUROPEAN STANDARD

EN 353-1

NORME EUROPÉENNE

EUROPÄISCHE NORM

October 2014

ICS 13.340.60

Supersedes EN 353-1:2002

English Version

**Personal fall protection equipment - Guided type fall arresters
including an anchor line - Part 1: Guided type fall arresters
including a rigid anchor line**

Équipement de protection individuelle contre les chutes de hauteur - Antichutes mobiles incluant un support d'assurance
- Partie 1 : Antichutes mobiles incluant un support d'assurance rigide

Persönliche Schutzeinrichtung gegen Absturz - Mitlaufende Auffanggeräte einschließlich fester Führung - Teil 1: Mitlaufende Auffanggeräte einschließlich fester Führung

This European Standard was approved by CEN on 18 July 2014.

CEN members are bound to comply with the CEN/CENELEC Internal Regulations which stipulate the conditions for giving this European Standard the status of a national standard without any alteration. Up-to-date lists and bibliographical references concerning such national standards may be obtained on application to the CEN-CENELEC Management Centre or to any CEN member.

This European Standard exists in three official versions (English, French, German). A version in any other language made by translation under the responsibility of a CEN member into its own language and notified to the CEN-CENELEC Management Centre has the same status as the official versions.

CEN members are the national standards bodies of Austria, Belgium, Bulgaria, Croatia, Cyprus, Czech Republic, Denmark, Estonia, Finland, Former Yugoslav Republic of Macedonia, France, Germany, Greece, Hungary, Iceland, Ireland, Italy, Latvia, Lithuania, Luxembourg, Malta, Netherlands, Norway, Poland, Portugal, Romania, Slovakia, Slovenia, Spain, Sweden, Switzerland, Turkey and United Kingdom.



EUROPEAN COMMITTEE FOR STANDARDIZATION
COMITÉ EUROPÉEN DE NORMALISATION
EUROPÄISCHES KOMITEE FÜR NORMUNG

CEN-CENELEC Management Centre: Avenue Marnix 17, B-1000 Brussels

Contents	Page
Foreword.....	4
Introduction	5
1 Scope	6
2 Normative references	6
3 Terms and definitions	6
4 Requirements	10
4.1 Materials and construction	10
4.1.1 Materials	10
4.1.2 Construction.....	11
4.2 Static strength.....	11
4.2.1 Energy dissipating element preloading	11
4.2.2 Guided type fall arrester including rigid anchor line	11
4.2.3 Stop devices.....	12
4.3 Dynamic performance and function	12
4.3.1 General.....	12
4.3.2 Performance.....	13
4.3.3 Function.....	13
4.4 Corrosion resistance	14
4.5 Marking and information	15
5 Test methods.....	15
5.1 General examination of material and construction.....	15
5.2 Static strength.....	15
5.2.1 Energy dissipating element preloading and load bearing non-metallic elements	15
5.2.2 Guided type fall arrester including rigid anchor line	16
5.2.3 Stop devices.....	19
5.3 Dynamic performance and function tests	20
5.3.1 Apparatus	20
5.3.2 Dynamic performance	21
5.3.3 Cold condition function test.....	23
5.3.4 Minimum distance from rigid anchor line function test.....	25
5.3.5 Function test on a guiding bracket for a rigid anchor line made of wire rope	27
5.3.6 Fall back function test.....	29
5.3.7 Sideways fall function test.....	31
5.3.8 Sideways leaning anchor line function test.....	35
5.4 Corrosion resistance.....	38
6 Marking	38
7 Information supplied by the manufacturer	38
7.1 General.....	38
7.2 Installation	38
7.3 Instructions for use	39
8 Packaging	40
Annex A (informative) Explanatory information on this edition of the standard EN 353-1:2014	41
Annex B (informative) Significant technical changes between this European Standard and the previous edition EN 353-1:2002.....	43
Annex ZA (informative) Relationship between this European Standard and the Essential Requirements of EU Directive 89/686/EEC.....	45

Bibliography	47
Figures	
Figure 1 — Examples of guided type fall arresters including rigid anchor lines.....	9
Figure 2 — Illustration of installation configurations of the rigid anchor line.....	10
Figure 3 — Preloading and static strength test arrangement.....	17
Figure 4 — Static strength test arrangement for a rigid anchor line made of wire rope where the dynamic load on the top anchor exceeds 6 kN.....	18
Figure 5 — Examples of lateral load test arrangement.....	19
Figure 6 — Static strength test arrangement for stop type A.....	20
Figure 7 — Static strength test arrangement for stop type B.....	20
Figure 8 — Test arrangement for dynamic performance test for an anchor line made of rail.....	22
Figure 9 — Test arrangement for dynamic performance test for an anchor line made of wire rope.....	23
Figure 10 — Test arrangement for cold condition function test.....	25
Figure 11 — Test arrangement for minimum distance from rigid anchor line function test.....	27
Figure 12 — Test arrangement for function test on a guiding bracket for an anchor line made of wire rope.....	28
Figure 13 — Test arrangement for fall back function test for a rigid anchor line made of rail.....	30
Figure 14 — Test arrangement for fall back function test for a rigid anchor line made of wire rope.....	31
Figure 15 — Test arrangement for sideways fall function test for a rigid anchor line made of rail.....	33
Figure 16 — Test arrangement for sideways fall function test for a rigid anchor line made of wire rope.....	34
Figure 17 — Test arrangement for sideways leaning anchor line for a rigid anchor line made of rail.....	36
Figure 18 — Test arrangement for sideways leaning anchor line for a rigid anchor line made of wire rope.....	37
Tables	
Table 1 — Overview of required performance and function tests.....	13
Table A.1 — Informative explanation of the key points arising from the revision of this standard.....	41
Table B.1 — Significant technical changes.....	43
Table ZA.1 — Correspondence between this European Standard and Directive 89/686/EEC.....	45

EN 353-1:2014 (E)**Foreword**

This document (EN 353-1:2014) has been prepared by Technical Committee CEN/TC 160 "Protection against falls from height including working belts", the secretariat of which is held by DIN.

This European Standard shall be given the status of a national standard, either by publication of an identical text or by endorsement, at the latest by April 2015 and conflicting national standards shall be withdrawn at the latest by April 2015.

Attention is drawn to the possibility that some of the elements of this document may be the subject of patent rights. CEN [and/or CENELEC] shall not be held responsible for identifying any or all such patent rights.

This document will supersede EN 353-1:2002.

This document has been prepared under a mandate given to CEN by the European Commission and the European Free Trade Association, and supports essential requirements of EU Directive 89/686/EEC.

For relationship with EU Directive, see informative Annex ZA, which is an integral part of this document.

Annex B provides details of significant technical changes between this document and the previous edition EN 353-1:2002.

According to the CEN-CENELEC Internal Regulations, the national standards organizations of the following countries are bound to implement this European Standard: Austria, Belgium, Bulgaria, Croatia, Cyprus, Czech Republic, Denmark, Estonia, Finland, Former Yugoslav Republic of Macedonia, France, Germany, Greece, Hungary, Iceland, Ireland, Italy, Latvia, Lithuania, Luxembourg, Malta, Netherlands, Norway, Poland, Portugal, Romania, Slovakia, Slovenia, Spain, Sweden, Switzerland, Turkey and the United Kingdom.

[SIST EN 353-1:2014](https://standards.iteh.ai/catalog/standards/sist/bb6e5f57-47c0-4664-bd72-aad0dc57d5f6/sist-en-353-1-2014)

<https://standards.iteh.ai/catalog/standards/sist/bb6e5f57-47c0-4664-bd72-aad0dc57d5f6/sist-en-353-1-2014>

Introduction

This European Standard is intended to act as a complementary standard for existing European Standards covering other components used in personal fall protection systems.

The scope and the requirements are based on the philosophy that a guided type fall arrester including a rigid anchor line is rated to sustain the maximum dynamic load generated in a fall from a height by the mass of one person, including any equipment carried. This European Standard provides requirements and test methods for guided type fall arresters including a rigid anchor line used in personal fall protection systems in accordance with EN 363.

iTeh STANDARD PREVIEW (standards.iteh.ai)

[SIST EN 353-1:2014](https://standards.iteh.ai/catalog/standards/sist/bb6e5f57-47c0-4664-bd72-aad0dc57d5f6/sist-en-353-1-2014)

<https://standards.iteh.ai/catalog/standards/sist/bb6e5f57-47c0-4664-bd72-aad0dc57d5f6/sist-en-353-1-2014>

EN 353-1:2014 (E)**1 Scope**

This European Standard specifies the requirements, test methods, marking, information supplied by the manufacturer and packaging for guided type fall arresters including a rigid anchor line. This anchor line is usually attached to or integrated in ladders or rungs adequately fixed to suitable structures. Guided type fall arresters including a rigid anchor line conforming to this European Standard are components of one of the fall arrest systems covered by EN 363.

This European Standard applies to rigid anchor lines which are intended to be installed vertically and/or with a combination of forward-leaning angle and/or sideways leaning angle between the true vertical and the vertical +15° (see Figure 2).

Multi-user applications, i.e. rigid anchor lines that allow more than one user to be attached at any one time, are not addressed in this document.

2 Normative references

The following documents, in whole or in part, are normatively referenced in this document and are indispensable for its application. For dated references, only the edition cited applies. For undated references, the latest edition of the referenced document (including any amendments) applies.

EN 361, *Personal protective equipment against falls from a height — Full body harnesses*

EN 362, *Personal protective equipment against falls from a height — Connectors*

EN 364:1992, *Personal protective equipment against falls from a height — Test methods*

EN 365, *Personal protective equipment against falls from a height — General requirements for instructions for use, maintenance, periodic examination, repair, marking and packaging*

EN 10264-2, *Steel wire and wire products — Steel wire for ropes — Part 2: Cold drawn non alloy steel wire for ropes for general applications*

EN 13411-5, *Terminations for steel wire ropes — Safety — Part 5: U-bolt wire rope grips*

EN ISO 9227, *Corrosion tests in artificial atmospheres — Salt spray tests (ISO 9227)*

3 Terms and definitions

For the purposes of this document, the following terms and definitions apply (for examples see Figure 1).

3.1**guided type fall arrester including a rigid anchor line**

part of a fall arrest system, consisting of a guided type fall arrester and a rigid anchor line

Note 1 to entry: The guided type fall arrester and rigid anchor line form one product i.e. they are tested, certified and intended to be used together.

Note 2 to entry: An energy dissipating function may be part of the guided type fall arrester and/or the rigid anchor line.

3.2**guided type fall arrester**

device with a self-locking function, a guide facility, a connecting element for connection to the appropriate attachment element of a full body harness, which accompanies the user during both upward and downward changes in position without requiring manual adjustment and locks automatically on the anchor line when a fall occurs

3.3**rigid anchor line**

rail or tensioned wire rope fixed at both extremities and, where fitted, any terminations, brackets, joints, connectors, energy dissipating elements, tensioning elements and stop devices, intended for use with a guided type fall arrester

3.4**energy dissipating element**

element or component of a fall arrest system which is designed to dissipate the kinetic energy developed during a fall from a height

3.5**arrest distance H_{AD}**

vertical distance measured between the initial and final positions of the test mass in the dynamic performance and function tests

Note 1 to entry: Arrest distance is expressed in metres.

3.6**locking distance H_{LD}**

vertical distance measured between the initial and final positions of the guided type fall arrester in function tests

Note 1 to entry: Locking distance is expressed in metres.

3.7**connecting element**

element or combination of elements, which is a part of the guided type fall arrester, and which forms the link between the guided type fall arrester and the front attachment point of the a full body harness conforming to EN 361

SIST EN 353-1:2014

Note 1 to entry: Examples of a connecting element are a connector and/or energy dissipating element permanently attached to the guided type fall arrester.

3.8**stop device**

device fitted to the rigid anchor line to prevent the guided type fall arrester from unintentionally passing a specific point or becoming detached from the rigid anchor line

3.9**stop type A**

stop device to prevent the guided type fall arrester from unintentionally passing a specific point or becoming detached from the rigid anchor line during ascent or descent

3.10**stop type B**

stop device to prevent the guided type fall arrester from unintentionally passing a specific point or becoming detached from the rigid anchor line in a fall

Note 1 to entry: The lower termination of a rigid anchor line from wire rope can function as a stop type B.

3.11**maximum rated load**

maximum mass of the person, including tools and equipment carried, as specified by the manufacturer

Note 1 to entry: Maximum rated load is expressed in kilograms.

iTeh STANDARD PREVIEW
(standards.iteh.ai)

EN 353-1:2014 (E)**3.12****minimum rated load**

minimum mass of the person, excluding tools and equipment carried, as specified by the manufacturer

Note 1 to entry: Minimum rated load is expressed in kilograms.

3.13**bracket**

element to attach the rigid anchor line made from rail

3.14**guiding bracket**

element to guide and/or attach the rigid anchor line made from tensioned wire rope

3.15**top bracket**

element to attach the top of the rigid anchor line

3.16**bottom bracket**

element to attach the bottom of the rigid anchor line

3.17**joint**

element to connect two or more sections of the rigid anchor line

iteh STANDARD PREVIEW
(standards.iteh.ai)

[SIST EN 353-1:2014](https://standards.iteh.ai/catalog/standards/sist/bb6e5f57-47c0-4664-bd72-aad0dc57d5f6/sist-en-353-1-2014)

<https://standards.iteh.ai/catalog/standards/sist/bb6e5f57-47c0-4664-bd72-aad0dc57d5f6/sist-en-353-1-2014>

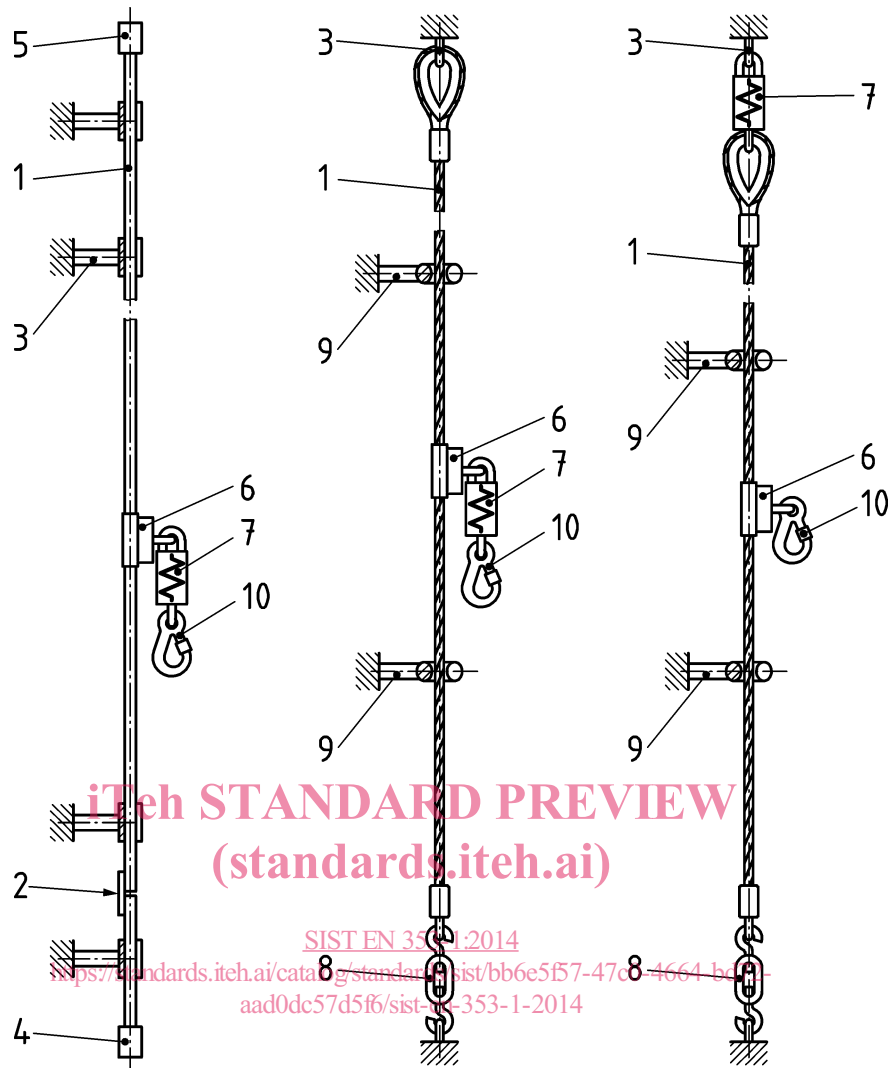

a) Example of a rigid anchor line made of rail

b) Examples of a rigid anchor line made of wire rope

Key

1	rigid anchor line	4	stop type A or B	7	energy dissipating element
2	joint	5	stop type A	8	tensioner
3	bracket	6	guided type fall arrester	9	guiding bracket
				10	connecting element

Figure 1 — Examples of guided type fall arresters including rigid anchor lines

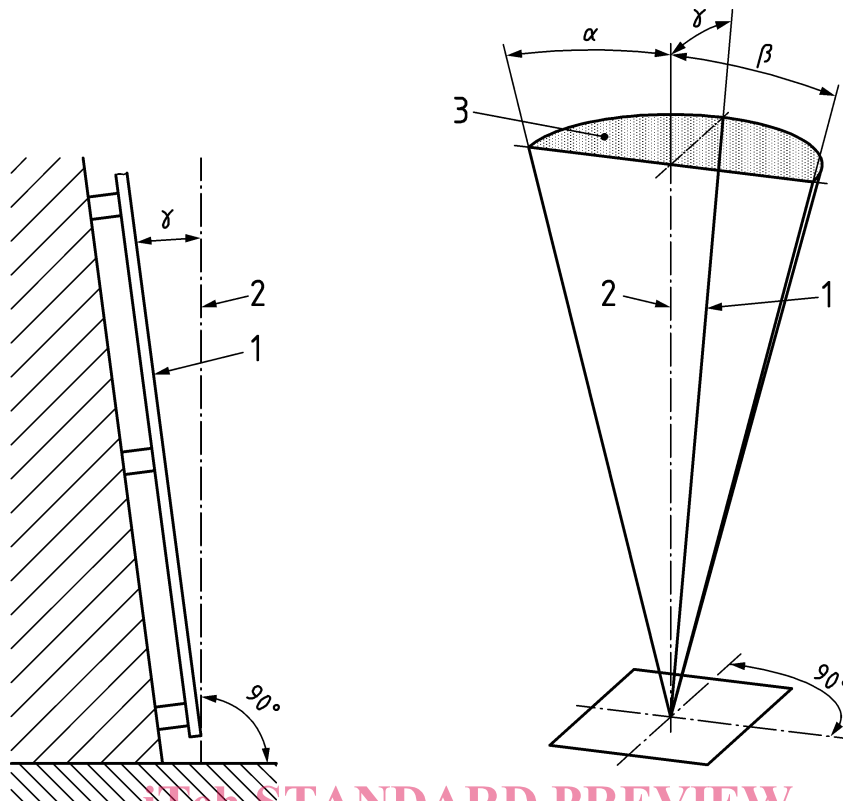
**Key**

1	rigid anchor line	α (alpha)	sideways leaning left angle (0 to 15°)
2	vertical	β (beta)	sideways leaning right angle (0 to 15°)
3	zone of possible configurations	γ (gamma)	forward leaning angle (0 to 15°)

Figure 2 — Illustration of installation configurations of the rigid anchor line

4 Requirements

4.1 Materials and construction

4.1.1 Materials

4.1.1.1 The line part of a rigid anchor line shall be made of a rail or a wire rope. Wire rope used in the manufacture of a rigid anchor line shall have a minimum nominal diameter of 8 mm and shall be made either from stainless steel or steel galvanized conforming to EN 10264-2.

4.1.1.2 Terminations (e.g. a swaged ferrule) for a rigid anchor line made from wire rope shall be made from a metallic material and not known to cause an adverse reaction with the material of the wire rope (e.g. dissimilar metal corrosion, cracking).

4.1.1.3 Connecting or energy dissipating elements from fibre ropes, webbing and sewing threads shall be made from virgin filament or multifilament synthetic fibres suitable for their intended use. The breaking tenacity of the synthetic fibres shall be known to be at least 0,6 N/tex.

4.1.1.4 Materials that may come into contact with the skin of the user shall not be known to cause irritating or sensitization effects when used as intended.

4.1.1.5 When checked in accordance with 5.1, exposed edges or corners of elements shall be relieved either with a radius of at least 0,5 mm or a chamfer of at least 0,5 mm x 45°.

4.1.2 Construction

4.1.2.1 The guided type fall arrester shall be removable from the rigid anchor line.

4.1.2.2 The guided type fall arrester including the rigid anchor line shall be so designed that unintentional separation of the guided type fall arrester from the rigid anchor line is prevented.

4.1.2.3 If the guided type fall arrester is removable by the user from the rigid anchor line other than by removing it from the ends of the rigid anchor line, the guided type fall arrester or the rigid anchor line shall be so designed that the guided type fall arrester can only be detached by at least two consecutive deliberate manual actions.

4.1.2.4 The guided type fall arrester including the rigid anchor line shall be equipped with a function(s) to prevent incorrect orientation when being fitted or attached to the rigid anchor line.

4.1.2.5 The connecting element(s) shall be permanently attached to the guided type fall arrester.

4.1.2.6 When attached to the rigid anchor line the guided type fall arrester shall be capable of accompanying the user during upward and downward changes of position without requiring manual intervention.

4.1.2.7 If a guided type fall arrester includes a non-metallic element, e.g. an energy dissipating element, this element (including end terminations) shall be protected against abrasion.

4.1.2.8 Stop devices that can be opened shall be designed so that they can only be operated by deliberate manual action, shall be self-closing and not be removable from the rigid anchor line.

4.1.2.9 Connectors used in or as a connecting element shall fulfil the requirements of EN 362 excluding subclauses 4.5 and 4.6.

4.1.2.10 U-bolt clamps including those conforming to EN 13411-5 shall not be used to form a top termination in the rigid anchor line made from wire rope.

4.2 Static strength

4.2.1 Energy dissipating element preloading

If any part of the guided type fall arrester including the rigid anchor line is fitted with an energy dissipating element, it shall be tested in accordance with 5.2.1, excluding 5.2.1.2.9. The permanent extension of the energy dissipating element after pre-loading with 2 kN shall not be greater than 20 mm.

4.2.2 Guided type fall arrester including rigid anchor line

4.2.2.1 When tested in accordance with 5.2.2.2, the guided type fall arrester including the rigid anchor line shall sustain a load of 15 kN.

4.2.2.2 If any load-bearing element, e.g. an energy dissipating element, is made from non-metallic materials and is intended to remain permanently installed, it shall sustain a load of 22 kN when tested in accordance with 5.2.1.2.9.

4.2.2.3 For rigid anchor lines made from wire rope that have been tested in accordance with 5.3.2 and have a peak load at the top anchor greater than 6 kN, the wire rope and all other elements from the top of the anchor line, e.g. an energy dissipating element, but excluding the guided type fall arrester, shall be tested in accordance with 5.2.2.3 and shall hold a load of 2,5 times the recorded peak load (permanent deformation without breaking is acceptable).

4.2.2.4 When tested in accordance with 5.2.2.4, if a guided type fall arrester cannot freely rotate around its rigid anchor line or on a guiding bracket it shall hold a lateral load of 1 kN without becoming detached