**Coal preparation — Determination of
dust/moisture relationship for coal**

*Préparation du charbon — Détermination de la relation
particules/humidité du charbon*

iTeh STANDARD PREVIEW
(standards.iteh.ai)

[SIST ISO 20905:2005](https://standards.iteh.ai/catalog/standards/sist/f396bd9f-cd1b-4b0f-98e2-f9cb0ad85c6f/sist-iso-20905-2005)

[https://standards.iteh.ai/catalog/standards/sist/f396bd9f-cd1b-4b0f-98e2-
f9cb0ad85c6f/sist-iso-20905-2005](https://standards.iteh.ai/catalog/standards/sist/f396bd9f-cd1b-4b0f-98e2-f9cb0ad85c6f/sist-iso-20905-2005)



PDF disclaimer

This PDF file may contain embedded typefaces. In accordance with Adobe's licensing policy, this file may be printed or viewed but shall not be edited unless the typefaces which are embedded are licensed to and installed on the computer performing the editing. In downloading this file, parties accept therein the responsibility of not infringing Adobe's licensing policy. The ISO Central Secretariat accepts no liability in this area.

Adobe is a trademark of Adobe Systems Incorporated.

Details of the software products used to create this PDF file can be found in the General Info relative to the file; the PDF-creation parameters were optimized for printing. Every care has been taken to ensure that the file is suitable for use by ISO member bodies. In the unlikely event that a problem relating to it is found, please inform the Central Secretariat at the address given below.

iTeh STANDARD PREVIEW
(standards.iteh.ai)

[SIST ISO 20905:2005](https://standards.iteh.ai/catalog/standards/sist/f396bd9f-cd1b-4b0f-98e2-f9cb0ad85c6f/sist-iso-20905-2005)

<https://standards.iteh.ai/catalog/standards/sist/f396bd9f-cd1b-4b0f-98e2-f9cb0ad85c6f/sist-iso-20905-2005>

© ISO 2004

All rights reserved. Unless otherwise specified, no part of this publication may be reproduced or utilized in any form or by any means, electronic or mechanical, including photocopying and microfilm, without permission in writing from either ISO at the address below or ISO's member body in the country of the requester.

ISO copyright office
Case postale 56 • CH-1211 Geneva 20
Tel. + 41 22 749 01 11
Fax + 41 22 749 09 47
E-mail copyright@iso.org
Web www.iso.org

Published in Switzerland

Contents

Page

Foreword	iv
Introduction	v
1 Scope	1
2 Normative references	1
3 Terms and definitions	1
4 Safety	1
5 Apparatus and equipment	2
6 Reagent	2
7 Sample — Initial	2
8 Sample preparation — Initial	3
8.1 Initial total moisture	3
8.2 Moisture adjustment	3
9 Sample preparation — Reagent	4
10 Dust determination	5
10.1 Environment and equipment checks	5
10.2 Dust testing	5
11 Calculation	6
12 Report	6
13 Precision	6
Annex A (informative) Worked example	7
Annex B (informative) Worksheet example	11

Foreword

ISO (the International Organization for Standardization) is a worldwide federation of national standards bodies (ISO member bodies). The work of preparing International Standards is normally carried out through ISO technical committees. Each member body interested in a subject for which a technical committee has been established has the right to be represented on that committee. International organizations, governmental and non-governmental, in liaison with ISO, also take part in the work. ISO collaborates closely with the International Electrotechnical Commission (IEC) on all matters of electrotechnical standardization.

International Standards are drafted in accordance with the rules given in the ISO/IEC Directives, Part 2.

The main task of technical committees is to prepare International Standards. Draft International Standards adopted by the technical committees are circulated to the member bodies for voting. Publication as an International Standard requires approval by at least 75 % of the member bodies casting a vote.

Attention is drawn to the possibility that some of the elements of this document may be the subject of patent rights. ISO shall not be held responsible for identifying any or all such patent rights.

ISO 20905 was prepared by Technical Committee ISO/TC 27, *Solid mineral fuels*, Subcommittee SC 1, *Coal preparation: Terminology and performance*.

iTeh STANDARD PREVIEW (standards.iteh.ai)

[SIST ISO 20905:2005](https://standards.iteh.ai/catalog/standards/sist/f396bd9f-cd1b-4b0f-98e2-f9cb0ad85c6f/sist-iso-20905-2005)

<https://standards.iteh.ai/catalog/standards/sist/f396bd9f-cd1b-4b0f-98e2-f9cb0ad85c6f/sist-iso-20905-2005>

Introduction

The development of the dust/moisture curve provides an indication of the likely response of different coal types to drying or water addition during mining and handling processes. The dust/moisture curve provides a good basis for comparing the response of different coal types. Understanding the dust/moisture characteristics of a coal will allow minimized water addition to the product for dust suppression. This will in turn assist in water conservation at mines and other handling facilities, as well as minimizing the total moisture of the product.

This International Standard describes a reliable measurement of dustiness of coal and extends to cover the relationship between dust and total moisture utilizing the Rio Tinto Dust Tumbler Test. This test provides a quantitative measure of the dustiness of a coal that can be used to predict operational dust problems, and is also suitable for the assessment of dust suppression chemicals.

The Rio Tinto Dust Tumbler Test was developed using rotating equipment in a controlled temperature and humidity environment, and uses a stream of air to remove particles which become airborne during the tumbling process. It is a batch test in which dust particles ($\sim 150 \mu\text{m}$ particles) are collected in a pre-weighed filter bag and weighed. From this mass, a dust number, calculated as the mass yield of dust multiplied by 100 000, is determined for the test total moisture. Only 1 kg of sample is required for each dust test, but eight sample lots are required to develop the dust/moisture curve for a particular coal, i.e. approximately 10 kg is required for each coal type.

This dust test can be repeated with subsamples at different coal total moisture levels to develop a dust/moisture curve. The slope of the curve provides information on how sensitive the dustiness is to changes in total moisture and a dust number of 10 has been used to provide a comparison between coals.

The test has been successfully used for several years on many coals and other bulk materials. The results have been correlated with the operating practice. The method has been applied to the evaluation of dust-control products, and the determination of dust-elimination total moisture requirements for coal-handling systems.

iTeh STANDARD PREVIEW
(standards.iteh.ai)

[SIST ISO 20905:2005](#)

<https://standards.iteh.ai/catalog/standards/sist/f396bd9f-cd1b-4b0f-98e2-f9cb0ad85c6f/sist-iso-20905-2005>

Coal preparation — Determination of dust/moisture relationship for coal

1 Scope

This International Standard sets out a laboratory procedure for the dust testing of higher rank coals. The procedure defines a means of evaluating the dust/moisture relationship characteristic of a coal and a dust extinction moisture (DEM).

NOTE In this standard, an experimental dust number of 10 has been used in the example given in Annex A.

2 Normative references

The following referenced documents are indispensable for the application of this document. For dated references, only the edition cited applies. For undated references, the latest edition of the referenced document (including any amendments) applies.

ISO 589, *Hard coal — Determination of total moisture*

ISO 1953, *Hard coal — Size analysis by sieving*

ISO 7886-1, *Sterile hypodermic syringes for single use — Part 1: Syringes for manual use*

3 Terms and definitions

For the purposes of this document, the following terms and definitions apply.

3.1

dust

particles of 150 μm or less diameter entrained in an air stream

3.2

dust extinction moisture

DEM

total moisture at which a dust number of 10 is attained on the dust/moisture curve

NOTE DEM is a useful point for comparing different coals and the effectiveness of reagents.

4 Safety

The following safety precautions shall be observed.

- a) To prevent nitrogen build-up within the laboratory, the exhaust tube of the minimum-free-space oven shall remain clear of obstruction.
- b) Safety glasses shall be worn at all times.

- c) The exhaust tube of the minimum-head-space oven shall remain free of obstruction to prevent nitrogen build-up within the laboratory.
- d) A dust mask shall be worn when handling coal.
- e) Cloth or leather gloves shall be worn when using ovens.
- f) The hazards associated with a reagent shall be determined prior to use. Instructions on all relevant Material Safety Data Sheets (MSDS) shall be followed.

5 Apparatus and equipment

The following apparatus and equipment is required.

- 5.1 **Humidity- and temperature-controlled laboratory**, with relative humidity of 63 ± 2 % and temperature of 20 ± 2 °C.
- 5.2 **Dust-test apparatus**, having a rotating drum of 30 cm diameter and 30 cm effective length, as shown in Figure 1. The required drum speed is 29 r/min, and the desired airflow through the drum is 175 L/min.
- 5.3 **Double filter bags**, single use only.
- 5.4 **Electronic thermohydrograph**.
- 5.5 **Tachometer**.
- 5.6 **Laminar flow differential-pressure manometer**.
- 5.7 **Stopwatch**.
- 5.8 **Capped bottles**, of capacity 250 mL wide mouth, polypropylene.
- 5.9 **Top loading balance**, having a minimum capacity of 1 g and readable to the nearest 0,01 g.
- 5.10 **Laboratory trays**.
- 5.11 **Minimum-free-space drying oven**.

6 Reagent

Tap water is used in solution and sample preparation.

7 Sample — Initial

Before testing, remove the particles greater than 6,3 mm. Do not crush and replace this removed fraction as the sample's particle size distribution will be altered.

Prepare sufficient sample to provide 1,2 kg for each dust determination over the desired range of total moisture or reagent concentrations as well as 1,2 kg for sample characterization. Approximately 8 subsamples, at a range of total moisture, are required to develop a dust/moisture relationship.

Once the sample has been screened, it shall be representatively split down to approximately 1,2 kg portions which are then heat-sealed in plastic bags and labelled.

One of the 1,2 kg portions is used to determine the sample's total moisture content (initial total moisture), particle size distribution as specified in ISO 1953, and other relevant characteristics. The experimental details relating to these properties shall be recorded and retained.

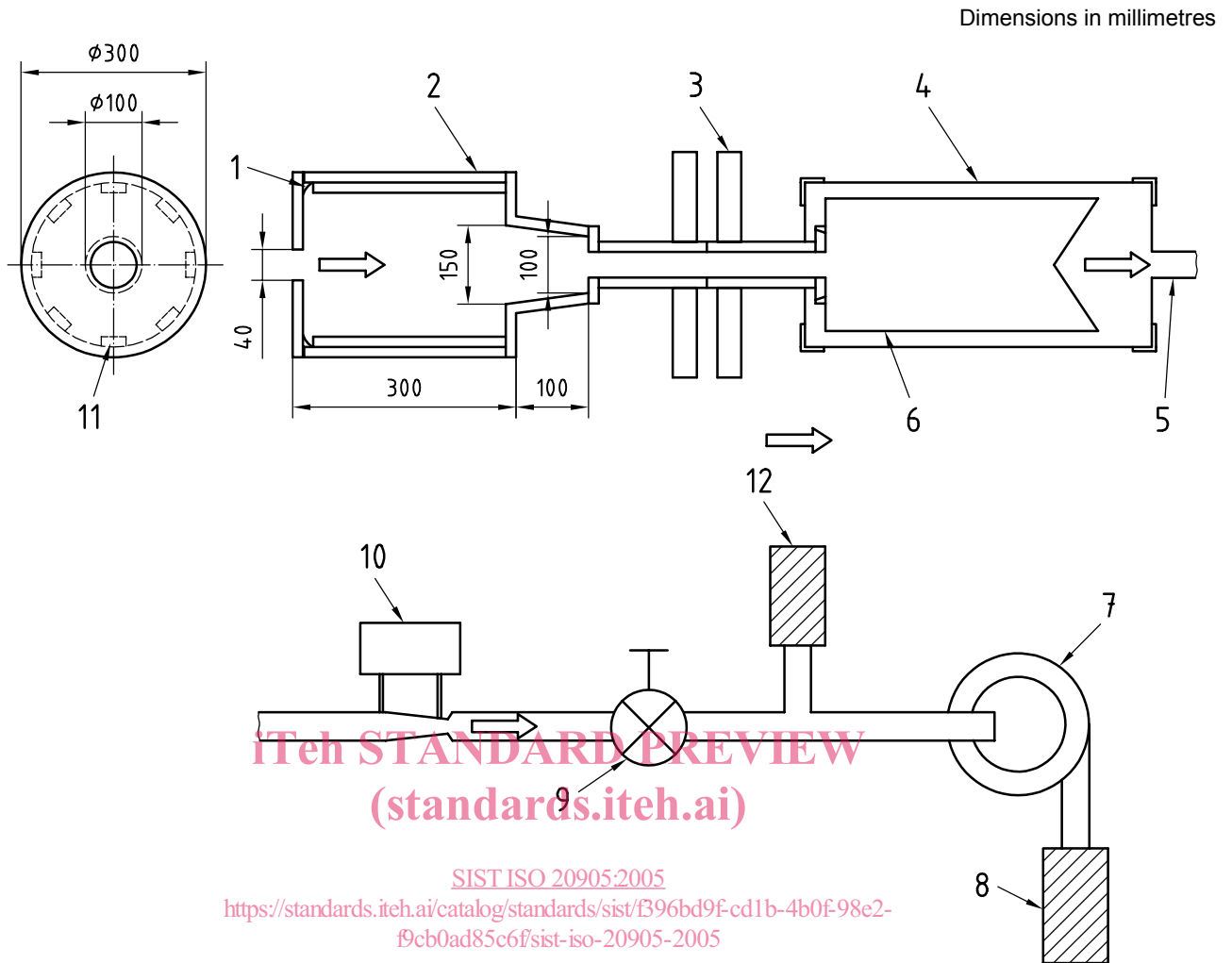
**Key**

- | | |
|---|---------------------------------|
| 1 rubber seal | 7 blower |
| 2 rotating drum | 8 muffler |
| 3 drive unit, 30 r/min | 9 valve |
| 4 sealed compartment with hinged lid for bag access | 10 flowmeter, 170 L/min |
| 5 25 mm flexible hose | 11 lifters 7 mm wide, 6 mm high |
| 6 vacuum bag | 12 intake |

Figure 1 — Dust-test apparatus**8 Sample preparation — Initial****8.1 Initial total moisture**

Determine the initial total moisture (M_1) of the sample using a subsample of the extra 1,2 kg lot, as specified in ISO 589.

8.2 Moisture adjustment

Samples are moisture adjusted to a range of total moisture contents at approximately 1 % moisture intervals. Adjust the total moisture of each of the 1,2 kg subsamples to the required level for dust testing via the following processes.

- a) For samples requiring total moisture levels greater than the initial total moisture, M_1 , water is added to the samples. Weigh the sample and calculate the mass of water required to achieve the required total moisture level using the equation below. Add the required mass of water via a spray bottle to the subsample in the plastic bag on an electronic balance. Reseal the bag and shake the bag to assist with water distribution. Leave the sample in the temperature- and humidity-controlled room (5.1) for 24 h to equilibrate. Calculate the water addition, W_a , required from the following equation:

$$W_a = m_2 - m_1$$

where

$$m_2 = m_1 \times \frac{100 - M_2}{100 - M_1}$$

where

M_1 is the initial total moisture (as measured in 8.1), expressed as a percentage;

M_2 is the required total moisture, expressed as a percentage;

m_1 is the sample mass (at M_1), in grams;

m_2 is the sample mass (at M_2), in grams;

W_a is the water addition (or removal) required.

- b) For samples requiring total moisture levels less than the initial total moisture, M_1 , water is removed by low-temperature drying. It is important that the material be evenly dried. Weigh the sample and calculate the mass of water loss required to achieve the required total moisture level, using the above equations. Place the sample in a tray in the controlled-environment laboratory and allow the sample to dry to the required mass. The tray should be weighed periodically until the required mass of water is removed. Return the sample to the plastic bag, seal and leave to equilibrate for 24 h prior to dust testing.

If the required mass loss cannot be achieved at the laboratory conditions, the sample may be dried to the required moisture level in a 40 °C oven, and then equilibrated in a sealed bag in the laboratory for 24 h.

9 Sample preparation — Reagent

Reagents can be added in addition to, or instead of, water. If the reagent is an aqueous solution, the coal sample is moisture adjusted such that the addition of reagent will increase the total moisture content to the target. Reagent doses are normally based on parts per million per mass of dry coal.

The adjusting procedure should be as follows:

- Prepare the reagent according to the manufacturer's instructions.
- Adjust the sample mass to just below total moisture required, using one of the methods described in 8.2, allowing for any water addition associated with the reagent dosing.
- Scoop and brush coal into a mixer bowl and place in a mixer.
- Weigh the final moisture addition (reagent solution), into a clean syringe in accordance with ISO 7886-1.
- Run the mixer at low speed and start the stopwatch (5.7). Dribble the final moisture and reagent onto the coal over a period of 1 min, moving the syringe around while adding.
- After 2 min, stop the mixer.

- g) Brush coal off the mixer blade and into the centre of the mixer bowl.
- h) Mix for a further 3 min.
- i) Scoop and brush the coal sample into a new labelled plastic bag, then heat-seal it.
- j) To allow the prepared sample to equilibrate, leave it in the heat-sealed bag for 24 h. The sample is then ready to dust test.

10 Dust determination

10.1 Environment and equipment checks

The following checks shall be undertaken:

- a) Ensure that the laboratory atmosphere is within the specified conditions by using the thermohydrograph (5.4).
- b) Ensure that the dust-test apparatus (5.2) is clean by blowing any residual particles from the piping and drum with compressed air.
- c) With an unused filter bag (5.3) in place, ensure that the correct quantity of air is passing through the drum. (The desired air flow is 175 L/min. This is approximately equivalent to 3,5 m/s or 12,6 km/h.)
- d) Ensure that the drum rotation speed is correct, using the tachometer (5.5) and adjusting the motor position if necessary. The required drum speed is 29 r/min.

WARNING — Care must be taken when using compressed air for cleaning purposes.

10.2 Dust testing

Complete the following for each moisture-adjusted 1,2 kg sample:

- a) Select a clean filter bag (5.3) that has been equilibrating at laboratory conditions for at least 24 h; label, record the mass on a worksheet to the nearest $\pm 0,01$ g and place it in the dust-test apparatus (5.2).

NOTE An example of a worksheet is given in Annex B.

- b) Take duplicate samples for total moisture determination.
- c) Weigh 1 000 g of a representatively taken sample and record the mass to $\pm 0,01$ g.
- d) Place the sample in the drum; ensuring that all of the sample is in the lifter part of the drum only. Replace the end plate and guard mesh.
- e) Start the fan.
- f) When the fan has reached full speed, start the drum rotating and the stopwatch.
- g) After 10 min, stop the drum motor.
- h) Allow the fan to run for a further 13 s after stopping the drum motor.
- i) Carefully, so as not to lose any dust, remove the filter bag (5.3) and record its mass. Leave the bag in a clean area of the humidity- and temperature-controlled laboratory (5.1) and reweigh after 24 h.
- j) Place a large tray (5.10) under the drum, remove the end plate and brush coal from the drum into the tray.