



# SLOVENSKI STANDARD SIST EN ISO 17642-2:2005

01-maj-2005

Dcfi ý]h Yb]dfYg\_i g]nj Ufcj `bU\_cj ]bg\_]\ `a UHf]U]\ `ÈDfYg\_i g]`bUdc\_Ub^j  
\\UXbYa `nUnj UfbYgdc^ÈCVc b]`bU ]b]j Uf^b^UÈ&rXY. DfYg\_i g'dc\_`j] cgh`bU  
dfcglc`j dYhYa `dfYg\_i ýUbW`fIGC`%+\*( &&&\$) Ł

Destructive tests on welds in metallic materials - Cold cracking tests for weldments - Arc welding processes - Part 2: Self-restraint tests (ISO 17642-2:2005)

Zerstörende Prüfung von Schweißverbindungen an metallischen Werkstoffen - Kaltrissprüfungen für Schweißungen - Lichtbogenschweißprozesse - Teil 2: Selbstbeanspruchende Prüfungen (ISO 17642-2:2005)

Essais destructifs des soudures sur matériaux métalliques - Essais de fissuration a froid des assemblages soudés - Procédés de soudage a l'arc - Partie 2: Essais sur éprouvette auto-bridée (ISO 17642-2:2005)

Ta slovenski standard je istoveten z: EN ISO 17642-2:2005

## ICS:

25.160.40 Varjeni spoji in vari Welded joints

SIST EN ISO 17642-2:2005 en

**iTeh STANDARD PREVIEW**  
**(standards.iteh.ai)**

[SIST EN ISO 17642-2:2005](https://standards.iteh.ai/catalog/standards/sist/75a9c612-a721-4cc5-a43b-b4170a90b845/sist-en-iso-17642-2-2005)

<https://standards.iteh.ai/catalog/standards/sist/75a9c612-a721-4cc5-a43b-b4170a90b845/sist-en-iso-17642-2-2005>

EUROPEAN STANDARD  
NORME EUROPÉENNE  
EUROPÄISCHE NORM

**EN ISO 17642-2**

March 2005

ICS 25.160.40

English version

**Destructive tests on welds in metallic materials - Cold cracking tests for weldments - Arc welding processes - Part 2: Self-restraint tests (ISO 17642-2:2005)**

Essais destructifs des soudures sur matériaux métalliques -  
Essais de fissuration à froid des assemblages soudés -  
Procédés de soudage à l'arc - Partie 2: Essais sur  
éprouvette auto-bridée (ISO 17642-2:2005)

Zerstörende Prüfung von Schweißverbindungen an  
metallischen Werkstoffen - Kaltrissprüfungen für  
Schweißungen - Lichtbogenschweißprozesse - Teil 2:  
Selbstbeanspruchende Prüfungen (ISO 17642-2:2005)

This European Standard was approved by CEN on 9 February 2004.

CEN members are bound to comply with the CEN/CENELEC Internal Regulations which stipulate the conditions for giving this European Standard the status of a national standard without any alteration. Up-to-date lists and bibliographical references concerning such national standards may be obtained on application to the Central Secretariat or to any CEN member.

This European Standard exists in three official versions (English, French, German). A version in any other language made by translation under the responsibility of a CEN member into its own language and notified to the Central Secretariat has the same status as the official versions.

CEN members are the national standards bodies of Austria, Belgium, Cyprus, Czech Republic, Denmark, Estonia, Finland, France, Germany, Greece, Hungary, Iceland, Ireland, Italy, Latvia, Lithuania, Luxembourg, Malta, Netherlands, Norway, Poland, Portugal, Slovakia, Slovenia, Spain, Sweden, Switzerland and United Kingdom.



EUROPEAN COMMITTEE FOR STANDARDIZATION  
COMITÉ EUROPÉEN DE NORMALISATION  
EUROPÄISCHES KOMITEE FÜR NORMUNG

**Management Centre: rue de Stassart, 36 B-1050 Brussels**

<b>Contents</b>	<b>page</b>
Foreword.....	3
<b>1 Scope</b> .....	<b>4</b>
<b>2 Normative references</b> .....	<b>4</b>
<b>3 Terms and definitions</b> .....	<b>4</b>
<b>4 Designation and symbols</b> .....	<b>5</b>
<b>5 Principle</b> .....	<b>5</b>
5.1 General.....	5
5.2 Qualitative evaluation.....	5
5.3 Quantitative evaluation .....	5
<b>6 Test</b> .....	<b>6</b>
6.1 CTS-test .....	6
6.1.1 Dimensions of the test pieces .....	6
6.1.2 Preparation of the test pieces .....	6
6.1.3 Anchor welds .....	7
6.1.4 Test welds.....	8
6.1.5 Test results .....	10
6.2 <b>TEKKEN-test (Y-groove) and Lehigh test (U-groove)</b> .....	<b>12</b>
6.2.1 General.....	12
6.2.2 Dimensions of the test pieces .....	12
6.2.3 Preparation of the test pieces .....	14
6.2.4 Anchor welds .....	14
6.2.5 Test welds.....	14
6.2.6 Test results.....	16
<b>7 Test report (CTS, Y and U groove)</b> .....	<b>19</b>
<b>Annex A (informative) Test report for CTS test</b> .....	<b>20</b>
<b>Annex B (informative) Test report for Y- or U-joint (TEKKEN) weld cracking test</b> .....	<b>21</b>
<b>Annex ZA (normative) Normative references to International publications with their relevant European publication</b> .....	<b>22</b>

## Foreword

This document (EN ISO 17642-2:2005) has been prepared by Technical Committee CEN/TC 121 "Welding", the secretariat of which is held by DIN, in collaboration with Technical Committee ISO/TC 44 "Welding and allied processes".

This European Standard shall be given the status of a national standard, either by publication of an identical text or by endorsement, at the latest by September 2005, and conflicting national standards shall be withdrawn at the latest by September 2005.

EN ISO 17642 consists of the following parts, under the general title *Destructive tests on welds in metallic materials - Cold cracking tests for weldments - Arc welding processes*:

- Part 1: General
- Part 2: Self-restraint tests
- Part 3: Externally loaded tests

According to the CEN/CENELEC Internal Regulations, the national standards organizations of the following countries are bound to implement this European Standard: Austria, Belgium, Cyprus, Czech Republic, Denmark, Estonia, Finland, France, Germany, Greece, Hungary, Iceland, Ireland, Italy, Latvia, Lithuania, Luxembourg, Malta, Netherlands, Norway, Poland, Portugal, Slovakia, Slovenia, Spain, Sweden, Switzerland and United Kingdom.

**(standards.iteh.ai)**

[SIST EN ISO 17642-2:2005](https://standards.iteh.ai/catalog/standards/sist/75a9c612-a721-4cc5-a43b-b4170a90b845/sist-en-iso-17642-2-2005)

<https://standards.iteh.ai/catalog/standards/sist/75a9c612-a721-4cc5-a43b-b4170a90b845/sist-en-iso-17642-2-2005>

## EN ISO 17642-2:2005 (E)

### 1 Scope

This standard specifies the sizes of the test pieces, the specimens and the procedures for carrying out self-restraint cold cracking tests by:

- CTS(Controlled Thermal Severity)-test
- Tekken (Y-groove) or Lehigh (U-groove) test

in order to obtain information about the cold cracking sensitivity during welding.

This standard applies primarily but not exclusively to C-Mn and low alloy steels.

### 2 Normative references

The following referenced documents are indispensable for the application of this document. For dated references, only the edition cited applies. For undated references, the latest edition of the referenced document (including any amendments) applies.

EN 1043-1:1995, *Destructive tests on welds in metallic materials — Hardness testing — Part 1: Hardness test on arc welded joints*

EN 1321, *Destructive tests on welds in metallic materials — Macroscopic and microscopic examination of welds*

EN ISO 3690, *Welding and allied processes - Determination of hydrogen content in ferritic arc weld metal (ISO 3690:2000)*

EN ISO 17642-1:2004, *Destructive tests on welds in metallic materials - Cold cracking tests for weldments - Arc welding processes - Part 1: General (ISO 17642-1:2004)*

### 3 Terms and definitions

For the purposes of this document, the terms and definitions given in EN ISO 17642-1:2004 apply.

## 4 Designation and symbols

The following designations and symbols given in Table 1 apply.

**Table 1 — Designation and symbols**

Symbol	Designation	Unit
	CTS-test	
$t$	material thickness	mm
$L_V$	leg length vertical	mm
$L_H$	leg length horizontal	mm
$L$	length of the test bead	mm
	Tekken or Lehigh test (Y and U-groove)	
$t$	material thickness	mm
$g$	root gap	mm
$W$	diameter of drilled hole and groove width	mm
$C_f$	crack ratio for surface cracks	%
$C_r$	crack ratio for root cracks	%
$C_s$	crack ratio for cracks in sections	%
$l_f$	length of surface crack	mm
$l_r$	length of root crack	mm
$H_C$	height root crack	mm
$H$	minimum thickness of test bead	mm
$L$	length of the test bead	mm

## 5 Principle

SIST EN ISO 17642-2:2005

<https://standards.iteh.ai/catalog/standards/sist/75a9c612-a721-4cc5-a43b-b4170a90b845/sist-en-iso-17642-2-2005>

### 5.1 General

The self-restraint cold cracking tests are designed to assess the cold cracking sensitivity of the parent materials and the arc welding consumables. The test consists of depositing a weld bead on a test sample made of two plates with pre-defined conditions and to examine transverse cut faces of the weld with a view to detect possible cracks either in the weld metal or in the heat affected zone.

This test procedure essentially applies to metal arc welding with covered electrodes and semi-automatic gas metal arc welding using solid and tubular wires. In general this method is not used for high current processes such as submerged-arc welding.

### 5.2 Qualitative evaluation

When using well determined welding conditions for welding a given material, a single evaluation test is performed. In the case of the CTS-test, the two test welds are examined.

### 5.3 Quantitative evaluation

When aiming at determining the cracking limit, a series of tests shall be performed. The no crack test shall be repeated, on the contrary, other tests shall be performed.

## EN ISO 17642-2:2005 (E)

## 6 Test

## 6.1 CTS-test

## 6.1.1 Dimensions of the test pieces

The dimensions of the test piece shall be in accordance with Figure 1.

Dimensions in millimetres

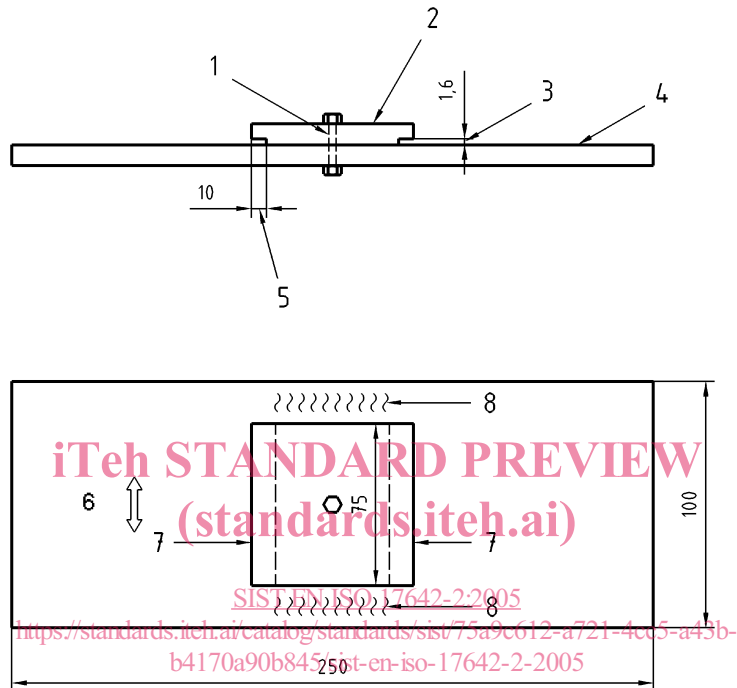

## Key

- 1 Clearance hole 13 mm diameter
- 2 Top plate
- 3 Root notch gap
- 4 Bottom plate
- 5 Root notch depth
- 6 Preferred principal rolling direction
- 7 Test welds
- 8 Anchor welds

Figure 1 — CTS test

## 6.1.2 Preparation of the test pieces

All test pieces shall be prepared from those parent materials which are actually to be welded with the welding consumables to be tested (see Figure 2).

Machine the test material for the pieces by sawing, milling or grinding. Ensure that surfaces to be welded are milled or ground finish. Take care to minimize heating and deformation in the material during machining.

Use the general arrangement of the test piece shown in Figure 1 and the tolerances and surface finish requirements given in Table 2.



**Table 2 — CTS test piece dimensions/conditions and tolerances**

Dimension/conditions	Values
Material thickness, $t$	6 mm min.
Top block	$(75 \pm 1)$ mm x $(75 \pm 1)$ mm x $t$
Bottom block	$(250 \pm 3)$ mm x $(100 \pm 3)$ mm x $t$
Root notch depth	$(10 \pm 0,5)$ mm
gap	$(1,6 \pm 0,10)$ mm
Torque on bolt	$(100 \pm 5)$ N·m
Surface finish on mating faces	$3,2 \mu\text{m } R_a$ max.
Surface finish on area to be welded	$6,3 \mu\text{m } R_a$ max.
Mating face gap	0,05 mm max.

Top and bottom blocks shall both have the same thickness. Top blocks shall be machined and bottom blocks may be machined or flame cut. Both blocks shall be of the same material.

In those exceptional circumstances where it is impossible to machine both blocks from the test material, the top block shall be from the material under test and the bottom block from a material of equivalent yield strength. It is important that the susceptibility of the bottom block to HAZ hydrogen cracking is less than that of the test material.

Where the principal rolling direction of the plate can be determined, arrange the rolling directions of the top and bottom plates to be the same (see Figure 1).

Ensure that the surfaces to be welded are ground smooth and free from scale, rust, oil, grease and other contaminants.

Use a bolt with a 12 mm diameter for assembling the blocks. Degrease the bolt, a suitable plain nut and any washers to be used prior to use. Do not use nuts and bolts treated by plating processes. Insert the bolt through the top and bottom blocks, add the nut and washers and tighten to the required torque (see Table 2). Check the torque value prior to all welding operations and adjust as necessary.

### 6.1.3 Anchor welds

Make the anchor welds (shown in Figure 1) with a welding consumable with a yield strength equal to or greater than the yield strength of the material under test, up to parent material yield strength of 895 N/mm<sup>2</sup>.

NOTE Where the yield strength of the parent material exceeds 895 N/mm<sup>2</sup>, the consumable selected can have a yield strength less than that of the parent material (but greater than 895 N/mm<sup>2</sup>) and /or austenitic stainless steel weld deposit can be used.

Start and finish the anchor fillet welds 10 mm ( $\pm 3$  mm) from the corners of the top plate and make them the following throat sizes:

up to 15 mm plate thickness:  $(6 \pm 1)$  mm;

plate thickness 15 mm and over:  $(13 \pm 1)$  mm.

**EN ISO 17642-2:2005 (E)**

Deposit the welds with a procedure to avoid hydrogen cracking, using preheat, interpass and post-heating control as necessary.

Dry all consumables used for anchor welds in accordance with the manufacturers' recommendations to give the lowest possible hydrogen levels.

Check the torque on the bolt and tighten the bolt where necessary. Leave the assembly for 12 h before test welding.

**6.1.4 Test welds****6.1.4.1 Preheating**

When the test piece is to be preheated, place the assembly in an oven and leave it for sufficient time to ensure even and thorough heating. Set the oven at a higher temperature than required for the test in order to allow for cooling of the assembly during transfer and set-up.

Prior to any welding, check the temperature of the test blocks using a calibrated surface pyrometer or thermocouple. Where the tests demand a specific preheat temperature, welding should not be commenced until the required temperature is achieved. Temperatures of the top and bottom blocks in the test area shall not differ by more than 5 °C.

**6.1.4.2 Deposition**

A jig should be used to position the assembly. The position of the electrode/wire with respect to the test block (see Figure 2) shall be such that the deposited test welds are symmetrically in the flat positions across the full width of the block in a single direction and in a single pass. Ensure that the test weld does not extend beyond the ends of the block.

SIST EN ISO 17642-2:2005  
<https://standards.iteh.ai/catalog/standards/sist/75a9c612-a721-4cc5-a43b-b4170a90b845/sist-en-iso-17642-2-2005>

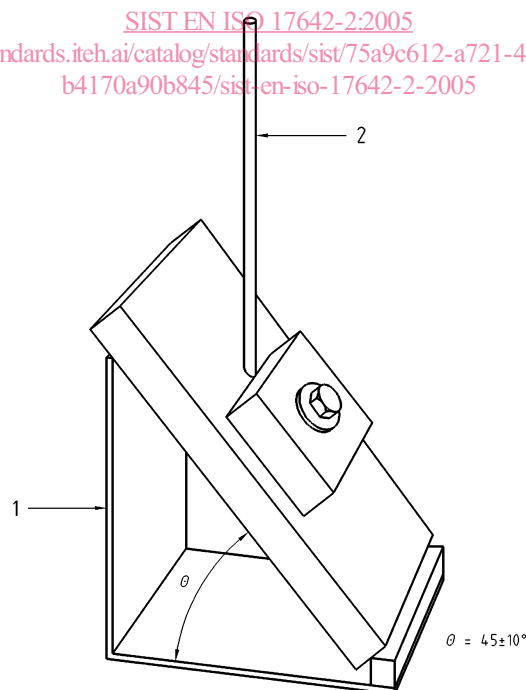
**Key**

- 1 Test jig
- 2 Welding consumable

**Figure 2 — Jig used to position test assembly**

Determine the weld length by measuring from the start of the weld to the centre of the weld crater as shown in Figure 3. Calculate the value of heat input (in kJ/mm).

NOTE Manual welding is difficult to control and monitor adequately. It is therefore recommended that mechanized deposition equipment is used.

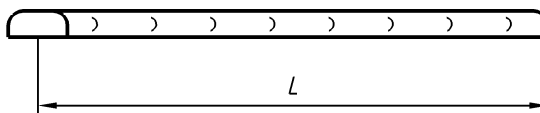

Figure 3 — Measurement of weld length,  $L$

#### 6.1.4.3 Post-heating

Where post-heating is to be carried out, transfer the assembly to an oven immediately following the completion of the first test welding. Monitor post-heating by using calibrated surface pyrometer or thermocouples.

#### 6.1.4.4 Cooling

Following deposition of the first test weld bead and after any post-heating treatment, transfer the test assembly to a cooling bath whereby the end of the assembly opposite the welded end is immersed in cold flowing water to a depth of  $(60 \pm 5)$  mm (see Figure 4).

Complete transfer to the bath within 60 s of the completion of welding (post-heating, where applied).

Ensure that the water temperature at the exit of the cooling bath does not exceed  $30\text{ }^{\circ}\text{C}$  during the test.

Keep the assembly in the bath until the temperature has fallen to ambient and then remove it.

<https://standards.iteh.ai/catalog/standards/sist/75a9c612-a721-4cc5-a43b-b4170a90b845/sist-en-iso-17642-2:2005>

Dimensions in millimetres

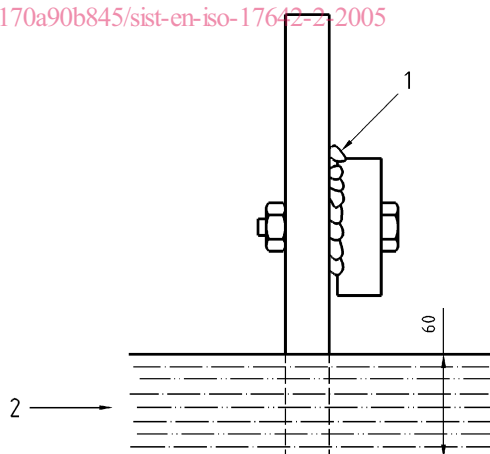

#### Key

- 1 Test weld
- 2 Water

Figure 4 — Cooling bath arrangement