International Standard



3463

INTERNATIONAL ORGANIZATION FOR STANDARDIZATION • МЕЖДУНАРОДНАЯ ОРГАНИЗАЦИЯ ПО СТАНДАРТИЗАЦИИ • ORGANISATION INTERNATIONALE DE NORMALISATION

Agricultural and forestry wheeled tractors — Protective structures — Dynamic test methods and acceptance conditions

Tracteurs à roues, agricoles et forestiers — Bâtis de protection — Méthodes d'essais dynamiques et conditions d'acceptation

First edition — 1981-12-01

UDC 631.372-78 : 620.1

Ref. No. ISO 3463-1981 (E)

Descriptors : agricultural machinery, tractors, overturning (vehicles), frames, safety devices, tests, dynamic tests, impact tests, crushing tests, dimensions, dimensional tolerances, test equipment, receiving.

Price based on 16 pages

Foreword

ISO (the International Organization for Standardization) is a worldwide federation of national standards institutes (ISO member bodies). The work of developing International Standards is carried out through ISO technical committees. Every member body interested in a subject for which a technical committee has been set up has the right to be represented on that committee. International organizations, governmental and non-governmental, in liaison with ISO, also take part in the work.

Draft International Standards adopted by the technical committees are circulated to the member bodies for approval before their acceptance as International Standards by the ISO Council.

International Standard ISO 3463 was developed by Technical Committee ISO/TC 23, *Tractors and machinery for agriculture and forestry*, and was circulated to the member bodies in November 1978.

It has been approved by the member bodies of the following countries :

Australia	Germany, F. R.	South Africa, Rep. of
Belgium	Italy	Spain
Brazil	Kenya	Sweden
Bulgaria	Korea, Dem. P. Rep. of	Switzerland
Chile	Korea, Rep. of	Turkey
Czechoslovakia	Mexico	United Kingdom
Denmark	Poland	USSR
France	Romania	Yugoslavia

The member bodies of the following countries expressed disapproval of the document on technical grounds :

Canada
Finland
New Zealand
USA

Agricultural and forestry wheeled tractors — Protective structures — Dynamic test methods and acceptance conditions

0 Introduction

The testing of the protective structures aims at minimizing the possibility of driver injury resulting from accidental overturning during normal operation of the tractor.

The strength of the protective structure is tested by simulating such loads as are imposed on the cab or frame when the tractor overturns either to the rear or to the side without free fall. The tests allow observations to be made on the strength of the structure and the attachment brackets on the tractor and also of the parts of the tractor that may be affected by the load imposed on the structure.

1 Scope

This International Standard specifies dynamic test methods and the acceptance conditions for protective structures (cab or frame) of agricultural and forestry wheeled tractors.

2 Field of application

This International Standard is applicable to tractors having at least two axles for pneumatic tyred wheels, with or without track attachments, and with a basic mass of 800 to 6 000 kg.

The minimum track width of rear wheels should generally be greater than 1 150 mm. It is recognized that there may be designs of tractors, for example, lawn mowers, narrow vineyard or low profile tractors used in low buildings with limited overhead clearance, orchards etc, stilt tractors and certain forestry machines such as forwarders, for which this International Standard is not appropriate.

3 References

ISO 612, *Road vehicles — Dimensions of motor vehicles and towed vehicles — Terms and definitions.*

ISO 2408, *Steel wire ropes for general purposes — Characteristics.*

ISO 3462, *Agricultural tractors and machinery — Seat reference point — Method of determination.*

4 Definitions

For the purpose of this International Standard the following definitions shall apply.

4.1 protective structure : A cab or frame for the protection of drivers of agricultural wheeled tractors by minimizing the possibility of driver injury resulting from accidental overturning during normal operations.

NOTE — The protective structure is characterized by providing space for the clearance zone either inside the envelope of the structure or within a space bounded by a series of straight lines from the outer edge of the structure to any part of the tractor that might come into contact with flat ground and is capable of supporting the tractor in that position if the tractor overturns.

4.2 basic tractor mass : The mass of the unladen tractor in working order with tanks and radiators full, protective structure with cladding, and any track equipment or additional front-wheel drive components required for normal use. The operator, removable ballast weights, special equipment and loads are not included.

4.3 impact test : The application of a dynamic load produced by a block acting as a pendulum.

4.4 crushing test : The application of a vertical load, through a beam placed laterally across the uppermost members of the protective structure.

4.5 longitudinal median plane (of a vehicle) : See ISO 612.

4.6 vertical reference plane (of a vehicle) : The vertical plane generally longitudinal to the tractor and passing through the seat reference point and the centre of the steering wheel.

NOTE — Normally this reference plane coincides with the longitudinal median plane of the tractor.

5 Symbols

m = Basic tractor mass, as defined in 4.2, in kilograms

m_t = Reference mass which shall be not less than the basic tractor mass, m , in kilograms

F = Static load force, in newtons

E = Energy input to be absorbed during test, in joules

H = The height of lift of the centre of gravity of the pendulum block, in millimetres

L = Reference wheelbase, which shall be not less than the maximum wheelbase, in millimetres

I = Reference moment of inertia about the rear axle, excluding the rear wheels which shall be not less than the maximum moment of inertia, in kilogram metre squared.

6 Apparatus

6.1 Clearance zone frame-work

Means for proving that the clearance zone has not been entered during the test. A measuring rig complying with figures 1, 2a) and 2b) can be used.

6.2 Impact tests

6.2.1 Arrangements for striking a blow against the protective structure shall be made by a pendulum block with a mass of 2 000 kg.

The mass of the pendulum block does not include the mass of the chains. The maximum chain mass shall be 100 kg.

The dimensions of the block, which shall be suspended in a bifilar manner from pivot points 6 m or more above ground level, shall be as shown in figure 3.

The centre of gravity of the pendulum block shall coincide with its geometric centre.

6.2.2 Means to ensure that the tractor is lashed to the ground. The tractor shall be lashed, by means of steel wire ropes incorporating tensioning devices, to ground rails which should preferably be spaced approximately 600 mm apart throughout the area immediately below the pivot points and extending for approximately 9 m along the axis of the pendulum block and approximately 1,8 m to either side. Details of the arrangements are given in figures 4, 5 and 6.

The wire rope shall be round, stranded with fibre core, construction 6 × 19 according to ISO 2408, using wire of tensile strength 1 700 N/mm².

The nominal diameter shall be as specified in table 1.

Table 1 — Nominal diameter of lashing ropes

Tractor mass kg	Rope diameter mm
Less than 5 000	13
5 000 or greater	16

6.2.3 Softwood beam, of cross-section 150 × 150 mm, for restraining the rear wheels when striking from the front and rear, and for clamping against the side of the front and rear wheels when striking from the side, as shown in figures 4, 5 and 6.

6.2.4 Wooden prop, for restraining the opposite rear wheel when striking from the side as shown in figure 6. Its length shall be 20 to 25 times its thickness and its width 2 to 3 times its thickness.

6.2.5 Device for measuring elastic deflection, such as that shown in figure 7, in a horizontal plane that coincides with the upper limiting surface of the clearance zone.

6.3 Crushing tests

6.3.1 Means for applying downwards force on the protective structure, such as that shown in figure 8, including a stiff beam with a width of 250 mm.

6.3.2 Equipment for measuring the total vertical force applied.

7 Preparation of tractor and protective structure

7.1 The protective structure shall be to the production specifications and shall be fitted to the appropriate tractor in accordance with the manufacturer's declared method of attachment.

7.2 A track width setting for the rear wheels shall be chosen such that, as far as possible, the protective structure is not supported by tyres during the test.

7.3 Cross-ply tires should preferably be used.

7.4 The gear lever shall be in neutral and the hand-brake lever in the off position.

7.5 All detachable windows, panels and removable non-structural fittings may be removed so that they do not contribute to the strength of the protective structure.

NOTE — In the cases where it is possible to fix doors and windows open, or remove them during work, they shall either be removed or fixed in the open position for the test, so that they do not add to the strength of the protective structure. It shall be noted whether, in this position, they would create a hazard for the driver in the event of over-turning.

7.6 Impact tests

7.6.1 General

The position of the block and its supporting chains shall be selected so that the point of the impact will be at the upper edge of the protective structure and in line with the arc of travel of the centre of gravity of the block.

The tractor shall be positioned and held securely in the area beneath the pivots so as to receive the blow in the appropriate manner.

The points of attachment of the lashing shall be approximately 2 m behind the rear axle and 1,5 m in front of the front axle.

The tyres of the tractor shall be inflated for different types of tractor (no water ballast being used), and the lashing tightened to give deflections appropriate to the type of tractor and tyre as shown in table 2.

Table 2 — Impact tests — Deflection

Type of tractor	Tyre pressure		Deflection mm
	kPa	(bar)	
Four-wheel drive with front and rear wheels of the same size :			
	Front	100	(1,0)
Rear	100	(1,0)	25
Four-wheel drive with front wheels smaller than rear wheels :			
	Front	150	(1,5)
Rear	100	(1,0)	25
Two-wheel drive :			
	Front	200	(2,0)
Rear	100	(1,0)	25

7.6.2 Front and rear impact tests

The lashings shall be one on each side of both axles giving a resultant force in the plane in which the centre of gravity of the block will swing.

After the lashings have been tightened for the front and rear blows, a beam (see 6.2.3) shall be clamped against the appropriate wheels on the side opposite the pendulum and driven tight against them (see figures 4 and 5).

7.6.3 Side impact test

The lashing shall be on the side of axles adjacent to the blow.

A beam (see 6.2.3) shall be clamped against the side of the front and rear wheels opposite the pendulum and driven hard against the tyres. After lashing, a beam (see 6.2.4) shall be placed as a prop against the rear wheel rim and secured to the floor so that it is held tight against the rim during the impact, as shown in figure 6. The length of the beam shall be chosen so that when in position against the rim it is at an angle of $30 \pm 3^\circ$ to the horizontal.

7.7 Crushing tests

When in position for the crushing test, the tractor shall be supported under the axles so that the load applied is not carried on the wheels.

8 Procedure

8.1 Sequence of tests

8.1.1 For tractors with less than 50 % of the unballasted weight on the front wheels, the following sequence shall be followed (the sub-clause numbers are those in which the tests are described) :

- impact from the rear, (see 8.2.1 and 8.2.2);
- crushing at the rear, (see 8.4.1);
- impact from the front, (see 8.2.1 and 8.2.3);
- impact from the side, (see 8.3);
- crushing at the front, (see 8.4.2).

8.1.2 For tractors with 50 % or more of the unballasted weight on the front wheels, the following sequence shall be followed (the sub-clause numbers are those in which the tests are described) :

- impact from the front, (see 8.2.1 and 8.2.3);
- impact from the side, (see 8.3);
- crushing at the rear, (see 8.4.1);
- crushing at the front, (see 8.4.2).

8.1.3 No repairs or straightening of any member shall be carried out between tests.

8.1.4 If a protruding member would present an inadequate area for the pendulum block, a steel plate of appropriate thickness and depth and about 300 mm in length shall be fastened to the member in such a manner that the strength of the protective structure is not affected.

8.1.5 The energy input to be absorbed by the protective structure during test shall be reported and is calculated by the formula :

$$E = 19,6 H (J)$$

8.2 Impact from the rear and front

8.2.1 Positioning of the tractor

For the impact tests to the rear and front, the tractor shall be positioned so that the supporting chains and the face of the pendulum block are at an angle of 20° to the vertical when striking the protective structure. If the angle of the protective structure member at the point of contact at maximum deflection

during impact will be greater than 20° to the vertical, the angle of the block shall be further adjusted by any convenient means so that the striking face and the protective structure member are parallel at the point of impact and maximum deflection, the supporting chains being at 20° to the vertical when the block strikes the protective structure.

NOTE — In the case of an angle greater than 20°, the adjustment of the striking face at the pendulum block has to be based on estimated maximum deformation.

8.2.2 Impact from the rear

The rear impact is not required on tractors having 50 % or more of the unballasted weight on the front wheels.

The rear blow shall be struck in a vertical plane parallel to the longitudinal medium plane on the corner opposite to that on which the side impact (see 8.3) is made and at two-thirds of the distance from the median plane of the tractor to the vertical plane touching the outside extremity of the top of the protective structure. However, if a curve in the back of the protective structure starts at less than two-thirds of the distance from the centre, the impact shall be at the beginning of that curve, i.e. at the point where this curve is tangential to a line at right angles to the median plane of the tractor.

The height of the lift of the pendulum block shall be calculated from either of the following formulae. The choice of the formula to be used is at the discretion of the manufacturer.

$$\text{Alternative 1 : } H \text{ (mm)} = 2,165 \times 10^{-8} m_t L^2$$

$$\text{Alternative 2 : } H \text{ (mm)} = 5,74 \times 10^{-2} I$$

8.2.3 Impact from the front

The general provisions for this test are similar to those for the impact from the rear. The blow shall be struck as close to the corner of the top of the protective structure as is practicable on the same side as that on which the side impact is made (see 8.3).

NOTE — "As close to the corner as practicable" means 80 mm maximum from a vertical plane parallel to the longitudinal medium plane of the tractor touching the outside extremity of the top of the protective structure. However, if a curve in the front of the protective structure starts at a longer distance than 80 mm inside this vertical plane, the impact shall be administered at the beginning of the curve, i.e. at the point where this curve is tangential to a line at right angles to the medium plane of the tractor.

The lift of the pendulum block shall be calculated from the following formulae :

$$- H = 25 + 0,07 m_t \text{ where } m_t = 800 \text{ to } 2\,000 \text{ kg}$$

$$- H = 125 + 0,02 m_t \text{ where } m_t = 2\,000 \text{ to } 6\,000 \text{ kg}$$

8.3 Impact from either side

8.3.1 Positioning of the tractor

For the side impact test the direction of the impact shall be horizontal.

The tractor shall be positioned so that the supporting chains and the striking face of the pendulum block are vertical when striking the protective structure. If the angle of the protective structure member at the point of contact is not vertical, the striking face of the pendulum block and the protective structure members shall be set parallel at the point of impact at maximum deflection by one additional support. The supporting chains shall remain vertical at the point of impact.

NOTE — In the case of non-vertical structure members, the adjustment of the striking face of the pendulum block has to be based on estimated maximum deformation.

8.3.2 Impact from the side

If it is certain that any particular member will take the initial impact when the tractor overturns sideways, the impact shall be struck against this member. Otherwise, the impact shall be struck against an uppermost side member and in the vertical plane perpendicular to the longitudinal medium plane (see clause 10) and 200 mm forward of the seat reference point, the seat being in its mid fore-and-aft position for seated operators. In case of an offset seat and/or non-symmetrical strength of the protective structure, the side blow shall be on the side more likely to lead to infringement of the zone of clearance.

The height of the lift of the pendulum block shall be calculated from the following formulae :

$$- H = 25 + 0,2 m_t \text{ where } m_t = 800 \text{ to } 2\,000 \text{ kg}$$

$$- H = 125 + 0,15 m_t \text{ where } m_t = 2\,000 \text{ to } 6\,000 \text{ kg}$$

8.4 Crushing tests

8.4.1 Crushing at the rear

The beam shall be positioned across the rear uppermost structural members and the resultant crushing forces shall be located in the vertical reference plane. The force F shall be applied, where $F = 20 m_t$ (N). This force shall be maintained for at least 5 s after the cessation of any visually detectable movement of the protective structure.

Where the rear part of the protective structure roof will not sustain the full crushing force, the force shall be applied until the roof is deflected to coincide with the plane joining the upper part of the protective structure with that part of the rear of the tractor capable of supporting the vehicle's mass when overturned. The force shall then be removed and the tractor or loading force repositioned so that the beam is over that point of the protective structure which would then support the front of the tractor when completely overturned and the full force applied.

8.4.2 Crushing at the front

The beam shall be positioned across the front uppermost structural members and the resultant crushing forces shall be located in the vertical reference plane. The force F shall be applied where $F = 20 m_t$ (N). This force shall be maintained for at least 5 s after the cessation of any visually detectable movement of the protective structure.

Where the front part of the roof of the protective structure will not sustain the full crushing force, the force shall be applied until the roof is deflected to coincide with the plane joining the upper part of the protective structure with that part of the front of the tractor capable of supporting the vehicle mass when overturned. The force shall then be removed and the tractor or loading force repositioned so that the beam is over that part of the protective structure which would then support the rear of the tractor when completely overturned and the full force applied (see figure 9).

9 Seat reference point

The seat reference point shall be determined, in accordance with ISO 3462, with the seat adjusted to its rearmost and uppermost position.

For a suspended seat, the suspension shall be set to the mid-point of the suspension travel, unless this is contradictory to clearly stated instructions by the manufacturer of the seat. Where special instructions for the seat setting exist, these shall be observed.

10 Clearance zone

The clearance zone is illustrated in figures 1, 2a) and 2b). Referring to the figures, the zone is defined in relation to the vertical reference plane (see 4.6). This reference plane shall be assumed to move horizontally with the seat and steering wheel during impacts but to remain perpendicular to the tractor or the floor of the protective structure.

The clearance zone is defined as follows when the tractor is standing on its wheels on horizontal surface and, where applicable, the steering wheel is adjusted to the mid-position for seated driving.

- a) a horizontal plane — $A_1 B_1 B_2 A_2$ — 900 mm above the seat reference point;
- b) an inclined plane — $G_1 G_2 I_2 I_1$ — perpendicular to the reference plane and including the rearmost point of the seat backrest and whose extension passes through a point 900 mm directly above the seat reference point;
- c) a cylindrical surface — $A_1 A_2 I_2 I_1$ — perpendicular to the reference plane, with a radius of 120 mm tangential to the planes defined in a) and b) above;
- d) a cylindrical surface — $B_1 C_1 C_2 B_2$ — perpendicular to the reference plane, having a radius of 900 mm extending forward for 400 mm and tangential to the plane defined in a) above at a point 150 mm forward of the seat reference point;
- e) an inclined plane — $C_1 D_1 D_2 C_2$ — perpendicular to the reference plane, joining the surface defined in d) above at its forward edge and passing 40 mm from the rim of the steering wheel;
- f) a vertical plane — $D_1 E_1 E_2 D_2$ — perpendicular to the reference plane 40 mm from the rim of the steering wheel;

g) a horizontal plane — $E_1 F_1 F_2 E_2$ — through the seat reference point;

h) a surface curved if necessary — $G_1 F_1 F_2 G_2$ — from the bottom limit of the plane defined in b) above to the horizontal plane, defined in g) above, following the general direction of and in contact with the rear surface of the seat backrest;

j) vertical planes — $J_1 E_1 F_1 G_1 H_1$ and $J_2 E_2 F_2 G_2 H_2$ — not less than 250 mm on either side of the reference plane or 500 mm according to the greatest of the two values;

The distance $E_1 E_2$ shall be equal to the diameter of the steering wheel plus 40 mm on each side of the rim of the steering wheel or 500 mm, whichever is greater;

k) parallel planes — $A_1 B_1 C_1 D_1 H_1 I_1$ and $A_2 B_2 C_2 D_2 H_2 I_2$ — inclined so that the upper edge of the plane on the side to which the side blow is struck is at least 100 mm from the reference plane.

11 Tolerances

Measurements during the tests shall be made to the following tolerances :

- a) dimensions of the protective structure and tractor, clearance zone and tyre deflection when lashed for impact tests : ± 3 mm;
- b) deflection : ± 3 mm;
- c) height of lift of pendulum block set for impact tests : ± 6 mm;
- d) measured tractor mass : ± 20 kg;
- e) force applied in crushing tests : ± 2 %;
- f) mass of pendulum block (chain mass excluded) : ± 20 kg;
- g) angle of pendulum block supporting chains at the point of impact : $\pm 2^\circ$;
- h) moment of inertia : ± 5 %.

12 Conditions for acceptance

12.1 For the protective structure to be accepted it shall fulfil the conditions in 12.1.1 to 12.1.6 during and after the test.

12.1.1 No part shall enter the clearance zone as defined in clause 10. No part may strike the seat during the tests. Furthermore, the clearance zone shall not be outside the protection of the protective structure as defined in 4.1. For this purpose it shall be considered to be outside the protection of the protective structure if any part of it would have come in contact with flat ground had the tractor overturned towards the direction from which the blow was struck. For estimating this, the tyres and track width setting shall be the smallest standard fitting specified by the manufacturer.

12.1.2 The protective structure and tractor shall be visually examined for cracks and tears after each test. The following conditions shall be complied with :

- a) there shall be no cracks in structural members, mounting components or tractor parts contributing to the strength of the protective structure, except as covered by c);
- b) there shall be no cracks in welds contributing to the strength of the protective structure or its mounting components;
- c) energy absorbing tears in sheet metal structures are acceptable, provided that they are judged by the test station not to have significantly reduced the resistance to deflection of the protective structure.

NOTES

1 Tears in sheet metal components caused by the edge of the pendulum block shall normally be ignored.

2 Spot- or track-welding used for attachment of cladding panels shall normally be excluded from condition b) above.

12.1.3 There shall be no protruding member or component which would be likely to cause serious injury during an overturning accident or which, through the deformation occurring, might trap the operator, for example by a leg or foot.

12.1.4 There shall be no other components presenting a serious hazard to the operator.

12.1.5 During the side impact test, the elastic deformation shall not exceed 250 mm in a horizontal plane that coincides with the upper limiting surface of the clearance zone.

12.1.6 If the protective structure is claimed to meet cold weather embrittlement properties, the manufacturer shall state the standard met and this shall be included in the report.

12.2 In the case of a protective structure which has fulfilled the condition required for acceptance and which is designed to be used on other models of tractors, the tests as specified in clause 8 need not be carried out on each model of tractor, provided that the protective structure and tractor comply with the conditions in 12.2.1 to 12.2.5.

In such cases, the test report shall contain a reference to the previous test report.

12.2.1 The basic tractor mass shall not exceed the reference mass by more than 5 %.

12.2.2 If the height of lift of the pendulum block for the impact from the rear was calculated by alternative formula 1, the maximum wheelbase shall not exceed the reference wheelbase. If the height of lift of the pendulum block from the impact from the rear was calculated by alternative formula 2, the maximum moment of inertia about the rear axle shall not exceed the reference moment of inertia.

12.2.3 The method of attachment and the tractor components to which the attachment is made shall be identical or of equivalent strength.

12.2.4 Any components such as mudguards and bonnet, which may provide support for the protective structure shall be identical or judged to give at least the same support.

12.2.5 The position and critical dimensions of the seat in the protective structure and the relative position of the protective structure of the tractor shall be such that the clearance zone would have remained within the protection of the deflected structure throughout all the tests.

13 Test report

The test report shall be in accordance with annexes A and B.

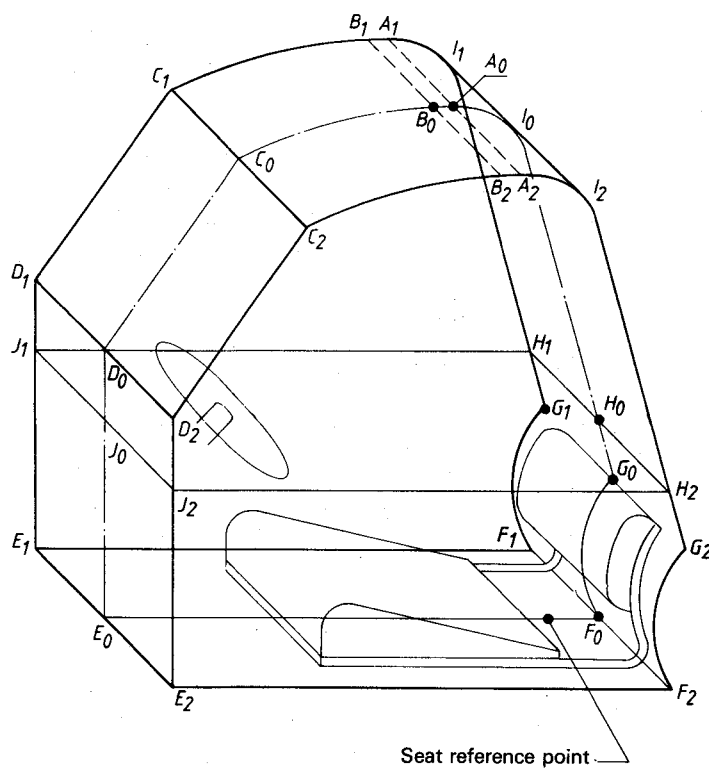

Dimensions	mm	Remarks
A_1A_0 B_1B_0	100	Minimum
A_1A_2 B_1B_2 C_1C_2	500	
D_1D_2 E_1E_2	500	
F_1F_2 G_1G_2 H_1H_2 I_1I_2 J_1J_2	500	
E_1E_0 E_2E_0	250	Minimum or equal to the radius of the steering wheel plus 40 mm, whichever is greater
J_0E_0 F_0G_0	300	
I_0G_0	—	
C_0D_0	—	
E_0F_0	—	

For other dimensions, see figures 2a) and 2b).

Figure 1 — Clearance zone

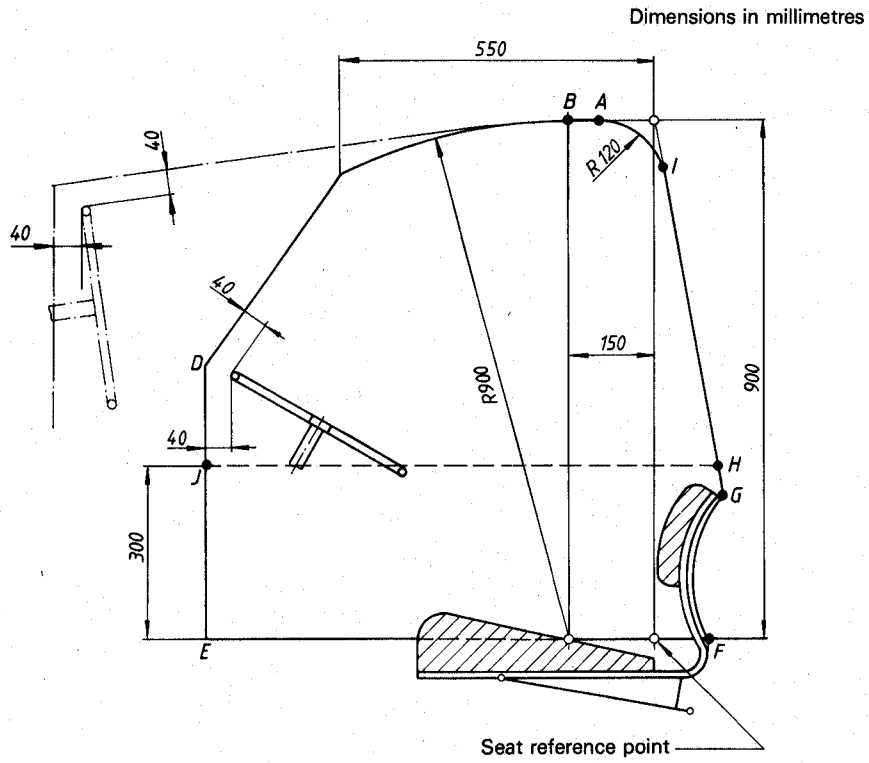

Figure 2a) – Clearance zone from the side

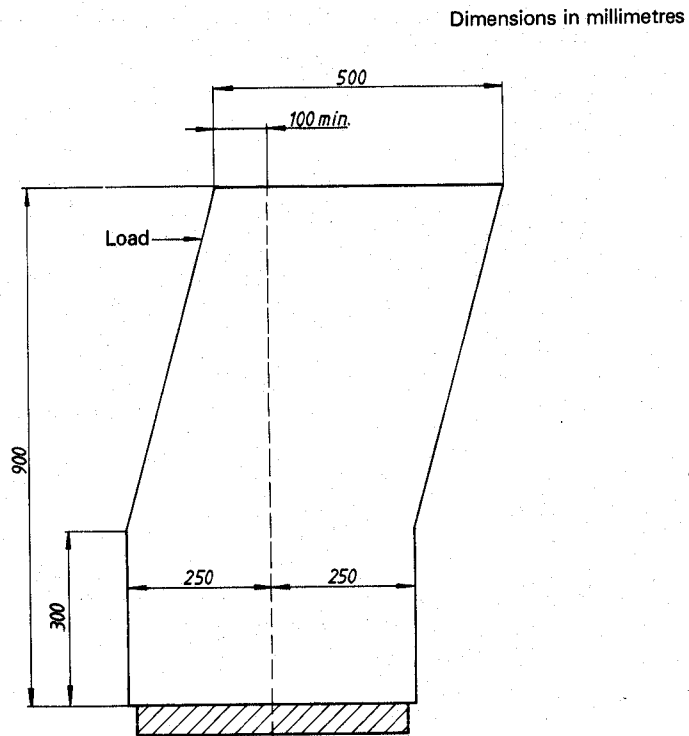

Figure 2b) – Clearance zone from the front/rear 150 mm in front of the seat reference point

Dimensions in millimetres

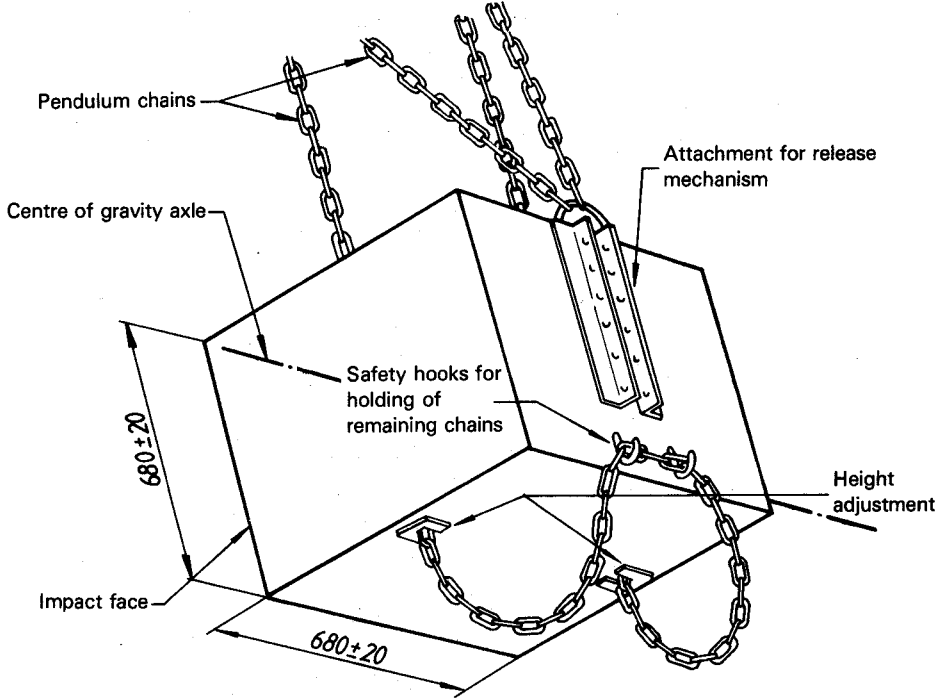

Figure 3 — Illustration of pendulum block

Dimensions in millimetres

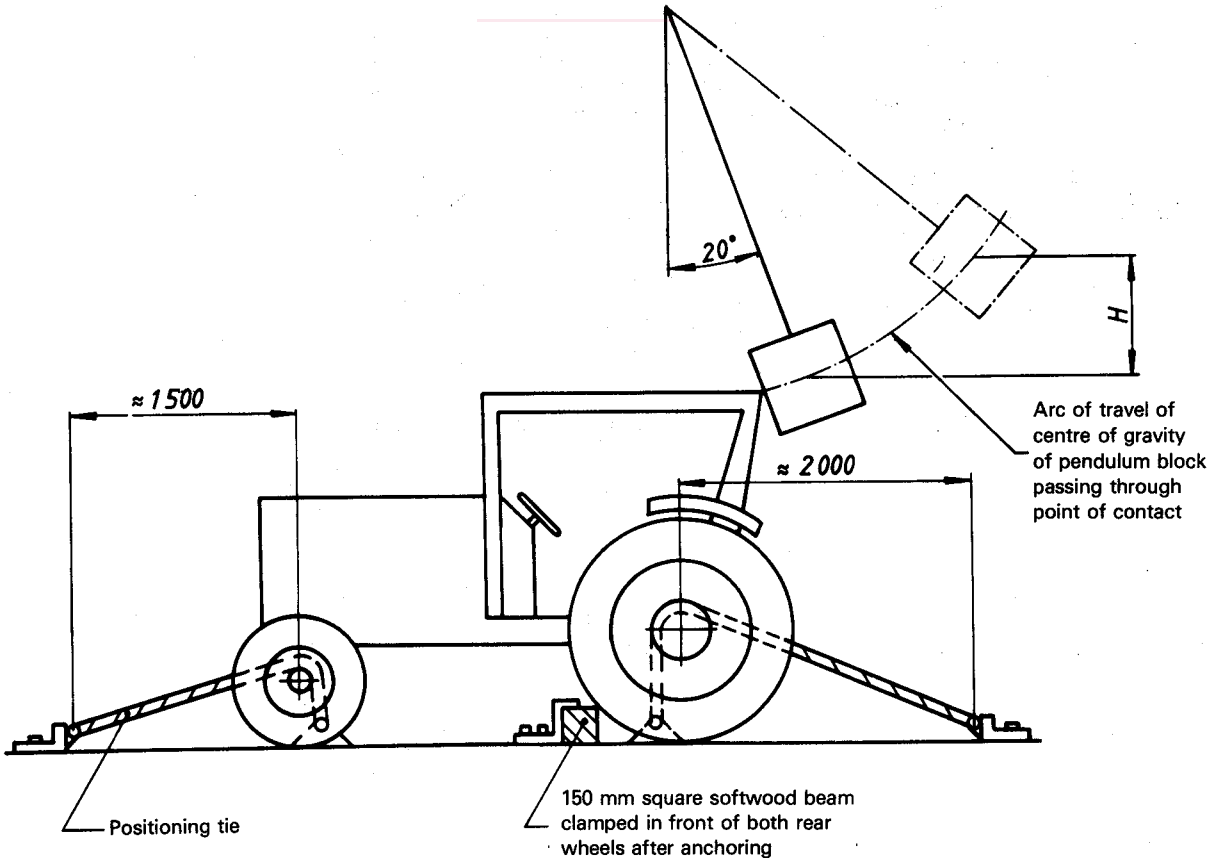

Figure 4 — Example of a method for lashing — Impact from rear