



Designation: E90-02 Designation: E 90 - 04

Standard Test Method for Laboratory Measurement of Airborne Sound Transmission Loss of Building Partitions and Elements¹

This standard is issued under the fixed designation E 90; the number immediately following the designation indicates the year of original adoption or, in the case of revision, the year of last revision. A number in parentheses indicates the year of last reapproval. A superscript epsilon (ϵ) indicates an editorial change since the last revision or reapproval.

This standard has been approved for use by agencies of the Department of Defense.

INTRODUCTION

This test method is part of a set for evaluating the sound-insulating properties of building elements. It is designed to measure the transmission of sound through a partition or partition element in a laboratory. Others in the set cover the measurement of sound isolation in buildings (Test Method E 336), the laboratory measurement of impact sound transmission through floors (Test Method E 492), the measurement of impact sound transmission in buildings (Test Method E 1007), the measurement of sound transmission through building facades and facade elements (Guide E 966), the measurement of sound transmission through a common plenum between two rooms (Test Method E 1414), a quick method for the determination of airborne sound isolation in multiunit buildings (Practice E 597), and the measurement of sound transmission through door panels and systems (Test Method E 1408).

1. Scope

1.1 This test method covers the laboratory measurement of airborne sound transmission loss of building partitions such as walls of all kinds, operable partitions, floor-ceiling assemblies, doors, windows, roofs, panels, and other space-dividing elements.

1.2 *Laboratory Accreditation*—A procedure for accrediting a laboratory for performing this test method is given in Annex A3.

1.3 *This standard does not purport to address all of the safety concerns, if any, associated with its use. It is the responsibility of the user of this standard to establish appropriate safety and health practices and determine the applicability of regulatory limitations prior to use.*

2. Referenced Documents

2.1 *ASTM Standards*:²

- C634 634 [Terminology Relating to Environmental Acoustics](#)
- E 336 [Test Method for Measurement of Airborne Sound Insulation in Buildings](#)
- E 413 [Classification for Rating Sound Insulation](#)
- E 492 [Test Method for Laboratory Measurement of Impact Sound Transmission Through Floor-Ceiling Assemblies Using the Tapping Method](#)
- E 597 [Practice for Determining a Single-Number Rating of Airborne Sound Isolation for Use in Multiunit Building Specifications](#)
- E 966 [Guide for Field Measurement of Airborne Sound Insulation of Building Facades and Facade Elements](#)
- E 1007 [Test Method for Field Measurement of Tapping Machine Impact Sound Transmission through Floor-Ceiling Assemblies and Associated Support Structures](#)
- E 1289 [Specification for Reference Specimen for Sound Transmission Loss](#)
- E 1332 [Classification for Determination of Outdoor-Indoor Transmission Class](#)
- E 1375 [Test Method for Measuring the Interzone Attenuation of Furniture Panels Used as Acoustical Barriers](#)
- E 1408 [Test Method for Laboratory Measurement of the Sound Transmission Loss of Door Panels and Door Systems](#)

¹ This test method is under the jurisdiction of ASTM Committee E33 on Building and Environmental Acoustics and is the direct responsibility of Subcommittee E33.03 on Sound Transmission.

Current edition approved May 10, 2002. Published August 2002. Originally published as E90-55. Last previous edition E90-99.

Current edition approved April 1, 2004. Published May 2004. Originally approved in 1955. Last previous edition approved 2002 E 90 - 02.

² *Annual Book of ASTM Standards*, Vol 04.06.

For referenced ASTM standards, visit the ASTM website, www.astm.org, or contact ASTM Customer Service at service@astm.org. For *Annual Book of ASTM Standards* volume information, refer to the standard's Document Summary page on the ASTM website.

~~E 1414 Test Method for Airborne Sound Attenuation Between Rooms Sharing a Common Ceiling Plenum²~~ Test Method for Airborne Sound Attenuation Between Rooms Sharing a Common Ceiling Plenum
~~E 2235 Test Method for Determination of Decay Rates for Use in Sound Insulation Test Methods~~

2.2 *ANSI Standards:*

- S1.4 Specification for Sound-Level Meters³
- S1.6 Standard Preferred Frequencies, Frequency Levels, and Band Numbers for Acoustical Measurements³
- S1.10 Pressure Calibration of Laboratory Standard Pressure Microphones³
- S1.11 Specification for Octave-Band and Fractional-Octave-Band Analog and Digital Filters³
- S12.31 Precision Methods for the Determination of Sound Power Levels of Broad-Band Noise Sources in Reverberation Rooms³

2.3 *ISO Standards:*

- ISO 717 Rating of Sound Insulation for Dwellings³
- ISO 3741 Acoustics—Determination of Sound Power Level of Noise Sources—Precision Methods for Broad-Band Sources in Reverberation Rooms³

3. Terminology

~~3.1 Definitions of the acoustical terms used in this test method are given in Terminology C634. A few definitions of special relevance are repeated here for convenience only.~~

- ~~3.1.1 *diffuse sound field*—the sound in a region where the sound intensity is the same in all directions and at every point.~~
- ~~3.1.2 *direct sound field*—the sound that arrives directly from a source without reflection.~~
- ~~3.1.3 *flanking transmission*—transmission of sound from the source to a receiving location by a path other than that under consideration—in this case other than through the test partition.~~
- ~~3.1.4 *reverberation room*—a room so designed that the reverberant sound field closely approximates a diffuse sound field, both in the steady state when the sound source is on, and during decay after the source of sound has stopped.~~
- ~~3.1.5 *reverberant sound field*—the sound in an enclosed or partially enclosed space that has been reflected repeatedly or continuously from the boundaries.~~
- ~~3.1.6 *sound transmission coefficient, τ (dimensionless)*—of a partition, in a specified frequency band, the fraction of the airborne sound power incident on the partition that is transmitted by the partition and radiated on the other side. (Note that, unless qualified, this term denotes the sound transmission coefficient obtained when the specimen is exposed to a diffuse sound field as approximated, for example, in reverberation rooms meeting the requirements of this test method.)~~
- ~~3.1.7 *sound transmission loss, TL* —of a partition, in a specified frequency band, ten times the common logarithm of the reciprocal of the sound transmission coefficient. The quantity so obtained is expressed in decibels.~~
- ~~3.1.7.1 For the purposes of this test method, transmission loss is operationally defined as the difference in decibels between the average sound pressure levels in the reverberant source and receiving rooms, plus ten times the common logarithm of the ratio of the area of the common partition to the sound absorption in the receiving room (see Eq 12).~~

3.1 The following terms used in this test method have specific meanings that are defined in Terminology C 634.

- acoustical barrier
- airborne sound
- average sound pressure level
- background noise
- damp
- decay rate
- decibel
- diffraction
- diffuse sound field
- direct sound field
- flanking transmission
- level
- octave band
- pink noise
- receiving room
- reverberant sound field
- reverberation room
- sabin
- sound absorption
- sound attenuation
- sound energy
- sound insulation
- sound isolation
- sound level
- sound power
- sound pressure

³ Available from the American National Standards Institute, 11 W. 42nd St., 13th Floor, New York, NY 10036.

sound pressure level
 sound transmission level
 sound transmission class
 sound transmission coefficient
 sound transmission loss
 source room
 unit

3.1.1 For the purposes of this test method, transmission loss is operationally defined as the difference in decibels between the average sound pressure levels in the reverberant source and receiving rooms, plus ten times the common logarithm of the ratio of the area of the common partition to the sound absorption in the receiving room (see Eq 11).

NOTE 1—Sound transmission coefficient and sound transmission loss are related by either of the two equations:

$$TL = 10 \log(1/\tau) \tag{1}$$

$$\tau = 10^{-TL/10} \tag{2}$$

3.2 *noise reduction, NR*—in sound transmission measurements, in a specified frequency band, the difference between the average sound pressure levels measured in two enclosed spaces or rooms due to one or more sound sources in one of them.

3.3 Definitions of Terms Specific to This Standard:

3.3.1

3.2.1 *sound absorption, A, [L²]*—of a room, in a specified frequency band, the hypothetical area of a totally absorbing surface without diffraction effects which, if it were the only absorbing element in the room, would give the same sound decay rate as the room under consideration. Note 2—Sound absorption is operationally defined by the Sabine decay rate equation (see Eq 9).

4. Summary of Test Method

4.1 Two adjacent reverberation rooms are arranged with an opening between them in which the test partition is installed. Care is taken that the only significant sound transmission path between rooms is by way of the test partition. An approximately diffuse sound field is produced in one room, the source room. Sound incident on the test partition causes it to vibrate and create a sound field in the second room, the receiving room. The space- and time-averaged sound pressure levels in the two rooms are determined (see Fig. 1). In addition, with the test specimen in place, the sound absorption in the receiving room is determined. The sound pressure levels in the two rooms, the sound absorption in the receiving room and the area of the specimen are used to calculate transmission loss as shown in Section 12. Because transmission loss is a function of frequency, measurements are made in a series of frequency bands.

4.2 Additional procedures that may be followed when testing doors are given in Test Method E 1408.

5. Significance and Use

5.1 Sound transmission loss as defined in Terminology C 6343-1.7, refers to the response of specimens exposed to a diffuse

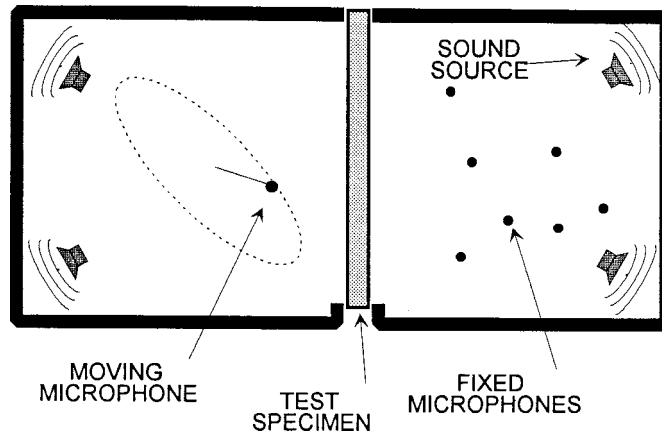

FIG. 1 Illustration showing conceptual arrangement of a wall sound transmission loss suite. This figure is not meant to be a design guide but is for illustrative purposes only. As an example, the room on the right has fixed microphones to measure average sound pressure level; the room on the left has a continuously moving microphone to measure average sound pressure level. Usually both rooms will have the same microphone system. The sound sources (loudspeakers) in the rooms generate the incident sound fields for the measurement of level differences or of sound decay rates. As shown, either room could serve as source or receiving room.

incident sound field, and this is the test condition approached by this laboratory test method. The test results are therefore most directly relevant to the performance of similar specimens exposed to similar sound fields. They provide, however, a useful general measure of performance for the variety of sound fields to which a partition or element may typically be exposed.

5.2 This test method is not intended for field tests. Field tests should be performed according to Test Method E 336.

6. Test Rooms

6.1 *Room Size and Shape*—To produce an acceptable approximation to the assumed diffuse sound fields, especially in the lowest test frequency band, the sound fields in the rooms must satisfy the requirements in Annex A2. They must also satisfy any of the following requirements that are mandatory.

6.1.1 *Minimum Volume*—The volume of the source and receiving rooms must each be 50 m³ (1765 ft³) or more.

6.2 *Room Absorption*—The sound absorption in each of the rooms should be made as low as possible to achieve the best possible simulation of the ideal diffuse field condition and to keep the region dominated by the direct field (of the source or of the test specimen) as small as possible (see 8.5). At each frequency, the sound absorption for each room (as furnished with diffusers) should be no greater than:

$$A = V^{2/3}/3 \quad (3)$$

where:

V = room volume, and

A = sound absorption of the room.

When V is expressed in cubic metres, A is in square metres. When V is expressed in cubic feet, A is in sabin (square feet). At low frequencies somewhat higher room absorption may be desirable to accommodate other test requirements (for example, ANSI S12.31, ISO 3741). Sound absorption in the room is usually increased at frequencies below $f = k_2/V^{1/3}$ (k_2 is an empirical constant equal to 2000 m/s when V is in cubic metres, and equal to 6562 ft/s when V is in cubic feet). In any case, the sound absorption should be no greater than three times the value given by Eq 3. For frequencies above 2000 Hz, atmospheric absorption may make it impossible to avoid a slightly higher value than that given in Eq 3.

6.2.1 Unless otherwise specified, the average temperatures in each room during all acoustical measurements shall be in the range $22 \pm 5^\circ\text{C}$.

6.2.2 When testing specimens that are windows or window systems, the average temperature of the specimen and in each room during all acoustical measurements shall be in the range $22 \pm 2^\circ\text{C}$.

NOTE 3—~~The 2—~~The sound damping properties of viscoelastic materials used to mount glass often depends on temperature. This requirement minimizes any effects this has on measured sound transmission loss.

6.2.3 During the ~~noise reduction~~ sound pressure level and sound absorption measurements, variations in temperature and humidity in the receiving room shall not exceed 3°C and 3% relative humidity respectively. Temperature and humidity shall be measured and recorded at the beginning and end of each test to ensure compliance.

6.3 *Methods to Reduce the Variability of the Sound Fields*—Meeting the requirements of 6.1 and 6.2 can be difficult in the lower test bands where results are likely to depend critically on arbitrary features of the test geometry such as positioning of the sound sources and individual microphones. Spatial variations in sound pressure level and decay rate may be reduced by one or both of the following types of diffusing panels. The recommendations that follow are only included as guidelines. Satisfaction of the requirements of Annex A2 for confidence intervals is the primary criterion, not the size or number of diffusing panels.

6.3.1 *Stationary Diffusing Panels*—It is recommended that each test room be fitted with a set of about 3 to 6 diffusing panels, suspended in random orientations throughout the room space. The appropriate number, distribution, and orientation of panels should be determined experimentally by checking to see if spatial variances of sound pressure level or decay rate are reduced. Lateral panel dimensions should be about $\frac{1}{2}$ to 1 wave-length of the sound at the lowest test band, for example, about 1.2 to 2.5 m. The recommended minimum mass per unit area of the panels is 5 kg/m² (1 lb/ft²) for operation down to 100 Hz. (Panels of plywood or particleboard measuring 1.2 × 2.4 m are often used.) To be effective at lower frequencies, the size and mass of diffusing panels should be increased in proportion to the wavelength. It is likely to be impractical to use very large diffusing panels at very low frequencies; they might make the room behave like a number of coupled spaces rather than a single room, and it might be difficult to position microphones.

6.3.2 *Rotating or Moving Diffusers*—One or more rotating or moving panels set at oblique angles to the room surfaces may be installed in either or both rooms. The recommendations for weight and size of the panels given in 6.3.1 for fixed diffusing panels apply also to rotating or moving diffusers. The panels should be large enough that during motion they produce a significant variation in the sound field, yet small enough that they do not effectively partition the room at any point in their movement.

NOTE 4—~~Moving 3—~~Moving diffusers can generate mechanical noise or wind and wind noise in microphones. This increased background noise may make measurements difficult in some cases.

6.4 *Flanking Transmission*—The test rooms shall be constructed and arranged to minimize the possibility of transmission by paths other than that through the test partition. Sound pressure levels produced by such flanking transmission should be at least 10 dB lower than the sound radiated into the receiving room by the test partition. Supporting one or both rooms on vibration isolators (resilient materials or springs) is a common method of reducing flanking transmission. Structural discontinuities are

recommended between the source-room and the test specimen and between the receiving room and the test specimen to minimize flanking transmission between them.

NOTE 5—~~If 4—~~If the specimen is rigidly connected to the source-room structure, there is some risk that, in addition to the incident airborne sound, sound power may enter the specimen at the edges because of vibration of the source-room structure. Similarly, if the specimen is rigidly connected to the receiving room structure, sound power may flow from the specimen to the walls of the receiving room and be radiated from them.

6.4.1 The limit on specimen transmission loss measurement due to flanking transmission must be investigated as follows:

6.4.1.1 In the test opening, build a partition expected to have high transmission loss.

6.4.1.2 Measure the transmission losses following this test method.

6.4.1.3 Increase the expected transmission losses by making a substantial improvement to the test partition, for example, by adding a heavy shielding structure in front of the test partition.

6.4.1.4 Measure the transmission loss again.

6.4.1.5 Repeat steps 6.4.1.3 and 6.4.1.4 until significant additions to the test partition no longer significantly increase the measured transmission loss. The sound transmission loss measured can then be ascribed to flanking paths. The transmission loss values obtained represent the limit that can be measured by the facility. Unless steps are taken to eliminate them, these paths always exist and will reduce the measured transmission loss for partitions whose inherent transmission loss values are within 10 dB of the flanking limit. The sound power transmission along a particular suspected flanking path may be decreased to determine if the measured transmission loss increases. This may be done by temporarily adding shielding structures in front of the surfaces that are suspected of radiating unwanted sound.

6.4.2 A potential flanking path is through the perimeter of the partition or the mounting frame **(1)**.⁴ It is therefore important that the partition mounting arrangement used in determining the transmission loss limit be the same as is used for routine testing.

6.4.3 An extraneous signal similar in effect to flanking transmission may be produced by electrical “cross-talk” between the electrical system driving the sound source or other devices and the receiving microphone systems. This possibility should be checked, whenever systems are changed, by measuring the residual signals when the loudspeaker is replaced by an equivalent electrical load or by replacing the microphone cartridge with a dummy load.

6.4.4 Laboratories must keep records of data collected to establish the flanking limit of their facilities.

6.4.5 When the transmission loss measured for a test specimen in a particular frequency band is within 10 dB of the flanking limit established for the laboratory, the transmission loss value must be clearly identified in the test report as being potentially limited by the laboratory. The true value may be higher than that measured.

7. Test Specimens

7.1 *Size and Mounting*—Any test specimen that is to typify a wall or floor shall be large enough to include all the essential constructional elements in their normal size, and in a proportion typical of actual use. The minimum dimension (excluding thickness) shall be 2.4 m, except that specimens of doors, office screens, and other smaller building elements shall be their customary size. Preformed panel structures should include at least two complete modules (panels plus edge mounting elements), although single panels can be tested. In all cases the test specimen shall be installed in a manner similar to actual construction, with a careful simulation of normal constraint and sealing conditions at the perimeter and at joints within the field of the specimen. Detailed procedures for particular types of building separation elements are recommended in Annex A1.

7.2 *Aging of Specimens*—Test specimens that incorporate materials for which there is a curing process (for example adhesives, plasters, concrete, mortar, damping compound) shall age for a sufficient interval before testing. Manufacturers may supply information about curing times for their products. Aging periods for certain common materials are given in Annex A1.

7.2.1 For materials whose aging characteristics are not known, tests shall be repeated over a reasonable time on at least one specimen to determine an appropriate aging period. A suggested procedure is to test at intervals in the series 1, 2, 4, 7, 14, and 28 days from the date of construction, until no significant change is observed between successive tests. The minimum aging period should be the interval beyond which no significant change is observed.

7.2.1.1 To decide whether a change is significant, laboratory operators must determine the repeatability of their test procedures. This is done by repeating the complete test procedure several times without disturbing the specimen or other apparatus and with as little time as possible between repeat measurements. From the set of transmission loss measurements, calculate the standard deviation of transmission loss at each frequency. Standard statistical techniques **(2)** may then be used to decide if a test differs significantly from a previous test. In many cases, a visual comparison of two results will be enough to verify that there is no significant difference between two results.

7.3 *Testing of Specimens Smaller Than Test Opening* —When the area of the test specimen is smaller than that of the normal test opening, the area of the test opening must be reduced using additional construction. This additional construction, or filler wall, should be designed to transmit as little sound as possible. Nevertheless, a portion of the sound may be transmitted by way of the filler wall (see Fig. 2). Sound transmission through the composite wall can be represented by:

$$\tau_c S_c = \tau_s S_s + \tau_f S_f \quad (4)$$

⁴ The boldface numbers in parentheses refer to the list of references at the end of this test method.

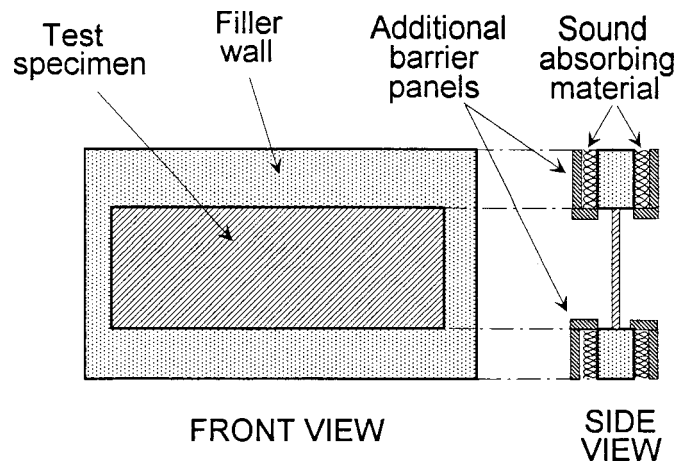

FIG. 2 Illustration showing filler wall and test specimen that is smaller than the test opening. This figure is not meant to be a design guide but is for illustrative purposes only. The side view shows the application of additional panels as discussed in 7.3.2.

or

$$\tau_s = (\tau_c S_c - \tau_f S_f) / S_s \quad (5)$$

where:

- S_c = area of composite construction ($S_c = S_s + S_f$),
- S_s = area of test specimen,
- S_f = area of filler element,
- τ_c = transmission coefficient of composite construction,
- τ_s = transmission coefficient of test specimen, and
- τ_f = transmission coefficient of filler element.

NOTE 6—The 5—The above expressions assume that the two parts of the composite construction react to the sound field independently of each other.

Two general procedures may be used to deal with this situation:

7.3.1 *Build and Measure a Complete Filler Wall*—This is the preferred method and is usually most convenient when the specimen area is smaller than the area of the filler wall. Based on experience and knowledge of the test specimen construction, build a filler wall that is expected to transmit a negligible amount of sound relative to that through the specimen. The filler wall should be built with support structures for the test specimen already in place. The opening for the specimen shall be closed and finished with the same construction as the rest of the filler wall, except as noted in 7.3.2.

7.3.1.1 Following the procedures in this test method, measure the sound transmission losses for this complete filler wall. The transmission coefficients, τ_f , for the filler wall can be calculated from the corresponding transmission losses using Eq 2.

7.3.1.2 Remove the part of the filler wall surfaces covering the opening for the specimen and install the specimen. Make no other significant changes to the filler wall structure.

7.3.1.3 Following the procedures in this test method, measure the sound transmission losses for this composite wall. The transmission coefficients, τ_c , can be calculated from the corresponding transmission losses using Eq 2. The area used in calculation is the combined area of the specimen and the filler wall, S_c .

7.3.1.4 At each test frequency calculate the difference: $10 \log(\tau_c S_c) - 10 \log(\tau_f S_f)$.

7.3.1.5 If the difference is more than 15 dB, calculate τ_s from Eq 5 ignoring the term $\tau_f S_f$.

7.3.1.6 If the difference is between 6 and 15 dB, calculate τ_s using Eq 5. This corrects for transmission through the filler wall. Note in the test report where such corrections have been made.

7.3.1.7 If the difference is less than 6 dB, reliable corrections cannot be made. Calculate τ_s from Eq 5 ignoring the term $\tau_f S_f$. Multiply the value obtained by 0.75 and then use Eq 1 to calculate a lower limit for the transmission loss of the test specimen. (This is equivalent to limiting the difference to 6 dB.) Any values of transmission loss that are limited in this way must be clearly marked as such in the test report.

7.3.2 *Use Additional Structures to Reduce Transmission*—Some test specimens fill a large fraction of the test opening leaving only a small area for a filler wall. In such cases, it is not always convenient to construct and test a complete filler wall and the transmission coefficient of the filler wall is not known. To demonstrate that transmission through the filler wall is negligible, proceed as follows:

7.3.2.1 Measure the sound transmission loss for the composite assembly.

7.3.2.2 Cover each face of the filler wall with sound absorbing material at least 50 mm (2 in.) thick. Cover the sound absorbing material with barrier panels weighing at least 8 kg/m^2 (1.6 lb/ft^2) that are not rigidly attached to the filler wall (see Fig. 2). Normal