



SLOVENSKI STANDARD
SIST EN 1804-1:2002+A1:2010
01-marec-2010

**Stroji za podzemne rudnike - Varnostne zahteve za hidravlično podporje - 1. del:
Deli podporja in splošne zahteve**

Machines for underground mines - Safety requirements for hydraulic powered roof supports - Part 1: Support units and general requirements

Maschinen für den Bergbau unter Tage - Sicherheitsanforderungen für hydraulischen Schreitausbau - Teil 1: Ausbaugestelle und allgemeine Anforderungen

Machines pour mines souterraines - Exigences de sécurité relatives aux soutènements marchants applicables aux piles - Partie 1: Unités de soutènement et exigences générales

<https://standards.iteh.ai/catalog/standards/sist/e6aff071-2bf8-449f-8e4a-474d09c7d86d/sist-en-1804-1-2002a1-2010>

Ta slovenski standard je istoveten z: EN 1804-1:2001+A1:2010

ICS:

73.100.10 Oprema za gradnjo predorov Tunnelling and tubbing
in podzemnih železnic equipment

SIST EN 1804-1:2002+A1:2010 en,fr,de

iTeh STANDARD PREVIEW
(standards.iteh.ai)

SIST EN 1804-1:2002+A1:2010

<https://standards.iteh.ai/catalog/standards/sist/e6aff071-2bf8-449f-8e4a-474d09c7d86d/sist-en-1804-1-2002a1-2010>

EUROPEAN STANDARD
NORME EUROPÉENNE
EUROPÄISCHE NORM

EN 1804-1:2001+A1

January 2010

ICS 73.100.10

Supersedes EN 1804-1:2001

English Version

Machines for underground mines - Safety requirements for hydraulic powered roof supports - Part 1: Support units and general requirements

Machines pour mines souterraines - Exigences de sécurité relatives aux soutènements marchants applicables aux piles - Partie 1: Unités de soutènement et exigences générales

Maschinen für den Bergbau unter Tage - Sicherheitsanforderungen für hydraulischen Schreitausbau - Teil 1: Ausbaugestelle und allgemeine Anforderungen

This European Standard was approved by CEN on 21 September 2001 and includes Amendment 1 approved by CEN on 21 December 2009.

CEN members are bound to comply with the CEN/CENELEC Internal Regulations which stipulate the conditions for giving this European Standard the status of a national standard without any alteration. Up-to-date lists and bibliographical references concerning such national standards may be obtained on application to the CEN Management Centre or to any CEN member.

This European Standard exists in three official versions (English, French, German). A version in any other language made by translation under the responsibility of a CEN member into its own language and notified to the CEN Management Centre has the same status as the official versions.

CEN members are the national standards bodies of Austria, Belgium, Bulgaria, Croatia, Cyprus, Czech Republic, Denmark, Estonia, Finland, France, Germany, Greece, Hungary, Iceland, Ireland, Italy, Latvia, Lithuania, Luxembourg, Malta, Netherlands, Norway, Poland, Portugal, Romania, Slovakia, Slovenia, Spain, Sweden, Switzerland and United Kingdom.



EUROPEAN COMMITTEE FOR STANDARDIZATION
COMITÉ EUROPÉEN DE NORMALISATION
EUROPÄISCHES KOMITEE FÜR NORMUNG

Management Centre: Avenue Marnix 17, B-1000 Brussels

Contents

Page

Foreword.....	3
Introduction	4
1 Scope	4
2 Normative references	5
3 Terms and definitions	6
4 List of hazards	7
5 Safety requirements	8
6 Verification of the safety requirements	13
7 User information	14
Annex A (normative) Tests for verification of the safety requirements and calculation	19
Annex ZA (informative) $\overline{A1}$ Relationship between this European Standard and the Essential Requirements of EU Directive 2006/42/EC $\overline{A1}$	37
Bibliography	38

iTeh STANDARD PREVIEW
(standards.iteh.ai)

SIST EN 1804-1:2002+A1:2010

<https://standards.iteh.ai/catalog/standards/sist/e6aff071-2bf8-449f-8e4a-474d09c7d86d/sist-en-1804-1-2002a1-2010>

Foreword

This document (EN 1804-1:2001+A1:2010) has been prepared by Technical Committee CEN/TC 196 "Machines for underground mines - Safety", the secretariat of which is held by DIN.

This European Standard shall be given the status of a national standard, either by publication of an identical text or by endorsement, at the latest by July 2010, and conflicting national standards shall be withdrawn at the latest by July 2010.

Attention is drawn to the possibility that some of the elements of this document may be the subject of patent rights. CEN [and/or CENELEC] shall not be held responsible for identifying any or all such patent rights.

This document includes Amendment 1, approved by CEN on 2009-12-21.

This document supersedes EN 1804-1:2001.

The start and finish of text introduced or altered by amendment is indicated in the text by tags \square_{A1} \square_{A1} .

\square_{A1} This European Standard has been prepared under a mandate given to CEN by the European Commission and the European Free Trade Association, and supports essential requirements of EU Directive(s).

For relationship with EU Directive(s), see informative Annex ZA, which is an integral part of this document. \square_{A1}

This standard is Part 1 of a European Standard specifying the safety requirements for hydraulic powered roof supports.

[SIST EN 1804-1:2002+A1:2010](https://standards.iteh.ai/catalog/standards/sist/e6aff071-2bf8-449f-8e4a-474d09c7d86d/sist-en-1804-1-2002a1-2010)

Other parts are: <https://standards.iteh.ai/catalog/standards/sist/e6aff071-2bf8-449f-8e4a-474d09c7d86d/sist-en-1804-1-2002a1-2010>

Part 2: Power set legs and rams

Part 3: Hydraulic control systems

Part 4¹⁾: Electro-hydraulic control systems

Annex A is normative.

This standard includes a Bibliography.

According to the CEN/CENELEC Internal Regulations, the national standards organizations of the following countries are bound to implement this European Standard: Austria, Belgium, Bulgaria, Croatia, Cyprus, Czech Republic, Denmark, Estonia, Finland, France, Germany, Greece, Hungary, Iceland, Ireland, Italy, Latvia, Lithuania, Luxembourg, Malta, Netherlands, Norway, Poland, Portugal, Romania, Slovakia, Slovenia, Spain, Sweden, Switzerland and United Kingdom.

1) in preparation

EN 1804-1:2001+A1:2010 (E)**Introduction**

This European Standard is a Type C-standard as stated in EN 1070.

The extent to which hazards are covered is indicated in the scope of the standard.

While producing (or when compiling) this standard it was assumed that:

- only trained and competent persons operate the machine;
- components without specific requirements are:
 - a) designed in accordance with the usual engineering practice and calculation codes;
 - b) of sound mechanical construction;
 - c) free of defects.
- components are kept in good working order;
- a negotiation took place between the user and the manufacturer concerning the use of the machinery.

iTech STANDARD PREVIEW
(standards.iteh.ai)

1 Scope

SIST EN 1804-1:2002+A1:2010

This standard specifies the safety requirements for support units when used as specified by the manufacturer or his authorised representative. Examples of support units are frame supports, chock supports, shield supports, paired frames and push-pull support systems including the components of advancing and anchoring devices which provide support functions. This part of the standard excludes fixing elements on the conveyor, coal-winning equipment, power set legs and rams, valves, hydraulic and electro-hydraulic control units, lighting and signalling facilities and other ancillary equipment.

NOTE Some components are dealt with in other parts of this standard.

This standard applies to support units used at temperatures from -10° C to 60° C.

This standard also applies to support components and support accessories which are provided if the support unit is fitted with stowing equipment. This standard identifies and takes account of:

- Possible hazards which may be caused by the operation of support units;
- Areas and operating conditions which may create such hazards;
- Hazardous situations which may cause injury or may be damaging to health;

This standard describes methods for the reduction of these hazards.

A list of hazards covered appears in clause 4.

This European standard does not establish the additional requirements for:

- Specially corrosive environments;

- Hazards occurring during construction, transportation, decommissioning;
- Earthquake.

This standard is applicable to all support units placed on the market for the first time, which are manufactured after the date on which this standard was published.

2 Normative references

This European Standard incorporates by dated or undated reference, provisions from other publications. These normative references are cited at the appropriate places in the text, and the publications are listed hereafter. For dated references, subsequent amendments to or revisions of any of these publications apply to this European Standard only when incorporated in it by amendment or revision. For undated references the latest edition of the publication referred to applies (including amendments).

EN 287-1, *Approval testing of welders - Fusion welding – Part 1: Steels*

EN 288-1, *Specification and approval of welding procedures for metallic materials – Part 1: General rules for fusion welding*

EN 288-2, *Specification and approval of welding procedures for metallic materials – Part 2: Welding procedure specification for arc welding*

EN 288-3, *Specification and approval of welding procedures for metallic materials – Part 3: Welding procedure tests for the arc welding of steels*

EN 292-1:1991, *Safety of machinery - Basic concepts - General principles for design – Part 1: Basic terminology, methodology*

EN 292-2:1991+A1:1995, *Safety of machinery - Basic concepts - General principles for design – Part 2: Technical principles and specification*

EN 1050:1996, *Safety of machinery – Principles for risk assessment*

EN 1070, *Safety of machinery – Terminology*

EN 1804-2, *Machines for underground mines - Safety requirements for hydraulic powered roof supports – Part 2: Power set legs and rams*

EN 1804-3, *Machines for underground mines - Safety requirements for hydraulic powered roof supports – Part 3: Hydraulic control systems*

ENV 1993-1-1:1992, *Eurocode 2: Design of steel structures - General rules and rules for buildings - General rules and rules for buildings*

EN 10002-1, *Metallic material - Tensile testing – Part 1: Method of test*

EN 10025:1990 + A1:1993, *Hot rolled products of non-alloy structural steels - Technical delivery conditions*

EN 10045-1, *Metallic materials - Charpy impact test – Part 1: test method*

prEN 13463-1:1999, *Non-electrical equipment for potentially explosive atmospheres – Part 1: Basic methodology and requirements*

EURONORM 103:1971, *Microscopic determination of the ferrite or austenitic grain size of steels*

EN 1804-1:2001+A1:2010 (E)**3 Terms and definitions**

For the purposes of this standard the following terms and definitions apply.

3.1**designs of hydraulic powered roof support****3.1.1****support unit**

type of hydraulic powered roof support, e.g. frame support, chock support, shield support, consisting of support components and support accessories

3.1.2**frame support**

support unit in which the canopy and the base are connected to legs arranged in a line one behind the other to form one support unit

3.1.3**chock support**

support unit in which the canopy and the base are connected to legs arranged one behind the other and side by side to form one support unit

3.1.4**shield support**

support unit in which the canopy and the base are connected additionally via a goaf shield which lies within the flow of the support bearing force

3.1.5**paired frame**

at least two support units arranged side by side moving lengthwise against each other using an advancing mechanism

3.1.6**push-pull support**

at least two support units arranged one behind the other moving lengthwise against each other using an advancing mechanism

3.2**support components**

all components which lie within the flow of the support bearing force

3.2.1**canopy**

single or composite support component which transfers the support bearing force to the roof

3.2.2**base**

single or composite support component which transfers the support bearing force to the floor

3.2.3**goaf shield**

support component intended to absorb and transfer, fully or partially, the support bearing force and forces parallel to the seam between canopy and base. It is connected to the canopy and base either directly or through a linkage. It generally shields the face area from the waste and is therefore subjected to a load from the caved material

3.3**support accessories**

all components which do not lie within the flow of the support bearing force but which are necessary for the functioning of the powered roof support

3.3.1

advancing mechanism

device attached to the support unit for moving the support forwards

3.3.2

sprag

device attached to the support unit for supporting the working face

3.3.3

forepoling device

device used to protect the face area from caving materials

3.4

anchoring device

device for preventing uncontrolled movements of the conveying and extracting machines

3.5

forces

3.5.1

yield force

force produced by an actuator at the yield pressure of the pressure limitation valve, neglecting friction

3.5.2

rated force

maximum force for which the support unit or support component is designed. It is a calculated value which is determined from the support geometry neglecting friction

3.5.3

support bearing force

force borne by a support unit normal to the strata, which is a function of the support height and which occurs at the yield force

3.5.4

test force

measured force required to be applied to the support unit or support component to ensure that it is subjected to the rated force

3.5.5

additional force

force acting on the support unit, not produced by the strata or the support components

4 List of hazards

All the items in the following list of hazards refer to continuous operation and to installation and maintenance.

This list contains the hazards and hazardous situations, as far as they are dealt with in this European Standard, identified by risk assessment significant for this type of machinery and which require action to eliminate or reduce risk.

EN 1804-1:2001+A1:2010 (E)

Table 1 — List of hazards with cross references to safety requirements

No.	EN 1050:1996	Safety requirements (clause)	Hazards
1	1.1; 1.2; 1.3	5.1.1	Crushing, shearing and cutting
2	1.9	5.1.3	fluid injection
3	17	5.4.1	Ejected parts
4	1e	5.1.6; 5.1.7; 5.3.1; 5.3.2; 5.3.4; 5.3.5; 5.3.6; 5.3.7; 5.4.1; 5.4.3; 5.5; 5.6; 5.7	Fatigue or overload
5	19; 21.1	5.1.1	Slipping, stumbling and falling in the support
6	2.4	5.4.3	Electrical energy resulting from electrostatic processes
7	7.1	5.1.2	Inhaling harmful dusts
8	7.2	5.4.2	Fire or explosion
9	8.1; 8.2	5.1.1	Neglecting ergonomic principles leading to unhealthy postures or excessive strain
10		5.1.8	Incorrect assembly
11	18; 30.1	5.2.1; 5.2.2; 5.3.7	Tipping over, unexpected loss of stability
12		5.1.4	Absence or incorrect installation of safety (protective) devices
13		5.1.5	Absence or incorrect installation or important devices and auxiliaries for erection and repair
14	1.C	5.1.5; 5.1.7; 5.1.8; 5.2.1	Potential energy of support unit parts which may move under the effect of gravity

5 Safety requirements

5.1 General requirements

Hydraulic powered roof supports, which are designed according to this part of EN 1804, shall also meet the requirements of the other parts of EN 1804.

Support units should comply as appropriate with EN 292-1:1991 and EN 292-2:1991 + A1:1995 for hazards which are not covered by this standard.

5.1.1 Access

The travel-way through the support unit shall have minimum dimensions of 0,6 m in width and 0,4 m in height with corner profiles of minimum dimensions as given in Figure 1.

The walkways shall be designed to minimise slipping hazards e.g. by the use of ribbed plates.

Dimensions in millimetres

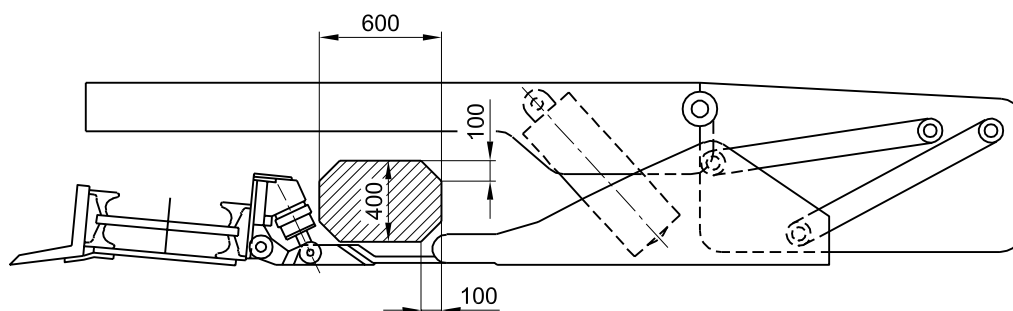

Figure 1 — Minimum travel way

5.1.2 Protection against dust

Provision shall be made in the design of support units for the installation of dust suppression equipment. That needs to be in accordance with the user's requirements (see clause 0, last indent).

NOTE Support units should be designed to seal the travel way from ingress of dust from the roof and goaf as far as possible.

iTeh STANDARD PREVIEW

5.1.3 Protection against ejected fluids (standards.iteh.ai)

Support units shall be so designed that no hydraulic elements are damaged when used as intended.

5.1.4 Protection against face material spalling

Support units having a maximum extended height of 2,5 m or more shall be fitted with devices to which sprags can be attached.

The sprags shall be positively lockable when in the retracted position.

5.1.5 Lifting and pulling points

Support units shall have lifting and pulling points.

Lifting and pulling points shall be suitable for their intended purpose. They shall be designed to have a calculated minimum factor of safety of 4 on ultimate breaking load in relation to their intended load carrying capacity. They shall be clearly and permanently marked with their load carrying capacity, e.g. by welding.

5.1.6 Forepoling devices

Forepoling devices shall not lead to damage to other parts of the support unit when loaded with the rated force.

5.1.7 Prop anchorages

Canopies of hydraulic powered roof supports shall be equipped with anchorages for the top plates of the individual hydraulic props.

EN 1804-1:2001+A1:2010 (E)**5.1.8 Correct assembly**

It shall be possible to assemble the support unit correctly in accordance with the assembly instructions provided by the manufacturer.

5.2 Stability and alignment requirements**5.2.1 Tilt-resistance**

When handled in accordance with the manufacturer's instructions support units in a freestanding state shall be stable over their whole adjustment range on all sides on a gradient of up to 15°.

In addition, they shall be stable in operation e.g. with external stabilising means.

5.2.2 Alignment

With support units for use in inclined seams with gradients of more than 30°, the alignment force (push or pull) of a support unit which is set shall be greater than the lateral weight component of three adjacent support units which are not set if these support units are no longer stable in the free-standing state.

5.3 Design requirements**5.3.1 Yield capability**

Support units shall be designed for yielding to absorb convergence between the roof and the floor. During convergence the rated force shall not be exceeded by more than 20%.

NOTE Support units should be designed in such a way that their function is impaired as little as possible by caved waste when lowering.

[SIST EN 1804-1:2002+A1:2010](https://standards.iteh.ai/catalog/standards/sist/e6aff071-2bf8-449f-8e4a-474d09c7d86d/sist-en-1804-1-2002a1-2010)

[https://standards.iteh.ai/catalog/standards/sist/e6aff071-2bf8-449f-8e4a-](https://standards.iteh.ai/catalog/standards/sist/e6aff071-2bf8-449f-8e4a-474d09c7d86d/sist-en-1804-1-2002a1-2010)

5.3.2 Behaviour when overloaded [474d09c7d86d/sist-en-1804-1-2002a1-2010](https://standards.iteh.ai/catalog/standards/sist/e6aff071-2bf8-449f-8e4a-474d09c7d86d/sist-en-1804-1-2002a1-2010)

Support components including face sprags shall be designed so that no failure occurs by bending, tension and compression when they are loaded up to 1,2 times the yield force of their respective actuators.

5.3.3 Eccentric loading

Support units shall be designed in such a way that their ability to function is not impaired in the presence of eccentric loading e.g. if the canopy is in contact with the roof on one side only.

5.3.4 Loading resulting from caving or stowing

Support units shall be capable of withstanding the caving or stowing forces resulting from over tipping when operated on a gradient when working on an over tipped face. The forces and the gradients to be expected are normally be provided by the user (see clause 0 last indent).

5.3.5 Horizontal loading

Support units shall be designed to accommodate horizontal loads.

Shield supports shall withstand a horizontal force corresponding to 0,3 times the support bearing force without any damage to the support components.

All other support units shall either withstand the forces induced by the advancing mechanism or allow relative movement between canopy and base:

- a) towards the waste, of at least 80 mm per metre of supported height and
- b) in the coal face direction and to both sides, of at least 40 mm per metre of support height.

5.3.6 Operational performance

The operational performance of the support unit shall remain unimpaired when subjected to a total of at least 26 000 load cycles with various load configurations (see A.1.3).

5.3.7 Force introduction points of legs and rams

The force introduction points of actuators shall be capable of withstanding 1,5 times the maximum tensile force and the compression force which can be generated by the support hydraulics without their function being adversely affected.

5.4 Materials

5.4.1 Steel

5.4.1.1 General

The manufacturer shall specify the steel grades and characteristics to be used.

The tensile strength of the steel grades used shall be at least 1,08 times the measured yield point or 0,2 % proof stress if the calculated stresses are more than 90 % of the permissible stresses (see 5.5).

The elongation prior to fracture A of the steel grades used shall not be less than 10 %, with the exception of steel grades used for pins where the elongation shall not be less than 9 %.

For thermal cutting of the steels, the steel manufacturer's processing specifications shall be observed.

5.4.1.2 Steel for welded support components

The steels shall be fully killed and either

- a) conform to EN 10025:1990 + A1:1993, De-oxidation type FF or
- b)
 - 1) be of grain size 6 or finer as described in EURONORM 103:1971; and
 - 2) shall have the following minimum impact values at a temperature of $-20\text{ }^{\circ}\text{C}$:
 - 20 J for steels with a 0,2 % proof stress of $< 620\text{ N/mm}^2$
 - 25 J for steels with a 0,2 % proof stress of $> 620\text{ N/mm}^2$

The values given shall be obtained regardless of the sample position, transverse or longitudinal to the direction of rolling.

The steels shall be weld able.

5.4.1.3 Steel for non-welded support components

The steels shall be killed.