



SLOVENSKI STANDARD

SIST EN 13603:2013

01-september-2013

Nadomešča:
SIST EN 13603:2004

Baker in bakrove zlitine – Preskusne metode za ocenjevanje kakovosti zaščitnih kositrovih prevlek na okroglih bakrovih vlečenih žicah za elektrotehniko

Copper and copper alloys - Test methods for assessing protective tin coatings on drawn round copper wire for electrical purposes

iTeh STANDARD PREVIEW
(standards.iteh.ai)

[SIST EN 13603:2013](https://standards.iteh.ai/catalog/standards/sist/5e3a0c23-7cac-4119-91e0-227736ad/EN-13603:2013)

[https://standards.iteh.ai/catalog/standards/sist/5e3a0c23-7cac-4119-91e0-](https://standards.iteh.ai/catalog/standards/sist/5e3a0c23-7cac-4119-91e0-227736ad/EN-13603:2013)

Ta slovenski standard je istoveten z: EN 13603:2013

ICS:

25.220.40	Kovinske prevleke	Metallic coatings
77.150.30	Bakreni izdelki	Copper products

SIST EN 13603:2013

en,fr,de

iTeh STANDARD PREVIEW
(standards.iteh.ai)

[SIST EN 13603:2013](#)

<https://standards.iteh.ai/catalog/standards/sist/5e3a0c23-7cac-4119-91e0-5aa7275736ad/sist-en-13603-2013>

EUROPEAN STANDARD

EN 13603

NORME EUROPÉENNE

EUROPÄISCHE NORM

June 2013

ICS 25.220.40; 77.150.30

Supersedes EN 13603:2002

English Version

Copper and copper alloys - Test methods for assessing protective tin coatings on drawn round copper wire for electrical purposes

Cuivre et alliages de cuivre - Méthodes d'évaluation des revêtements en étain sur les fils ronds étirés en cuivre pour usages électriques

Kupfer und Kupferlegierungen - Prüfverfahren zur Beurteilung von Schutzüberzügen aus Zinn auf gezogenen Runddrähten aus Kupfer für die Anwendung in der Elektrotechnik

This European Standard was approved by CEN on 25 April 2013.

CEN members are bound to comply with the CEN/CENELEC Internal Regulations which stipulate the conditions for giving this European Standard the status of a national standard without any alteration. Up-to-date lists and bibliographical references concerning such national standards may be obtained on application to the CEN-CENELEC Management Centre or to any CEN member.

This European Standard exists in three official versions (English, French, German). A version in any other language made by translation under the responsibility of a CEN member into its own language and notified to the CEN-CENELEC Management Centre has the same status as the official versions.

CEN members are the national standards bodies of Austria, Belgium, Bulgaria, Croatia, Cyprus, Czech Republic, Denmark, Estonia, Finland, Former Yugoslav Republic of Macedonia, France, Germany, Greece, Hungary, Iceland, Ireland, Italy, Latvia, Lithuania, Luxembourg, Malta, Netherlands, Norway, Poland, Portugal, Romania, Slovakia, Slovenia, Spain, Sweden, Switzerland, Turkey and United Kingdom.



EUROPEAN COMMITTEE FOR STANDARDIZATION
COMITÉ EUROPÉEN DE NORMALISATION
EUROPÄISCHES KOMITEE FÜR NORMUNG

Management Centre: Avenue Marnix 17, B-1000 Brussels

Contents

Page

Foreword.....	3
1 Scope	4
2 Normative references	4
3 Terms and definitions	4
4 Thickness of the unalloyed tin coating	4
5 Continuity of the tin coating	10
6 Adherence of the tin coating	12
7 Test report	14
Bibliography	15
Figures	
Figure 1 — Alternative method for supporting fine wire or wire which cannot be straightened	6
Figure 2 — Preparation of the test piece	13
Tables	
Table 1 — Test parameters	11

iTeh STANDARD PREVIEW
(standards.iteh.ai)

[SIST EN 13603:2013](https://standards.iteh.ai/catalog/standards/sist/5e3a0c23-7cac-4119-91e0-5aa7275736ad/sist-en-13603-2013)

<https://standards.iteh.ai/catalog/standards/sist/5e3a0c23-7cac-4119-91e0-5aa7275736ad/sist-en-13603-2013>

Foreword

This document (EN 13603:2013) has been prepared by Technical Committee CEN/TC 133 "Copper and copper", the secretariat of which is held by DIN.

This European Standard shall be given the status of a national standard, either by publication of an identical text or by endorsement, at the latest by December 2013, and conflicting national standards shall be withdrawn at the latest by December 2013.

Attention is drawn to the possibility that some of the elements of this document may be the subject of patent rights. CEN [and/or CENELEC] shall not be held responsible for identifying any or all such patent rights.

This document supersedes EN 13603:2002.

In comparison with EN 13603:2002, the following changes have been made:

— Editorial modifications.

Within its programme of work, Technical Committee CEN/TC 133 requested CEN/TC 133/WG 4 "Extruded and drawn products, forgings and scrap" to prepare the revision of the following standard:

EN 13603:2002, *Copper and copper alloys — Test methods for assessing protective tin coatings on drawn round copper wire for electrical purposes*

According to the CEN-CENELEC Internal Regulations, the national standards organisations of the following countries are bound to implement this European Standard: Austria, Belgium, Bulgaria, Croatia, Cyprus, Czech Republic, Denmark, Estonia, Finland, Former Yugoslav Republic of Macedonia, France, Germany, Greece, Hungary, Iceland, Ireland, Italy, Latvia, Lithuania, Luxembourg, Malta, Netherlands, Norway, Poland, Portugal, Romania, Slovakia, Slovenia, Spain, Sweden, Switzerland, Turkey and the United Kingdom.

EN 13603:2013 (E)**1 Scope**

This European Standard specifies methods for assessing the tin coating on drawn round copper wire for the manufacture of electrical conductors, e.g. according to EN 13602.

This European Standard includes test methods for the determination of the following characteristics:

- a) thickness of the unalloyed tin coating;
- b) continuity of the tin coating;
- c) adherence of the tin coating.

WARNING — This European Standard can involve the use of hazardous materials, operations, and equipment. This standard does not purport to address all of the safety problems associated with their use. It is the responsibility of the user of this standard to establish appropriate safety and health practices and determine the applicability of regulatory limitations prior to use.

2 Normative references

The following documents, in whole or in part, are normatively referenced in this document and are indispensable for its application. For dated references, only the edition cited applies. For undated references, the latest edition of the referenced document (including any amendments) applies.

EN 610, *Tin and tin alloys — Ingot tin*

iTeH STANDARD PREVIEW
(standards.iteh.ai)

3 Terms and definitions

[SIST EN 13603:2013](#)

For the purposes of this document, the following terms and definitions apply.

<https://standards.iteh.ai/catalog/standards/sist/5e3a0c23-7cac-4119-91e0-3aa7275756ad/sist-en-13603-2013>

3.1**unalloyed tin coating**

layer of pure tin on the surface of tinned wire

3.2**alloyed tin coating**

diffusion layer of copper and tin formed at the copper wire and tin coating interface during tinning and subsequent drawing and annealing processes

3.3**total tin coating**

sum of the thicknesses of the unalloyed tin coating and the alloyed tin coating

3.4**measuring area**

area of the surface over which a single measurement is made

4 Thickness of the unalloyed tin coating**4.1 Principle**

Anodic dissolution of a well-defined area of the unalloyed coating using a suitable electrolyte, followed by detection of the virtually complete dissolution of the unalloyed coating by a rapid change in cell voltage.

Calculation of the unalloyed coating thickness from the quantity of electricity (in coulombs) used, which can in turn be calculated from:

- a) the time interval between the start of the test and the first rapid change of cell voltage, if it is conducted at constant current density; or
- b) the integrated quantity of electricity used in dissolving the unalloyed coating.

4.2 Reagents and materials

4.2.1 Electrolyte, either a hydrochloric acid electrolyte or an electrolyte recommended by the instrument manufacturer.

For the hydrochloric acid electrolyte, dilute 170 ml of hydrochloric acid (HCl), $\rho = 1,18$ g/ml, to 1 000 ml with deionised water.

NOTE The unalloyed tin coating dissolves anodically at an efficiency of nearly 100 %; for determination of the electrolyte efficiency, see 4.5.6.

WARNING — Hydrochloric acid causes burns and is irritating to the respiratory system. Avoid breathing the vapour and prevent contact with eyes and skin.

This electrolyte dissolves tin coatings at very low cell voltages at which there is no anodic attack on the substrates when they are exposed at the end of the test.

4.2.2 Tin, tin grade in accordance with EN 610.

4.3 Apparatus

Suitable instruments may be constructed from readily available components. Alternatively, a proprietary instrument may be used.

4.3.1 Direct reading instruments

Proprietary direct reading instruments are available for use with electrolytes recommended by the manufacturer.

The calculation of thickness of tin coating from current density is made electronically. The instrument shall have some means of indicating when the unalloyed tin coating has been fully removed.

4.3.2 Other instruments

Instruments other than proprietary direct reading instruments record the quantity of electricity, in coulombs, used in dissolving the unalloyed coating from the measuring area, usually in arbitrary units, from which the thickness can be calculated using factors or tables.

4.3.3 Electrolytic cell

The electrolytic cell consists of a container for the electrolyte, a cathode and an anode, which is the test sample. If the container is made of metal, such as stainless steel, the container can serve as the cathode. If the container is made of insulating material, a separate cathode is required.

Also required are a device for supporting the appropriate length of the test sample and an agitation mechanism. Depending on the wire diameter, the test sample may be a straight length of wire or, if necessary to obtain sufficient surface area for smaller diameter wires, a holding device such as that shown schematically in Figure 1 is required. A magnetic stirrer or similar system shall be used to provide agitation.

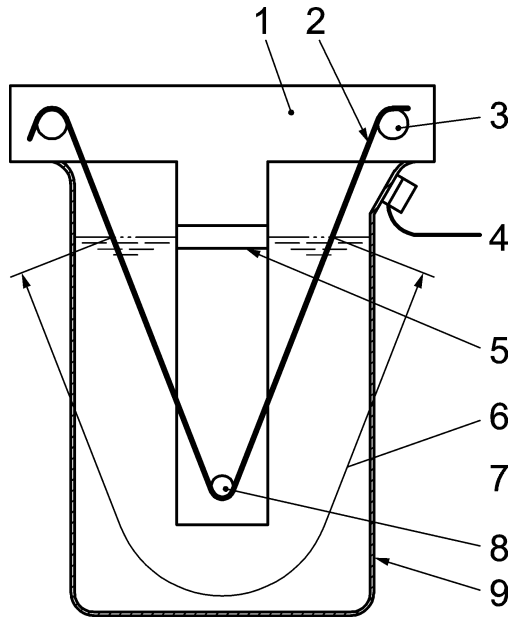
**Key**

- 1 tee-frame to support test piece of non-conducting material, manufactured from nylon or other plastics
- 2 test piece
- 3 test piece connection (anode)
- 4 cathode connection
- 5 electrolyte level
- 6 test piece length L
- 7 electrolyte
- 8 non-metallic pin
- 9 cathode (stainless steel or lead), container (beaker)

iTeh STANDARD PREVIEW
(standards.iteh.ai)

SIST EN 13603:2013

<https://standards.iteh.ai/catalog/standards/sist/5e3a0c23-7cac-4119-91e0-5aa7275736ad/sist-en-13603-2013>

Figure 1 — Alternative method for supporting fine wire or wire which cannot be straightened

4.4 Preparation of the test piece

Select a suitable length of test sample in order to provide the appropriate test piece area for exposure to the electrolyte. If necessary, clean the test surface with a suitable organic solvent (see 4.5.4.5).

Care should be taken to avoid removal of metal during the cleaning operation.

4.5 Procedure for determining the thickness of unalloyed tin coatings

4.5.1 General

If commercial equipment is used, follow the manufacturer's instructions with respect to the operating procedure for measurement, the electrolyte and, if necessary, calibration. Appropriate attention shall be given to the factors listed in 4.5.4. The performance of the instrument shall be checked using a reference specimen of pure tin wire. A tin grade in accordance with EN 610 shall be used. The test shall be carried out in accordance with 4.5.6.

If the instrument readings or the calculation of K give an electrolytic efficiency of equal to or greater than 98 %, the instrument may be used without further adjustment. Otherwise, the cause of discrepancy shall be remedied. Proprietary instruments shall be calibrated in accordance with the manufacturer's instructions.

4.5.2 Determination of measuring area

For the determination of the measuring area, the length L of the test piece in millimetres shall be determined with an accuracy of 1 % and the diameter d of the test piece for wires with a nominal diameter of $< 0,6$ mm shall be determined with an accuracy of 1 % and for wires with a nominal diameter of $\geq 0,6$ mm with an accuracy of 0,5 %. The measuring area A in square centimetres is given by the Formula (1):

$$A = \frac{d \times L \times \pi}{100} \quad (1)$$

NOTE An exact area of stripping is necessary for accuracy and the main source of error is due to the meniscus and current field at the electrolyte surface.

4.5.3 Electrolysis (Dissolution of the unalloyed tin coating)

The electrolyte (4.2.1) and test piece shall be introduced into the cell so that a known area is exposed to the electrolyte. Efforts shall be made to ensure that no gas bubbles occur on the measuring area by use of the agitation mechanism. The electrical connections shall be made and the agitator operated. Electrolysis shall be continued until dissolution of the unalloyed tin coating is complete, as indicated by a sharp change in the anode potential or cell voltage, or by the operation of the automatic cut-out.

After completion of the test, the test piece shall be removed from the cell, rinsed with water and examined to ensure that complete removal of the unalloyed tin coating has occurred over the measuring area (see 4.5.4.9).

4.5.4 Factors affecting the measuring accuracy

4.5.4.1 Coating thickness

The optimum accuracy is achieved with coating thicknesses in the range 0,2 μm up to 50 μm .

[https://standards.iteh.ai/catalog/standards/sist/5e3a0c23-7cac-4119-91e0-](https://standards.iteh.ai/catalog/standards/sist/5e3a0c23-7cac-4119-91e0-5aa7275736ad/sist-en-13603-2013)

4.5.4.2 Current variation

[5aa7275736ad/sist-en-13603-2013](https://standards.iteh.ai/catalog/standards/sist/5e3a0c23-7cac-4119-91e0-5aa7275736ad/sist-en-13603-2013)

For instruments using the constant current and time measuring technique, current variation will cause errors. For instruments using a current-time integrator, too large a change in current can change the anode current efficiency or interfere with the end-point, causing an error.

4.5.4.3 Area variation

The accuracy of the thickness measurement will be no better than the accuracy to which the measuring area is known. Area variations due to electrolyte level (excessive agitation), can lead to measurement errors. In some cases it can be advantageous to measure the length after electrolysis is complete and re-calculate the area.

4.5.4.4 Agitation

Agitation (i.e. the rate of stirring) shall be sufficient to remove any gas bubbles formed during the test, which can adhere to the test piece or cathode. Excessive agitation shall be avoided to prevent interference with the length of test piece submerged.

4.5.4.5 Condition of the test piece surface

Oil, grease, paint, corrosion products, staining or other surface chemical treatments can interfere with the test.

4.5.4.6 Cleanliness of the cell

Deposition of tin can take place on the cathode in some electrolytes. This deposit can alter the cell voltages. It is, therefore, essential to keep the cathode clean.