



Designation: E 1962 – 04

# Standard Test Method for Ultrasonic Surface Examinations Using Electromagnetic Acoustic Transducer (EMAT) Techniques<sup>1</sup>

This standard is issued under the fixed designation E 1962; the number immediately following the designation indicates the year of original adoption or, in the case of revision, the year of last revision. A number in parentheses indicates the year of last reapproval. A superscript epsilon ( $\epsilon$ ) indicates an editorial change since the last revision or reapproval.

## 1. Scope

1.1 This test method covers guidelines for utilizing EMAT techniques for detecting material discontinuities that are primarily open to the surface (for example, cracks, seams, laps, cold shuts, laminations, through leaks, lack of fusion). This technique can also be sensitive to flaws and discontinuities that are not surface-breaking, provided their proximity to the surface is less than or equal to the Rayleigh wave length.

1.2 This test method covers procedures for the non-contact coupling of surface waves into a material via electromagnetic fields.

1.3 The procedures of this test method are applicable to any material in which acoustic waves can be introduced electromagnetically. This includes any material that is either electrically conductive or ferromagnetic, or both.

1.4 This test method is intended to provide examination capabilities for in-process, final, and maintenance applications.

1.5 This test method does not provide standards for the evaluation of derived indications. Interpretation, classification, and ultimate evaluation of indications, albeit necessary, are beyond the scope of this test method. Separate specifications or agreement will be necessary to define the type, size, location, and direction of indications considered acceptable or non-acceptable.

1.6 The values stated in inch-pound units are to be regarded as the standards. The SI units given in parentheses are for information only.

1.7 *This standard does not purport to address all of the safety concerns, if any, associated with its use. It is the responsibility of the user of this standard to establish appropriate safety and health practices and determine the applicability of regulatory limitations prior to use.*

<sup>1</sup> This test method is under the jurisdiction of ASTM Committee E07 on Nondestructive Testing and is the direct responsibility of Subcommittee E07.06 on Ultrasonic Method.

Current edition approved May 1, 2004. Published May 2004. Originally approved in 1998. Last previous edition approved in 1998 as E 1962 - 98.

## 2. Referenced Documents

### 2.1 ASTM Standards:<sup>2</sup>

E 543 Practice for Agencies Performing Nondestructive Testing

E 587 Practice for Ultrasonic Angle-Beam Examination by the Contact Method

E 1316 Terminology for Nondestructive Examinations

E 1774 Guide to Electromagnetic Acoustic Transducers (EMATs)

E 1816 Practice for Ultrasonic Examinations Using Electromagnetic Acoustic Transducer (EMAT) Techniques

### 2.2 ANSI/ASNT Standards:

Recommended Practice SNT-TC-1A Personnel Qualification and Certification in Nondestructive Testing<sup>3</sup>

ANSI/ASNT CP-189 Standard for Qualification and Certification of Nondestructive Testing Personnel<sup>3</sup>

### 2.3 Military Standard:

MIL-STD-410 Nondestructive Testing Personnel Qualification and Certification<sup>4</sup>

## 3. Terminology

### 3.1 Definitions:

3.1.1 Additional related terminology is defined in Terminology E 1316.

### 3.2 Definitions of Terms Specific to This Standard:

3.2.1 *electromagnetic acoustic transducer (EMAT)*—an electromagnetic device for converting electrical energy into acoustical energy in the presence of a magnetic field.

3.2.2 *Lorentz forces*—applied to electric currents when placed in a magnetic field. Lorentz forces are perpendicular to both the direction of the magnetic field and the current direction. Lorentz forces are the forces responsible behind the principle of electric motors.

<sup>2</sup> For referenced ASTM standards, visit the ASTM website, www.astm.org, or contact ASTM Customer Service at service@astm.org. For *Annual Book of ASTM Standards* volume information, refer to the standard's Document Summary page on the ASTM website.

<sup>3</sup> Available from American National Standards Institute (ANSI), 25 W. 43rd St., 4th Floor, New York, NY 10036.

<sup>4</sup> Available from U.S. Government Printing Office Superintendent of Documents, 732 N. Capitol St., NW, Mail Stop: SDE, Washington, DC 20401.

3.2.3 *magnetostrictive forces*—forces arising from magnetic domain wall movements within a magnetic material during magnetization.

3.2.4 *meander coil*—an EMAT coil consisting of periodic, winding, non-intersecting, and usually evenly-spaced conductors.

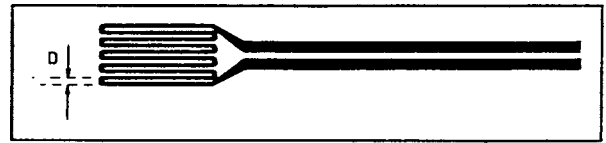

FIG. 2 Typical EMAT Meander Coil for Generation of Surface Waves

**4. Summary of Test Method**

4.1 The techniques outlined in this test method address the electromagnetic generation of Rayleigh acoustic wave modes for sensitivity to surface or near-surface flaws or discontinuities. Flaws are detected by reflection or attenuation of acoustic waves from interactions at discontinuity interfaces.

4.2 Fig. 1 shows one typical EMAT setup for the generation of Rayleigh waves. An external magnetic induction  $B_0$  parallel to the surface is applicable on ferromagnetic material. The magnetic field may be generated by a permanent magnet, a pulsed magnet, or a DC electromagnet. A meander RF coil is oriented in the plane of and near the surface of the object to be tested. The magnetic field lines are tangential to the coil and perpendicular to the conductor. The coil is excited by an RF toneburst pulse produced by a specialized EMAT pulser. A surface current is induced in the test sample by transformer action. The surface current interacts with the external magnetic field by means of the Lorentz force. This disturbance is transferred to the lattice of the solid and is thus the ultrasonic source responsible for producing the surface acoustic waves. As shown in Fig. 1, an ordinary meander coil produces bidirectional waves. In practice, specially designed meander coils can be designed to produce unidirectional waves.

4.3 Fig. 2 illustrates a typical meander coil for generation of surface waves. The following relationship must be valid for Rayleigh wave generation with a meander coil:

$$V_R = 2Df \tag{1}$$

where:

- $V_R$  = Rayleigh wave velocity,
- $D$  = separation of adjacent conductors, and
- $f$  = frequency.

4.4 Surface flaws or discontinuities lead to reflection or attenuation of the surface waves. Either pulse-echo or pitch-catch modes can be used. Upon approaching the receiver

EMAT, the reflected or attenuated ultrasonic waves produce oscillations within the conductor in the presence of the magnetic field and thus induce a voltage in the receiver coil (similar to an electric generator) allowing detection.

**5. Significance and Use**

5.1 EMAT techniques show benefits and advantages over conventional piezoelectric ultrasonic techniques in special applications where flexibility in the type of wave mode generation is desired. EMATs are highly efficient in the generation of surface waves.

5.2 Since EMATs are highly efficient in the generation of surface waves, and since acoustic techniques utilizing surface waves are proven effective for detecting surface and near-surface discontinuities, they should be considered for any applications where conventional penetrant testing and magnetic particle NDT techniques are effective but undesirable.

5.3 Since EMAT techniques are non-contacting, they should be considered for ultrasonic examinations where applications involve automation, high-speed inspections, moving objects, applications in remote or hazardous locations, applications to objects at elevated temperatures, or objects with rough surfaces.

5.4 The purpose of this test method is to promote the EMAT technique of the ultrasonic method as a viable alternative to conventional PT and MPT methods for detecting the presence of surface and near-surface material discontinuities.

5.5 The use of EMATs and the selection of appropriate operating parameters presuppose a knowledge of the geometry of the component; the probable location, size, orientation, and reflectivity of the expected flaws; the allowable range of EMAT lift-off; and the laws of physics governing the propagation of ultrasonic waves. This procedure pertains to a specific EMAT surface inspection application.

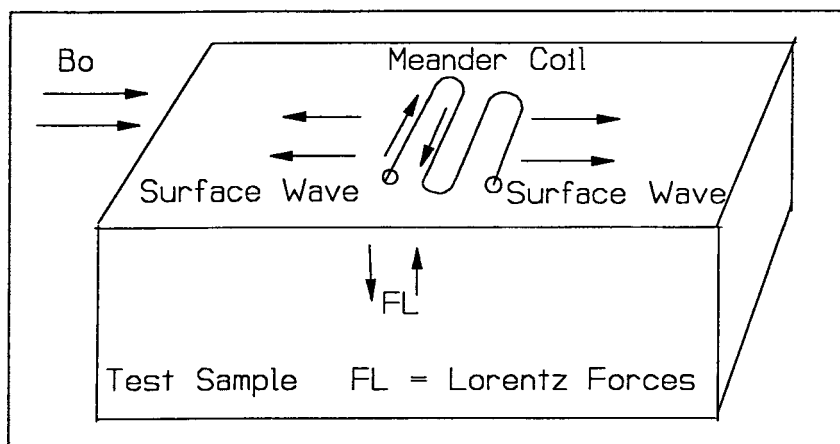

FIG. 1 Typical EMAT Configuration for Rayleigh Wave Generation

**6. Basis of Application**

6.1 The following items are subject to contractual agreement between the parties using or referencing the standard:

6.1.1 *Personnel Qualification*

6.1.1.1 *If specified in the contractual agreement*, personnel performing examination to this test method shall be qualified in accordance with a nationally or internationally recognized NDT personnel qualification practice or standard such as ANSI/ASNT-CP-189, SNT-TC-1A, MIL STD-410, or a similar document and certified by the employer or certifying agency, as applicable. The practice or standard used and its applicable revision shall be identified in the contractual agreement between the using parties.

6.1.2 *Qualification of Nondestructive Agencies*—If specified in the contractual agreement, NDT agencies shall be qualified and evaluated as described in Practice E 543. The applicable edition of Practice E 543 shall be specified in the contractual agreement.

6.1.3 *Procedures and Techniques*—The procedures and techniques to be utilized shall be as specified in the contractual agreement.

6.1.4 *Surface Preparation*—The pre-examination surface preparation criteria shall be in accordance with 10.2.2 unless otherwise specified.

6.1.5 *Timing and Extent of Examination*—Shall be specified in the contractual agreement

6.1.6 *Reporting Criteria/Acceptance Criteria*—Reporting criteria for the examination results shall be in accordance with Section 12 unless otherwise specified. Acceptance criteria shall be specified in the contractual agreement.

6.1.7 *Reexamination of Repaired/Re-Worked Items*—Reexamination of repaired/re-worked items is not addressed in this test method and, if required, shall be specified in the contractual agreement.

**7. Techniques**

7.1 This test method describes three separate techniques for EMAT surface wave examination. The first involves pulse-echo or pitch-catch techniques for the detection of reflected surface waves. The second technique involves a pitch-catch method sensitive to the attenuation of surface waves. The third technique involves surface wave diffraction with focused meander coils.

7.2 *Pulse-Echo or Pitch-Catch Reflected Surface Wave Technique*—These techniques are analogous to conventional ultrasonic techniques. The techniques use either one (pulse-echo) or two (pitch-catch) EMAT sensors and rely upon the reception of reflected surface waves from the flaw. The advantage of these techniques is simplicity. One disadvantage is the difficulty in detecting all flaw orientations without elaborate scanning routines. Also, when these techniques are used for weld applications, a problem arises in that the root and crown of the weld can produce reflections that are prominent enough to interfere with and even obscure flaw signals. When such interferences are apparent, it is recommended that one of the other two techniques described herein be utilized to avoid these problems.

7.3 *Pitch-Catch Attenuation Technique*—The attenuation technique is most effectively applied using the arrangement of sensors illustrated in Fig. 3. The technique indicates the presence of a flaw by noting attenuation of the UT signal. The sensors use small permanent magnets to generate narrow surface wave beams that cross at right angles. The preferred technique requires two channels of EMAT instrumentation although it may be modified for one-channel operation. To implement one-channel operation, the distance between one transmitter receiver pair is increased slightly to displace the two received signals in time. The transmitter coils are then wired in series and the receiver coils are wired in series. This arrangement allows both pairs of EMAT coils to be used with one channel of EMAT instrumentation. One advantage to the attenuation technique is sensitivity to all flaw orientations. Another advantage to using the attenuation technique is the ability to scan both sides of a weld simultaneously. It also scans large areas of the material in one scan. A disadvantage relates to the beam width, which must be narrow or focused in order to achieve a minimum of 6 dB of attenuation.

7.4 *Diffraction Technique*—The basis of the diffraction technique is illustrated in Fig. 4. Two collinear focused EMATs (transmitter and receiver) or one pulse-echo EMAT are positioned at an angle (the diffraction angle) with respect to the normal to the weld centerline. The weld root and crown act as a specular reflector whose signals are reflected away from the EMAT receiver. The flaw is, however, detected over a wide angular range by means of diffraction. Depending upon the size of the flaw relative to the ultrasonic wavelength, it acts as either a point diffractor or a series of point diffractors. A natural flaw such as a fatigue crack has a series of facets and branches that act as point diffractors. Therefore, it is typically possible to detect the presence of a natural flaw several inches long with this technique. Surface waves can be focused to a region approximating a point focus (a region approaching a wavelength as a limit). It is frequently advantageous to have a reasonable focal depth to increase the area covered with each linear scan. For many welds, it is possible to scan one half of the weld crown from each side of the weld. A single EMAT sensor is sensitive to all orientations except possibly a crack

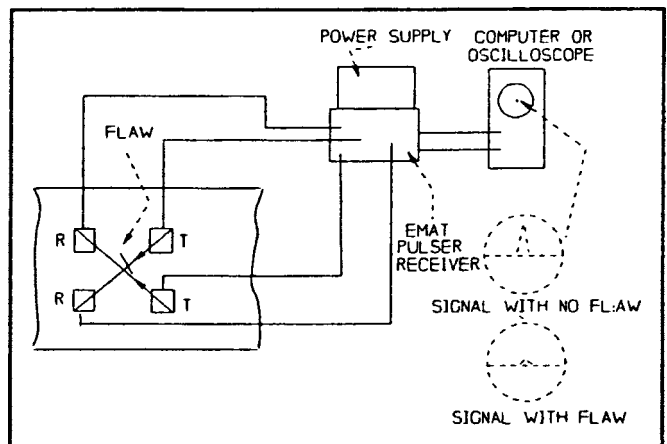

FIG. 3 Attenuation Technique

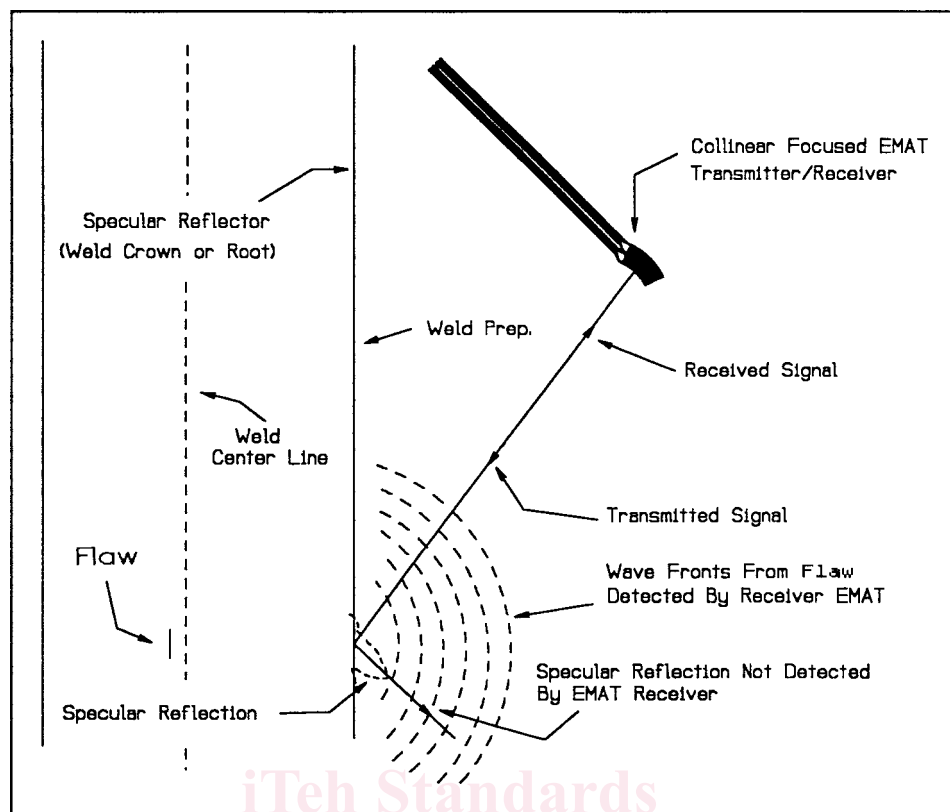

FIG. 4 The Diffraction Technique

<https://standards.iteh.ai>

parallel to the incident beam. Therefore, two sensors with positive and negative diffraction angles will be sensitive to all flaw orientations.

## 8. Apparatus

8.1 The apparatus may be considered to consist of the EMAT sensor and the EMAT instrumentation. The sensor consists of an RF coil and a source of magnetic field. The instrumentation consists of a tone burst pulser/receiver, a data acquisition system or display device such as an oscilloscope, an impedance matching network, a preamplifier (preferred), and a well shielded cable from the pulser/receiver to the sensor.

### 8.2 Coil Design:

8.2.1 A meander coil is used to produce surface waves. Coil design and conductor spacing required to produce a given frequency has been discussed in 4.3. The coil may be focused or nonfocused depending upon the technique being used and the desired resolution and sensitivity. Fig. 5 gives an example of typical design parameters for a focused coil, similar to that used for the diffraction technique. Many EMAT coils are flexible printed circuits produced by photoetching on a polyamide substrate. The surface of the coil can be backed with a thin layer of foam and covered with a thin (0.001 to 0.005 in.) wearplate of high molecular weight polyethylene or titanium. The purpose of the wearplate is to maintain a constant lift-off for the EMAT coil. The wearplate should be pliable and conform to irregular or curved surfaces. The polyamide substrate usually has a thickness of 0.001 or 0.002 in. For “as welded” crowns, the selected frequency for any of the tech-

niques should be no greater than necessary in order to minimize the response to surface roughness from the weld.

8.2.2 A typical operating frequency for the diffraction technique is 1 MHz. A typical frequency used for the attenuation technique is 2 MHz. A coil that might be used for the attenuation technique is shown in Fig. 6. The extensions to the polyamide substrate fasten to the magnet keeper in the mechanical fixture.

8.3 *Coil Excitation*—A high-power, specialized RF generator is necessary to provide excitation to the coil in the form of a toneburst of several cycles.

8.4 *Magnetization*—Neodymium iron boron permanent magnets can be used for all EMAT surface wave techniques. Typical dimensions of the magnets and the direction of the magnetic induction  $B$  is shown in Fig. 7 for the attenuation and diffraction techniques. The direction of  $B$  is perpendicular to both the RF coil and the examination surface. The permanent magnets allow compact sensors to be used for field applications, however, pulsed or DC electromagnets could also be used, if applicable. The field direction could be either parallel or perpendicular to the conductor inspection surface for ferromagnetic materials or perpendicular to the inspection surface for nonferromagnetic conductors.

8.5 *Instrumentation*—The signal processing and data acquisition electronics should consist of a receiver section to provide for adjustable gain and filtering for the EMAT signals. Conventional ultrasonic instruments can be used for this purpose. The user has several options to capture and analyze the EMAT