

International Standard



4210

INTERNATIONAL ORGANIZATION FOR STANDARDIZATION • МЕЖДУНАРОДНАЯ ОРГАНИЗАЦИЯ ПО СТАНДАРТИЗАЦИИ • ORGANISATION INTERNATIONALE DE NORMALISATION

Cycles — Safety requirements of bicycles

Cycles — Conditions de sécurité des bicyclettes

First edition — 1980-08-01

UDC 629.118.3 : 614.8

Ref. No. ISO 4210-1980 (E)

Descriptors : road vehicles, bicycles, safety requirements, protuberances, brakes (motion arresters), steering control devices, cycle frames, vehicle wheels, tyres, pedals, tests, braking tests, impact tests.

Price based on 20 pages

FOREWORD

ISO (the International Organization for Standardization) is a worldwide federation of national standards institutes (ISO member bodies). The work of developing International Standards is carried out through ISO technical committees. Every member body interested in a subject for which a technical committee has been set up has the right to be represented on that committee. International organizations, governmental and non-governmental, in liaison with ISO, also take part in the work.

Draft International Standards adopted by the technical committees are circulated to the member bodies for approval before their acceptance as International Standards by the ISO Council.

International Standard ISO 4210 was developed by Technical Committee ISO/TC 149, *Cycles*, and was circulated to the member bodies in April 1978.

It has been approved by the member bodies of the following countries :

Australia	India	South Africa, Rep. of
Austria	Israel	Switzerland
Belgium	Italy	Thailand
Brazil	Japan	Turkey
Canada	Korea, Rep. of	United Kingdom
Chile	Mexico	USA
Czechoslovakia	Netherlands	USSR
France	Poland	
Germany, F.R.	Romania	

The member body of the following country expressed disapproval of the document on technical grounds :

Ireland

Contents	Page
0 Introduction	1
1 Scope	1
2 Field of application	1
3 Reference	1
4 Definitions	1
 Section one : Requirements of sub-assemblies	
5 General	2
6 Brakes	2
7 Steering	3
8 Frame/fork assembly	4
9 Front fork	4
10 Wheels	4
11 Tyres and tubes	4
12 Pedals	4
13 Saddle	5
14 Chain	6
15 Chainguard	6
16 Lighting and reflectors	6
17 Warning device	6
18 Instructions	6
19 Marking	7
 Section two : Requirements of complete bicycle	
20 Road test	7
 Section three : Test methods	
21 Brake block test	7
22 Brake system load test	7
23 Braking performance test	10
24 Back-pedal brake linearity test	11
25 Steering assembly test	11

26	Impact tests on frame/fork assembly	14
27	Static load test (wheel)	15
28	Pedal tests	15
29	Static load test (saddle and pillar)	17
30	Road test	17

Annexes

A	Explanation of method of obtaining "best fit" line and 20 % limit lines for back-pedal brake linearity test	18
B	Steering geometry	20

Cycles — Safety requirements of bicycles

0 INTRODUCTION

In producing this International Standard, the aim has been to ensure that bicycles manufactured in compliance with it will be as safe as is practically possible. The tests have been designed to ensure the strength and durability of individual parts as well as of the bicycle as a whole, demanding high quality throughout and consideration of safety aspects from the design stage onwards.

Notwithstanding the requirements specified in this International Standard, any new designs, constructions, materials and methods of assembly which give an equivalent degree of safety and durability may be regarded as complying with this International Standard subject to approval by a representative and recognized authority and pending the issue of an amendment to, or extension of, this International Standard.

The scope has been limited to safety considerations, and has specifically avoided standardization of components.

1 SCOPE

This International Standard specifies safety and performance requirements for the design, assembly and testing of bicycles and sub-assemblies, and lays down guidelines for instructions on the use and care of bicycles.

2 FIELD OF APPLICATION

This International Standard applies to bicycles intended for use on public roads, and on which the saddle can be adjusted to provide a saddle height of 635 mm or more.

It does not apply to specialized types of bicycle such as tradesmen's delivery bicycles, tandems, toy bicycles and bicycles designed and equipped for use in sanctioned competitive events.

3 REFERENCE

ISO/R 1101/1, *Tolerances of form and of position — Part 1: Generalities, symbols, indications on drawings.*

4 DEFINITIONS

For the purposes of this International Standard, the following definitions apply :

4.1 cycle : Any vehicle that has at least two wheels and is propelled solely by the muscular energy of the person on that vehicle, in particular by means of pedals.

4.2 bicycle : A two-wheeled cycle.

4.3 delivery bicycle : A bicycle designed for the primary purpose of carrying goods.

4.4 tandem : A bicycle with saddles for two or more riders, one behind the other.

4.5 saddle height : The dimension from the ground plane to the top of the saddle, measured in the centre of the seating area normal to the ground plane when the bicycle is in the upright position.

4.6 braking distance : The distance travelled in bringing a bicycle to rest from the moment of application of the brakes.

4.7 stopping distance : The sum of the braking distance and the distance travelled during the rider's reaction time.

4.8 gear development : The distance travelled by a bicycle during one revolution of the pedal cranks.

4.9 exposed protrusion: A protrusion that can be contacted by the central 75 mm of the lateral surface of a cylinder 250 mm long and 83 mm in diameter (simulating a limb). See figure 1.

4.10 tread surface (pedal): The surface of a pedal that is presented to the underside of the foot, and whose design incorporates a slip-resistant characteristic.

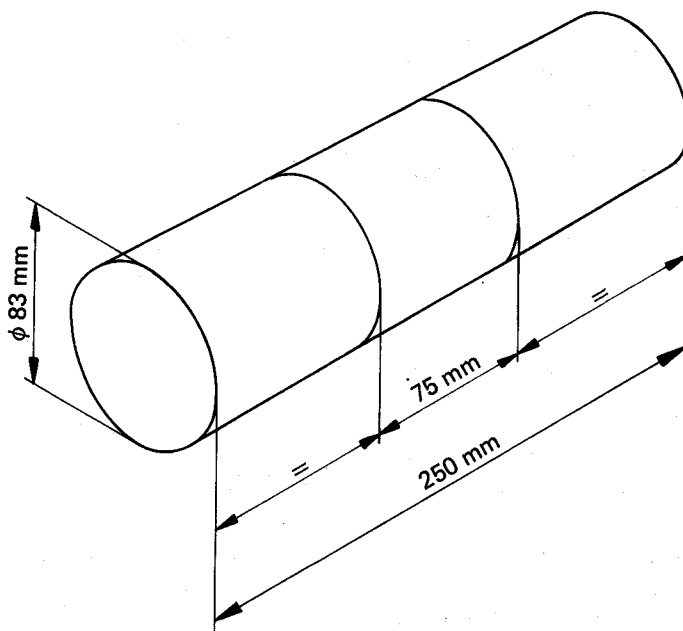

FIGURE 1 — Exposed protrusion test cylinder

SECTION ONE REQUIREMENTS OF SUB-ASSEMBLIES

5 GENERAL

5.1 Sharp edges

Exposed edges that could come into contact with the rider's hands, legs, etc., during normal riding or normal handling and normal maintenance shall not be sharp.

5.2 Protrusions

Any exposed protrusion longer than 8 mm after assembly shall terminate in a radius of not less than 6,3 mm. Such protrusions shall have a major end dimension greater than 12,7 mm and a minor end dimension greater than 3,2 mm.

There shall be no protrusions on the top tube of a bicycle frame between the saddle and a point 300 mm forward of the saddle, with the exception that control cables no greater than 6,4 mm in diameter and cable clamps made from material no thicker than 4,8 mm may be attached to the top tube.

A screw thread that is an exposed protrusion (see 4.9) shall be limited to a protrusion length of one major diameter of the screw beyond the internally threaded mating part.

6 BRAKES

6.1 Braking system

A bicycle shall be equipped with a braking system, or systems, to ensure compliance with 6.5. Where one braking system is provided, this shall operate on the rear wheel; where two separate systems are provided, one shall operate on the front wheel and one on the rear wheel.

6.2 Hand-operated brakes

6.2.1 Brake lever position

The brake levers for front and rear brakes shall be positioned on that side of the handlebar appropriate to the country in which the bicycle is to be used.

6.2.2 Brake lever dimensions

The maximum dimension between the brake lever and the handlebar grip measured to the outside surfaces of lever and grip shall not exceed 90 mm at any point between the cable end of the lever and the lever's midpoint. The dimension may increase toward the open end of the lever but shall not exceed 100 mm except for the last 20 mm of the lever.

6.2.3 Cable-brake assembly

When a bicycle is equipped with cable brakes, the screws for attaching to the frame or fork shall be provided with a suitable locking device, for example lockwasher, locknut or stiffnut.

The brake system shall operate without binding.

The cable pinch-bolt shall not cut any of the cable strands, when assembled to the manufacturer's instructions.

6.2.4 Brake pad assembly

The brake friction pad shall be securely attached to the backing plate or holder and there shall be no failure of the friction pad assembly when tested by the method specified in clause 21. The brake system shall be capable of meeting the braking performance requirements of 6.5.1 and 6.5.2 after completion of the test specified in clause 21.

6.2.5 Brake adjustment

The brakes shall be capable of adjustment to an efficient operating position until the brake pads have worn to the point of requiring replacement as recommended in the literature provided by the manufacturer.

When correctly adjusted, the brake pad shall not contact anything other than the intended braking surface.

6.3 Back-pedal brakes

The brake shall be actuated by the operator's foot applying force to the pedal in a direction opposite to that of the drive force. The brake mechanism shall function independently of any drive-gear positions or adjustments. The differential between the drive and brake positions of the crank shall not exceed 60°. The measurement shall be taken with the crank held against each position with a torque of at least 14 N·m.

6.4 Strength of brake system

6.4.1 Hand-operated brakes

When tested by the method described in 22.1, there shall be no failure of the brake system or of any component thereof.

6.4.2 Back-pedal brakes

When tested by the method described in 22.2, there shall be no failure of the brake system or any component thereof.

6.5 Braking performance

6.5.1 Braking under dry conditions

When tested by the method described in clause 23 :

- a) a bicycle having a gear development, in its highest gear, of 5 m or more shall be brought to a smooth safe stop within a distance of 5,5 m from a velocity of 24 km/h;
- b) a bicycle having a gear development, in its highest gear, of less than 5 m shall be brought to a smooth safe stop within a distance of 5,5 m from a velocity of 16 km/h.

NOTE — The braking distance of 5,5 m includes a margin of human and instrument error associated with current test methods, and may be reviewed at a later date in the light of experience gained in testing.

6.5.2 Braking under wet conditions

[Requirements will be added later.]

6.5.3 Linearity of back-pedal brake

When tested by the method described in clause 24, the brake force shall be linearly proportional (within 20 %) to a pedal force of from 90 to 300 N and shall be not less than 150 N for a pedal force of 300 N.

7 STEERING

7.1 Handlebars

The handlebars shall have an overall width between 350 and 700 mm. The vertical distance between the top of the handlebar grips in their highest position and the seat surface of the saddle in its lowest position shall not exceed 400 mm.

The ends of the handlebars shall be fitted with handgrips or end plugs that will withstand a removal force of 70 N.

7.2 Handlebar stem

The handlebar stem shall contain a permanent mark that clearly indicates the minimum insertion depth of the handlebar stem into the fork stem, or alternatively a positive and permanent means of ensuring the minimum insertion depth shall be provided. The insertion mark, or insertion depth, shall be not less than 2,5 times the shaft diameter from the lower end of the stem, and there shall be at least one shaft diameter's length of contiguous circumferential shaft material below the mark. An insertion mark shall not detract from the strength of the handlebar stem.

7.3 Expander bolt for handlebar stem

The minimum failure torque of the bolt shall be at least 50 % greater than the manufacturer's maximum tightening torque.

7.4 Steering stability

The steering shall be free to turn through at least 60° either side of the straight-ahead position and shall exhibit no tight spots, stiffness or slackness in the bearings when correctly adjusted.

A minimum of 25 % of the total weight of the bicycle and rider shall act on the front wheel when the rider is holding the handlebar grips and sitting on the saddle, with the saddle and rider in their most rearward positions.

Recommendations for steering geometry are given in annex B.

7.5 Strength of steering assembly

The handlebar stem shall be capable of withstanding without fracture the tests described in 25.1.1 and 25.1.2.

When tested by the method described in 25.2, there shall be no movement of the handlebar relative to the stem.

When tested by the method described in 25.3, there shall be no movement of the handlebar stem relative to the fork stem other than that movement required to take up tolerances before any locking faces abut. Such movement shall not exceed 5°.

8 FRAME/FORK ASSEMBLY

8.1 Impact test (falling mass)

When tested by the method described in 26.1, there shall be no visible evidence of fracture, and the permanent deformation of the assembly, measured between the centre-lines of the axles, shall not exceed 40 mm.

8.2 Impact test (falling frame/fork assembly)

When tested by the method described in 26.2, there shall be no visible evidence of fracture.

9 FRONT FORK

The slots or other means of location for the front axle within the front fork shall be such that when the axle or cones are firmly abutting the top face of the slots, the front wheel remains central within the front fork.

10 WHEELS

10.1 Rotational trueness

This is defined in ISO/R 1101/1 in terms of the measure-

ment of run-out under rotation. The run-out tolerances given below represent the maximum permissible variation of position of the rim (i.e. full indicator reading) of a fully assembled wheel during one complete revolution about the axle without axial movement.

10.1.1 Concentricity tolerance

For bicycles equipped with rim brakes, the run-out shall not exceed 2 mm when measured perpendicular to the axle at a suitable point along the rim. For bicycles not equipped with rim brakes, the run-out shall not exceed 4 mm.

10.1.2 Squareness tolerance

For bicycles equipped with rim brakes, the run-out shall not exceed 2 mm when measured parallel to the axle at a suitable point along the rim. For bicycles not equipped with rim brakes, the run-out shall not exceed 4 mm.

10.2 Clearance

Alignment of the wheel assembly in a bicycle shall allow not less than 2 mm clearance between the tyre and any frame or fork element.

10.3 Static load test

When a fully assembled wheel is tested by the method described in clause 27, there shall be no failure of any of the components of the wheel, and the permanent deformation, measured at the point of application of the force on the rim, shall not exceed 1,5 mm.

11 TYRES AND TUBES

11.1 Inflation pressure

The inflation pressure recommended by the manufacturer shall be moulded on the sidewall of the tyre so as to be readily visible when the latter is assembled on the wheel.

Non-moulded tyres are excluded from this requirement.

11.2 Compatibility

The tyre and tube shall be compatible with the rim design. When inflated to 110 % of the recommended inflation pressure for a period of not less than 5 min, the tyre shall remain intact on the rim.

12 PEDALS

12.1 Tread

12.1.1 The tread surface of a pedal shall be secured against movement within the pedal assembly.

12.1.2 Pedals intended to be used without toe-clips, or for optional use with toe-clips, shall have

- a) tread surfaces on the top and bottom surfaces of the pedal, or
- b) a definite preferred position that automatically presents a tread surface to the rider's foot.

12.1.3 Pedals designed to be used only with toe-clips shall have toe-clips securely attached, and need not have tread surfaces.

12.2 Pedal clearance

12.2.1 Ground clearance

With the bicycle unladen, the pedal at its lowest point and the tread surface of the pedal parallel to the ground and uppermost where it has only one tread surface, the bicycle shall be capable of being leaned over at an angle of 25° from the vertical before any part of the pedal touches the ground.

When a bicycle is equipped with a sprung suspension, this measurement shall be taken with the suspension in a depressed position such as would be caused by a rider weighing 85 kg.

12.2.2 Toe clearance

Bicycles not equipped with positive foot-retaining devices (such as toe clips) shall have at least 89 mm clearance between the pedal and the front tyre or mudguard (when turned to any position). The clearance shall be measured forward and parallel to the longitudinal axis of the bicycle from the centre of either pedal to the arc swept by the tyre or mudguard, whichever results in the least clearance. See figure 2.

Where a bicycle front fork has features that are designed to permit the fitting of a front mudguard, the toe clearance shall be measured with a suitable mudguard so fitted.

12.3 Static load test

When tested by the method described in 28.1, there shall be no visible fracture in any part of the pedal axle or pedal frame.

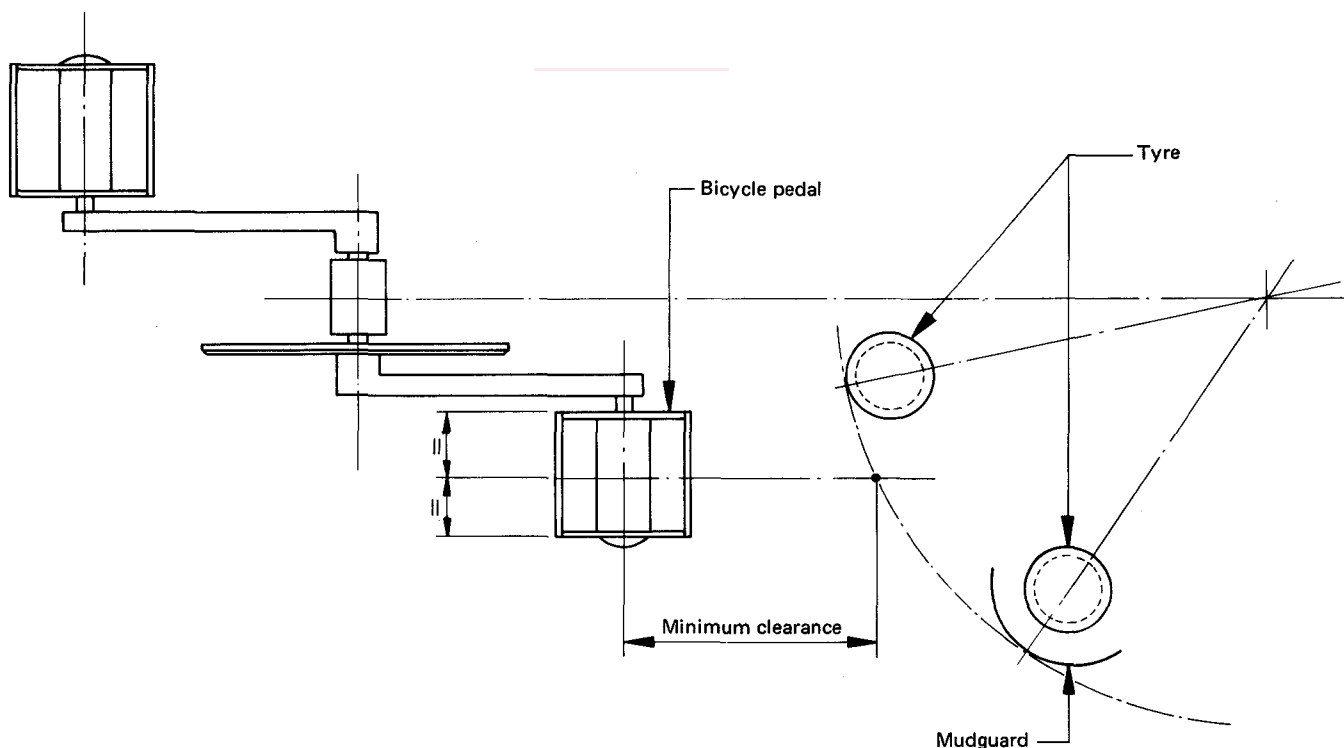

FIGURE 2 — Toe clearance

12.4 Kinetic test

When tested by the method described in 28.2, there shall be no visible fracture of the pedal axle after approximately 1 000 000 revolutions of the test shaft.

13 SADDLE

13.1 Limiting dimensions

No part of the saddle, saddle supports, or accessories attached to the saddle shall be more than 125 mm above the top saddle surface at the point where the saddle surface is intersected by the seat post axis.

13.2 Saddle pillar

The saddle pillar shall contain a permanent mark that clearly indicates the minimum insertion depth of the pillar into the frame. The insertion mark shall be not less than two diameters of the pillar, measured from the bottom of the full diameter of the pillar, and it shall not detract from the strength of the pillar.

13.3 Saddle adjustment clamps

When tested by the method described in clause 29, there shall be no movement of the saddle clamp in any direction with respect to the pillar, or of the pillar with respect to the frame.

Saddles which are not clamped, but are designed to pivot in a vertical plane with respect to the pillar, shall be allowed to move within the parameters of the design and shall withstand the test described in clause 29 without failure.

14 CHAIN

Where a chain drive is used as a means of transmitting the motive force, the chain shall operate over front and rear sprockets without binding.

The chain shall have a minimum breaking load of 8 010 N.

15 CHAINGUARD

A bicycle shall be equipped with a protective device shielding the upper junction of the chain and chain wheel (drive sprocket) against the entrapment of clothing or body parts. The device shall shield the chain for a distance of at least 25 mm measured prior to the point of engagement of the chain with the chain wheel.

16 LIGHTING AND REFLECTORS

16.1 Lighting

The provision of front or rear lamps, or of a complete lighting system, is not mandatory for the purposes of this International Standard, but where fitted this shall be in accordance with the appropriate legislation of the country in which the bicycle is to be used, or, in the absence of such legislation, shall comply with the requirements of a forthcoming International Standard¹⁾.

16.2 Reflectors

Reflectors shall be fitted to comply with appropriate legislation of the country in which the bicycle is to be used, or, in the absence of such legislation, shall comply with the requirements of a forthcoming International Standard¹⁾.

17 WARNING DEVICE

A bell or other suitable audible warning device may be fitted; where fitted, it shall comply with appropriate legislation of the country in which the bicycle is to be used, or, in the absence of such legislation, shall comply with the requirements of a forthcoming International Standard.

18 INSTRUCTIONS

Each bicycle shall be provided with a set of instructions containing information on :

- a) preparation for riding — how to measure and adjust the seat height and handlebar height to suit the rider, with an explanation of the warning marks on seat pillar and handlebar stem;
- b) recommended tightening of fasteners related to handlebar, handlebar stem, saddle and pillar, and wheels;
- c) lubrication — where and how often to lubricate, and recommended lubricant;
- d) correct chain tension and how to adjust this;
- e) adjustment of brakes and recommendations for replacement of brake blocks;
- f) adjustment of gears;
- g) normal spares, i.e. tyres, tubes, brake-block holder assembly;

1) The requirements for lighting and reflective devices of bicycles will form the subject of ISO 6742.

h) accessories — where these are offered as fitted, details should be included such as operation, maintenance required (if any) and relevant spares (i.e. light bulbs);

j) recommendations on safe riding — regular checks on brakes, tyres, steering and lighting; caution concerning increased braking distance in wet weather.

Any other relevant information may be included at the discretion of the manufacturer.

19 MARKING

Where a manufacturer claims compliance with this International Standard, each bicycle shall be visibly and durably marked with :

- a) the number of this International Standard, i.e. ISO 4210;
- b) the manufacturer's name or code.

SECTION TWO REQUIREMENTS OF COMPLETE BICYCLE

20 ROAD TEST

When tested by the method described in clause 30, there shall be no system or component failure and no loosening or misalignment of the seat, handlebars, controls or reflectors.

The bicycle shall exhibit stable handling in turning and steering, and it shall be possible to ride with one hand removed from the handlebar (as when giving hand signals), without difficulty of operation or hazard to the rider.

SECTION THREE TEST METHODS

21 BRAKE BLOCK TEST

The test shall be conducted on a fully assembled bicycle with the brakes adjusted to a correct position, and with a rider weighing 70 kg, or an equivalent mass, on the saddle. Each brake lever shall be actuated with a force of 180 N, which is maintained during the test.

The bicycle shall then be subject to five forward and five rearward movements, each of not less than 75 mm distance.

- a) a cable-brake lever into contact with the handlebar grip, or with the handlebar in the absence of a grip;
- b) a cable-brake extension lever level with the upper surface of the handlebars or in contact with the handlebars;
- c) a rod-operated brake lever level with the upper surface of the handlebar grip.

This test shall be repeated for a total of ten times on each handbrake lever.

22 BRAKE SYSTEM LOAD TEST

22.1 Hand-operated brake

This test shall be conducted on a fully assembled bicycle. After it has been ensured that the braking system is correctly adjusted, a force shall be applied to the brake lever at a point 25 mm from the end of the lever and in a direction normal to the handlebar grip in the plane of travel of the lever, as shown in figure 3. This force shall be 450 N, or such lesser force as is required to bring :

22.2 Back-pedal brake

This test shall be conducted on a fully assembled bicycle. After it has been ensured that the braking system is correctly adjusted, and with the pedal cranks in a horizontal position, as shown in figure 4, a force shall be applied to the centre of the left-hand pedal axle. This force shall be 1 500 N, gradually applied, in a vertical direction, and shall be maintained fully for 15 s.

This test shall be repeated for a total of ten times.