



Designation: D4045 – 04

# Standard Test Method for Sulfur in Petroleum Products by Hydrogenolysis and Rateometric Colorimetry<sup>1</sup>

This standard is issued under the fixed designation D4045; the number immediately following the designation indicates the year of original adoption or, in the case of revision, the year of last revision. A number in parentheses indicates the year of last reapproval. A superscript epsilon ( $\epsilon$ ) indicates an editorial change since the last revision or reapproval.

## 1. Scope\*

1.1 This test method covers the determination of sulfur in petroleum products in the range from 0.02 to 10.00 mg/kg.

1.2 This test method may be extended to higher concentration by dilution.

1.3 This test method is applicable to liquids whose boiling points are between 30 and 371°C (86 and 700°F). Materials that can be analyzed include naphtha, kerosine, alcohol, steam condensate, various distillates, jet fuel, benzene, and toluene.

1.4 The values stated in SI units are to be regarded as standard. The values given in parentheses are for information only.

1.4.1 Certain specifications for the recorder (see 5.5) are excepted.

1.5 *This standard does not purport to address all of the safety concerns, if any, associated with its use. It is the responsibility of the user of this standard to establish appropriate safety and health practices and determine the applicability of regulatory limitations prior to use.*

## 2. Referenced Documents

2.1 *ASTM Standards:*<sup>2</sup>

D1193 Specification for Reagent Water

D6299 Practice for Applying Statistical Quality Assurance and Control Charting Techniques to Evaluate Analytical Measurement System Performance

## 3. Summary of Test Method

3.1 The sample is injected at a constant rate into a flowing hydrogen stream in a hydrogenolysis apparatus. The sample and hydrogen are pyrolyzed at a temperature of 1300°C, or above, to convert sulfur compounds to hydrogen sulfide (H<sub>2</sub>S). Readout is by the rateometric detection of the colorimetric

reaction of H<sub>2</sub>S with lead acetate. Condensable components are converted to gaseous products, such as methane, during hydrogenolysis.

## 4. Significance and Use

4.1 In many petroleum refining processes, low levels of sulfur in feed stocks may poison expensive catalysts. This test method can be used to monitor the amount of sulfur in such petroleum fractions.

4.2 This test method may also be used as a quality-control tool for sulfur determination in finished products.

## 5. Apparatus<sup>3,4</sup>

5.1 *Pyrolysis Furnace*—A furnace that can provide an adjustable temperature from 900 to 1400°C in a 5-mm inside diameter or larger tube is required to pyrolyze the sample. The furnace entry temperature shall allow insertion of the hypodermic tip to a depth at which the temperature is 550°C to provide sample vaporization at the injection syringe tip. This temperature shall be above the boiling point of the sample and of the sulfur compounds in the sample (see Fig. 1). The pyrolyzer tube may be of quartz; however, the lifetime is limited above 1250°C. Ceramic may be used at any temperature.

5.2 *Rateometric H<sub>2</sub>S Readout*—Hydrogenolysis products contain H<sub>2</sub>S in proportion to sulfur in the sample. The H<sub>2</sub>S is measured by measuring rate of change of reflectance caused by darkening when lead sulfide is formed. Rateometric electronics, adapted to provide a first derivative output, allows sufficient sensitivity to measure below 0.1 mg/L (see Fig. 2).

5.3 *Hypodermic Syringe*—A hypodermic having a needle long enough to reach the 550°C zone is required. A side port is convenient for vacuum filling and for flushing the syringe. A 100- $\mu$ L syringe is satisfactory for injection rates down to 3  $\mu$ L/min and a 25- $\mu$ L syringe for lower rates. (**Warning**—Exercise caution as hypodermics can cause accidental injury.)

<sup>1</sup> This test method is under the jurisdiction of ASTM Committee D02 on Petroleum Products and Lubricants and is the direct responsibility of Subcommittee D02.03 on Elemental Analysis.

Current edition approved May 1, 2004. Published June 2004. Originally approved in 1987. Last previous edition approved in 1999 as D4045-99. DOI: 10.1520/D4045-04.

<sup>2</sup> For referenced ASTM standards, visit the ASTM website, www.astm.org, or contact ASTM Customer Service at service@astm.org. For *Annual Book of ASTM Standards* volume information, refer to the standard's Document Summary page on the ASTM website.

<sup>3</sup> The apparatus described in 5.1-5.4 inclusive is similar in specification to the equipment available from Houston Atlas, Inc., 22001 North Park Dr., Kingswood, TX 77339-3804. For further information see Drushel, H. V., "Trace Sulfur Determination Petroleum Fractions," *Analytical Chemistry*, Vol 50, 1978, p. 76.

<sup>4</sup> The sole source of supply of the apparatus known to the committee at this time is Houston Atlas, Inc. If you are aware of alternative suppliers, please provide this information to ASTM International Headquarters. Your comments will receive careful consideration at a meeting of the responsible technical committee,<sup>1</sup> which you may attend.

\*A Summary of Changes section appears at the end of this standard.

SF-111ab-2

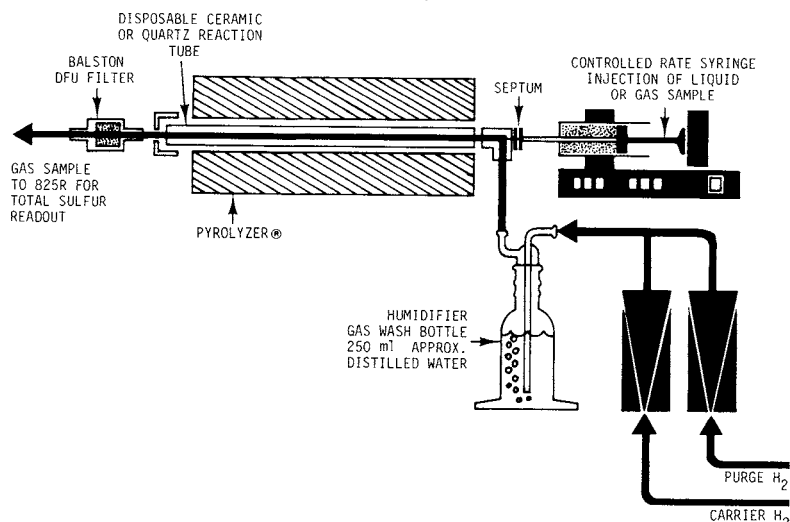

NOTE—The humidifier gas wash bottle is optional.

FIG. 1 Hydrogenolysis Flow Diagram

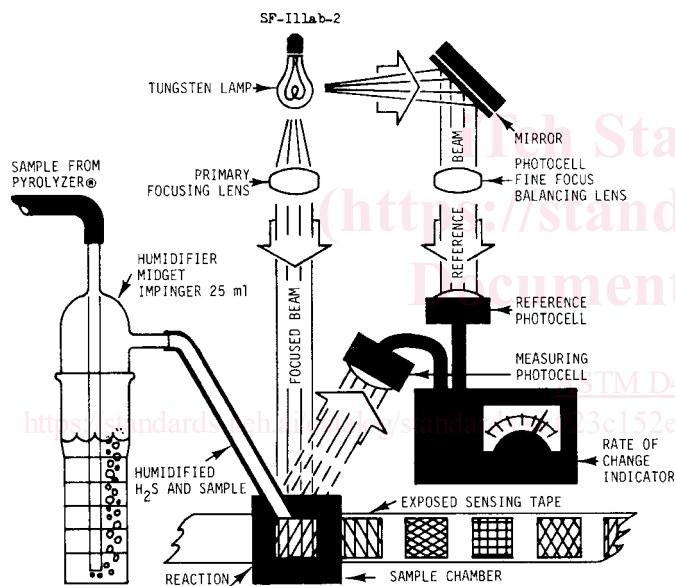

FIG. 2 Photorateometry H<sub>2</sub>S Readout

5.4 *Syringe Injection Drive*—The drive shall provide uniform, continuous sample injections. Variation in drive injection rate caused by mechanical irregularities of gears will cause noise. The adjustable drive shall be capable of injection from 6  $\mu\text{L}/\text{min}$  to 0.06  $\mu\text{L}/\text{min}$  over a 6-min interval.

5.5 *Recorder*—A chart recorder with 10-V full scale and 10 000- $\Omega$  input or greater and having a chart speed of 0.2 to 1 in./min (approximately 0.5 to 3 cm/min) is required. An attenuator can be used for more sensitive recorders. Newer instruments that display the results are acceptable in lieu of a chart recorder.

5.6 *Thermocouple*—A thermocouple suitable for use at 500 to 1400°C, 250-mm long with readout is required. Type K,  $\frac{1}{16}$ -in. (1.6-mm) diameter, Type 316 stainless steel sheath is suitable.

## 6. Reagents and Materials

6.1 *Purity of Reagents*—Reagent grade chemicals shall be used in all tests. Unless otherwise indicated, it is intended that all reagents conform to the specifications of the Committee on Analytical Reagents of the American Chemical Society where such specifications are available.<sup>5</sup> Other grades may be used, provided it is first ascertained that the reagent is of sufficiently high purity to permit its use without lessening the accuracy of the determination.

6.2 *Purity of Water*—Unless otherwise indicated, references to water shall be understood to mean Type II reagent grade water conforming to Specification D1193.

6.3 *Sensing Tape*—Lead acetate impregnated paper of chromatographic quality shall be used. (**Warning**—Lead is a cumulative poison.)

6.4 *Hydrogen*—As no commercial grade of hydrogen has a sulfur specification sufficiently low, each new source of supply must be tested. A change in the zero base line of 5 % of full scale from no flow to full flow indicates impure hydrogen. (**Warning**—Extremely flammable gas under pressure. Hydrogen is a flammable gas. Test all flow systems for leaks and purge with inert gas before introducing hydrogen and after removing hydrogen. Keep all flow systems as small in volume as practical and provide protective screening for containers other than sample flow lines. Dispose of exhaust gases in a fume hood or by vacuuming to a safe area. If gas cylinders are used handle carefully as rupture of the valve or cylinder is dangerous.)

### 6.5 Reference Standards:

<sup>5</sup> *Reagent Chemicals, American Chemical Society Specifications*, American Chemical Society, Washington, DC. For Suggestions on the testing of reagents not listed by the American Chemical Society, see *Annual Standards for Laboratory Chemicals*, BDH Ltd., Poole, Dorset, U.K., and the *United States Pharmacopeia and National Formulary*, U.S. Pharmacopeial Convention, Inc. (USPC), Rockville, MD.