



SLOVENSKI STANDARD
SIST EN 12851:2006+A1:2010
01-junij-2010

Nadomešča:
SIST EN 12851:2006

Stroji za predelavo hrane - Priključki za stroje z dodatno gonilno gredjo - Varnostne in higienske zahteve (vključno z dopolnilom A1)

Food processing machinery - Catering attachments for machines having an auxiliary drive hub - Safety and hygiene requirements

Nahrungsmittelmaschinen - Großküchen-Vorsatzgeräte - Sicherheits- und Hygieneanforderungen

Machines pour les produits alimentaires - Accessoires pour machines ayant une prise de mouvement auxiliaire - Prescriptions relatives à la sécurité et à l'hygiène

Ta slovenski standard je istoveten z: EN 12851:2005+A1:2010

ICS:

67.260	Tovarne in oprema za živilsko industrijo	Plants and equipment for the food industry
--------	--	--

SIST EN 12851:2006+A1:2010 en,fr

iTeh STANDARD PREVIEW
(standards.iteh.ai)

SIST EN 12851:2006+A1:2010

<https://standards.iteh.ai/catalog/standards/sist/0459e91d-e3bc-4ff1-a8c9-538ac237b35e/sist-en-12851-2006a1-2010>

EUROPEAN STANDARD

EN 12851:2005+A1

NORME EUROPÉENNE

EUROPÄISCHE NORM

March 2010

ICS 67.260

Supersedes EN 12851:2005

English Version

Food processing machinery - Catering attachments for machines having an auxiliary drive hub - Safety and hygiene requirements

Machines pour les produits alimentaires - Accessoires pour machines ayant une prise de mouvement auxiliaire - Prescriptions relatives à la sécurité et à l'hygiène

Nahrungsmittelmaschinen - Großküchen-Vorsatzgeräte - Sicherheits- und Hygieneanforderungen

This European Standard was approved by CEN on 28 July 2005 and includes Amendment 1 approved by CEN on 17 January 2010.

CEN members are bound to comply with the CEN/CENELEC Internal Regulations which stipulate the conditions for giving this European Standard the status of a national standard without any alteration. Up-to-date lists and bibliographical references concerning such national standards may be obtained on application to the CEN Management Centre or to any CEN member.

This European Standard exists in three official versions (English, French, German). A version in any other language made by translation under the responsibility of a CEN member into its own language and notified to the CEN Management Centre has the same status as the official versions.

CEN members are the national standards bodies of Austria, Belgium, Bulgaria, Croatia, Cyprus, Czech Republic, Denmark, Estonia, Finland, France, Germany, Greece, Hungary, Iceland, Ireland, Italy, Latvia, Lithuania, Luxembourg, Malta, Netherlands, Norway, Poland, Portugal, Romania, Slovakia, Slovenia, Spain, Sweden, Switzerland and United Kingdom.

<https://standards.iteh.ai/catalog/standards/sist/0459c91d-c5bc-4ff1-a8c9-538ac237b35e/sist-en-12851-2006a1-2010>



EUROPEAN COMMITTEE FOR STANDARDIZATION
COMITÉ EUROPÉEN DE NORMALISATION
EUROPÄISCHES KOMITEE FÜR NORMUNG

Management Centre: Avenue Marnix 17, B-1000 Brussels

Contents

Foreword.....	3
Introduction	4
1 Scope	5
2 Normative references	5
3 Terms, definitions and description	6
3.1 Terms and definitions	6
3.2 Description	6
4 List of significant hazards	12
4.1 General.....	12
4.2 Mechanical hazards	12
4.3 Incorrect assembly and fitting.....	13
4.4 Handling, cleaning and storage of cutting devices.....	13
4.5 Hazards generated by neglecting hygiene principles in the attachment design.....	13
4.6 Hazards generated by neglecting ergonomic principles in attachment design	13
4.7 Compatibility of the attachment with the driving machine	13
5 Safety and hygiene requirements and/or A1 protective A1 measures	14
5.1 General.....	14
5.2 Mechanical hazards	14
5.3 Incorrect assembly and fitting.....	21
5.4 Handling, cleaning and storage of cutting devices.....	21
5.5 Hygiene	21
5.6 Ergonomics	23
5.7 Compatibility between the attachment and the driving machine	24
6 Verification of the safety and hygiene requirements and/or measures	24
7 Information for use	24
7.1 General.....	24
7.2 Instruction handbook	24
7.3 Marking	26
Annex A (normative) Principles of design to ensure the cleanability of catering attachments	27
Annex ZA (informative) A1 Relationship between this European Standard and the Essential Requirements of EU Directive 98/37/EC A1	40
Annex ZB (informative) A1 Relationship between this European Standard and the Essential Requirements of EU Directive 2006/42/EC A1	41
Bibliography	42

Foreword

This document (EN 12851:2005+A1:2010) has been prepared by Technical Committee CEN /TC 153, "Machinery intended for use with foodstuffs and feed" the Secretariat of which is held by DIN.

This European Standard shall be given the status of a national standard, either by publication of an identical text or by endorsement, at the latest by September 2010, and conflicting national standards shall be withdrawn at the latest by September 2010.

This document includes Amendment 1, approved by CEN on 2010-01-17.

This document supersedes EN 12851:2005.

Attention is drawn to the possibility that some of the elements of this document may be the subject of patent rights. CEN [and/or CENELEC] shall not be held responsible for identifying any or all such patent rights.

The start and finish of text introduced or altered by amendment is indicated in the text by tags $\boxed{A_1}$ $\boxed{A_1}$.

$\boxed{A_1}$ This document has been prepared under a mandate given to CEN by the European Commission and the European Free Trade Association, and supports essential requirements of EU Directive(s).

For relationship with EU Directive(s), see informative Annexes ZA and ZB, which are integral parts of this document. $\boxed{A_1}$

iTeh STANDARD PREVIEW
(standards.iteh.ai)

It is one of a series of standards on the design and construction of machines used in the catering industry:

- vegetable cutting machines; <https://standards.iteh.ai/catalog/standards/sist/0459e91d-e3bc-4ff1-a8c9-538ac237b35e/sist-en-12851-2006a1-2010>
- catering attachments for machines having an auxiliary drive hub;
- food processors and blenders;
- hand-held blenders and whisks;
- beam mixers;
- salad dryers;
- vegetable peelers;
- cooking kettles equipped with powered stirrer and/or mixer.

According to the CEN/CENELEC Internal Regulations, the national standards organizations of the following countries are bound to implement this European Standard: Austria, Belgium, Bulgaria, Croatia, Cyprus, Czech Republic, Denmark, Estonia, Finland, France, Germany, Greece, Hungary, Iceland, Ireland, Italy, Latvia, Lithuania, Luxembourg, Malta, Netherlands, Norway, Poland, Portugal, Romania, Slovakia, Slovenia, Spain, Sweden, Switzerland and United Kingdom.

EN 12851:2005+A1:2010 (E)**Introduction**

The use of attachments involves various mechanical hazards and the attachments themselves need to meet food hygiene requirements.

A catering attachment is a mechanical device which takes its motive power from a unit which is not part of the attachment. Some attachments are dedicated to a particular motive power source from the same manufacturers; others are designed to be used on a range of machines and power units from any manufacturer.

A1 Their extensive use in numerous countries justifies the need of a standard covering both safety and the hazards to food hygiene. **A1**

This European Standard is a type C standard as stated in EN ISO 12100-1.

The machinery concerned and the extent to which hazards, hazardous situations and events are covered are indicated in the scope of this document.

When provisions of this type C standard are different from those which are stated in type A or B standards, the provisions of this type C standard take precedence over the provisions of the other standards, for machines that have been designed and built according to the provisions of this type C standard.

ITeH STANDARD PREVIEW
(standards.iteh.ai)

SIST EN 12851:2006+A1:2010

<https://standards.iteh.ai/catalog/standards/sist/0459e91d-e3bc-4ff1-a8c9-538ac237b35e/sist-en-12851-2006a1-2010>

1 Scope

1.1 This European Standard specifies the safety and hygiene requirements for the design and manufacture of the following catering attachments intended to be connected to an auxiliary drive hub of machines used in catering (mainly but not exclusively planetary mixers) and to be used in the commercial and institutional catering industry:

- vegetable cutters and cheese graters;
- worm type attachments:
 - fruit squeezers;
 - meat mincers;
 - pasta extruders;
 - coffee grinder;
- strip cutters;
- planetary mixers and whippers;
- potato-mashers.

1.2 This European Standard deals with all significant hazards, hazardous situations and events relevant to catering attachments, when they are used as intended and under the conditions of misuse which are reasonably foreseeable by the manufacturer. It deals with the hazards due to the use, the maintenance, the cleaning, removal of jammed food, feeding and changing the tool (see Clause 4).

1.3 This European Standard is not applicable to:

- catering attachments which are exclusively part of the equipment of the machines they are intended for (as optional or standard equipment);
- the driving machines for which the attachments are intended (but the standard deals with the interface of the attachments with these machines);
- attachments including electrical equipment.



1.4 Noise is not dealt with in this European Standard.

1.5 This European Standard is not applicable to catering attachments which are manufactured before the date of its publication as EN.

2 Normative references

The following referenced documents are indispensable for the application of this document. For dated references, only the edition cited applies. For undated references, the latest edition of the referenced document (including any amendments) applies.

 deleted text 

 EN 614-1:2006 , *Safety of machinery — Ergonomic design principles — Part 1: Terminology and general principles*

EN 1672-2:2005, *Food processing machinery — Basic concepts — Part 2: Hygiene requirements*

EN 12851:2005+A1:2010 (E)

EN 61310-1, *Safety of machinery — Indication, marking and actuation — Part 1: Requirements for visual, auditory and tactile signals (IEC 61310-1:1995)*

EN ISO 4287, *Geometrical product specifications (GPS) — Surface texture: Profile method — Terms, definitions and surface texture parameters (ISO 4287:1997)*

EN ISO 12100-1:2003, *Safety of machinery — Basic concept, general principles for design — Part 1: Basic terminology, methodology (ISO 12100-1:2003)*

EN ISO 12100-2:2003, *Safety of machinery — Basic concept, general principles for design — Part 2: Technical principles (ISO 12100-2:2003)*

Ⓐ₁ EN ISO 13857:2008, *Safety of machinery — Safety distances to prevent hazard zones being reached by the upper limbs (ISO 13857:2008)* Ⓐ₁

3 Terms, definitions and description**3.1 Terms and definitions**

For the purposes of this European Standard, the terms and definitions given in EN ISO 12100-1:2003 and the following apply.

3.1.1**pusher device**

non removable device assisting feeding, hinged to the hopper or other part of the attachment

3.1.2**plunger device**

device assisting feeding, which is removable. [SIST EN 12851:2006+A1:2010
https://standards.iteh.ai/catalog/standards/sist/0459e91d-e3bc-4ff1-a8c9-538ac237b35e/sist-en-12851-2006a1-2010](https://standards.iteh.ai/catalog/standards/sist/0459e91d-e3bc-4ff1-a8c9-538ac237b35e/sist-en-12851-2006a1-2010)

3.2 Description

Attachments essentially consist of two parts:

a) A part common to all attachments which includes:

- a device which engages on a drive shaft from the driving machine;
- devices for fastening and positioning the attachment on the power drive machine either directly or via an adapter which allows the attachment to fit to other connecting systems (or to other machines).

b) A part specific to the attachment which includes the tools. The main components of this part can be:

1) for vegetable cutting attachments and cheese grater (see Figure 1):

- a housing (5) into which a cutting device is inserted, the cutting device can be a blade (9) with or without a grid (3);
- a cover (4) incorporating the product feed device which is fixed to the housing;
- a feed device which may be a feed hopper (6) with pusher device (1) and/or plunger device (2);
- disc, cylinder or cone fitted with cutting/grating device of variable size (11) (the vegetable cutting attachment can be equipped with such tools), for cheese graters.

Food product is loaded into the feed device and held against to the cutting device by manual pressure on the pusher or plunger. When the food is cut, it falls from the housing via the delivery chute (10) into a receptacle which is not part of the machine.

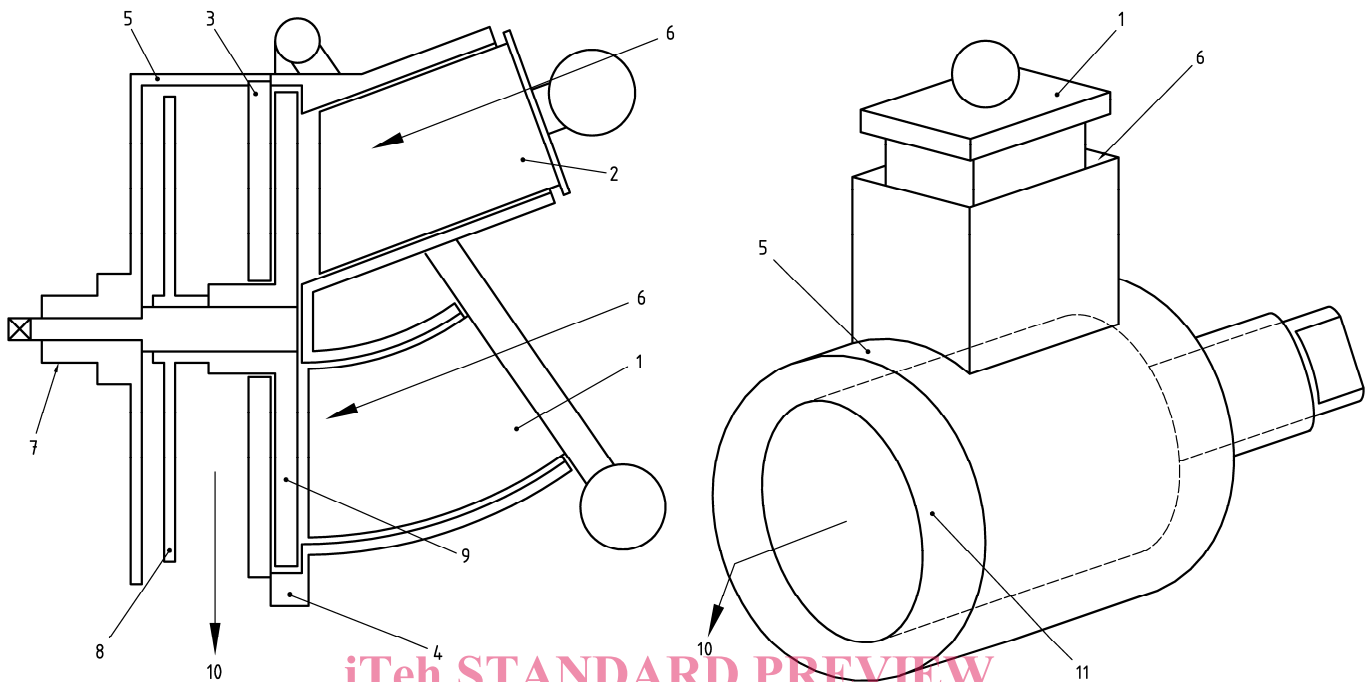
**Key**

- 1 Pusher device
- 2 Plunger device
- 3 Fixed grid
- 4 Cover
- 5 Housing
- 6 Feed hopper
- 7 Drive connection to the power source
- 8 Ejector
- 9 Cutter
- 10 Delivery chute

Key

- 1 Plunger device
- 5 Housing
- 6 Feed hopper
- 10 Delivery chute
- 11 Cutting/grating device

a) Description of a vegetable cutting attachment**b) Description of a cheese grater****Figure 1 — Description of a vegetable cutting attachment and a cheese grater**

2) for worm type attachments (see Figure 2):

- body (3) with a tray (2) equipped with a plunger device(1);
- worm with sieve (4) for worm-type fruit squeezers;
- worm and knife (5) which rotates in relation to a fixed grid (6) for meat mincer;
- worm which directly provides coffee feed and grinding for coffee grinders;
- feed worm leading to a die which gives the relevant shape to the product for pasta extruders;
- two mills with adjustable gap (one fixed, one rotating) included in a body with feed hopper and discharge chute (see Figure 2.c).

EN 12851:2005+A1:2010 (E)

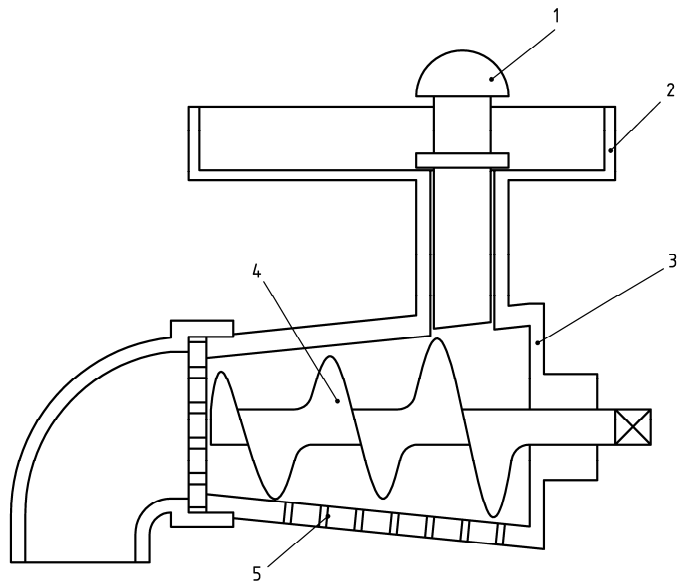

- Key**
- 1 Plunger device
 - 2 Tray
 - 3 Body
 - 4 Worm
 - 5 Sieve

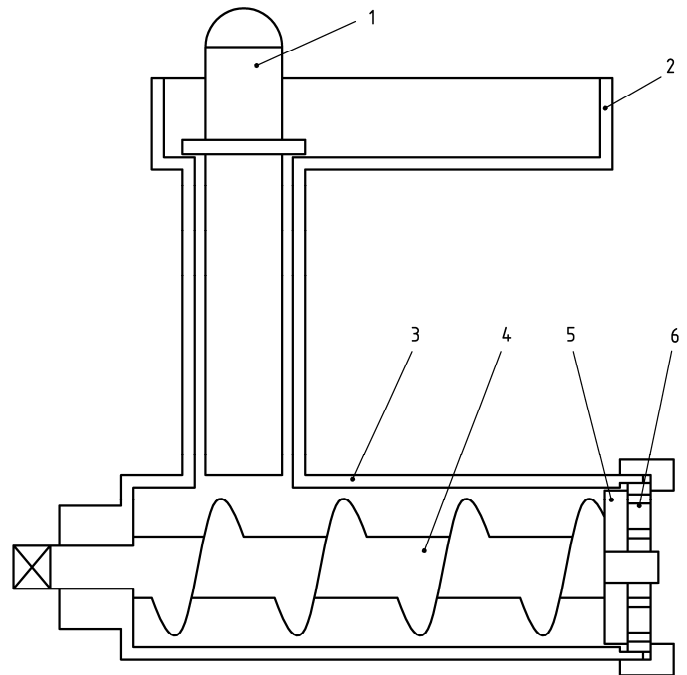

- Key**
- 1 Plunger device
 - 2 Tray
 - 3 Body
 - 4 Worm
 - 5 Knife
 - 6 Fixed grid

iTeh STANDARD PREVIEW
(standards.iteh.ai)

SIST EN 12851:2006+A1:2010
<https://standards.iteh.ai/catalog/standards/sist/0497c91d-e3bc-4ff1-a8c9-538ac237b35e/sist-en-12851-2006a1-2010>

a) Description of a worm type fruit squeezer

b) Description of a meat mincer

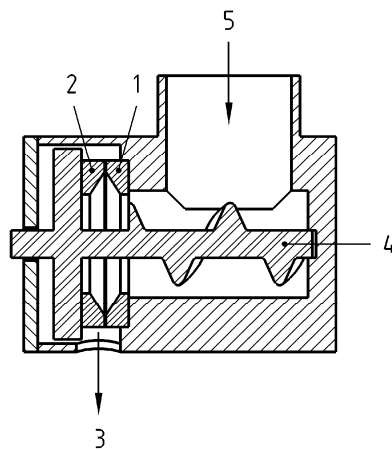

- Key**
- 1 Fixed mill
 - 2 Rotating mill
 - 3 Delivery chute
 - 4 Worm
 - 5 Feed hopper

c) Description of a coffee grinder

Figure 2 — Description of worm type attachments

3) for strip cutters (see Figure 3):

- a body with a feed hopper (1) and a delivery chute (3) including sets of circular counter rotating knives (2).

iTeh STANDARD PREVIEW **(standards.iteh.ai)**

[SIST EN 12851:2006+A1:2010](https://standards.iteh.ai/catalog/standards/sist/0459e91d-e3bc-4ff1-a8c9-538ac237b35e/sist-en-12851-2006a1-2010)

<https://standards.iteh.ai/catalog/standards/sist/0459e91d-e3bc-4ff1-a8c9-538ac237b35e/sist-en-12851-2006a1-2010>

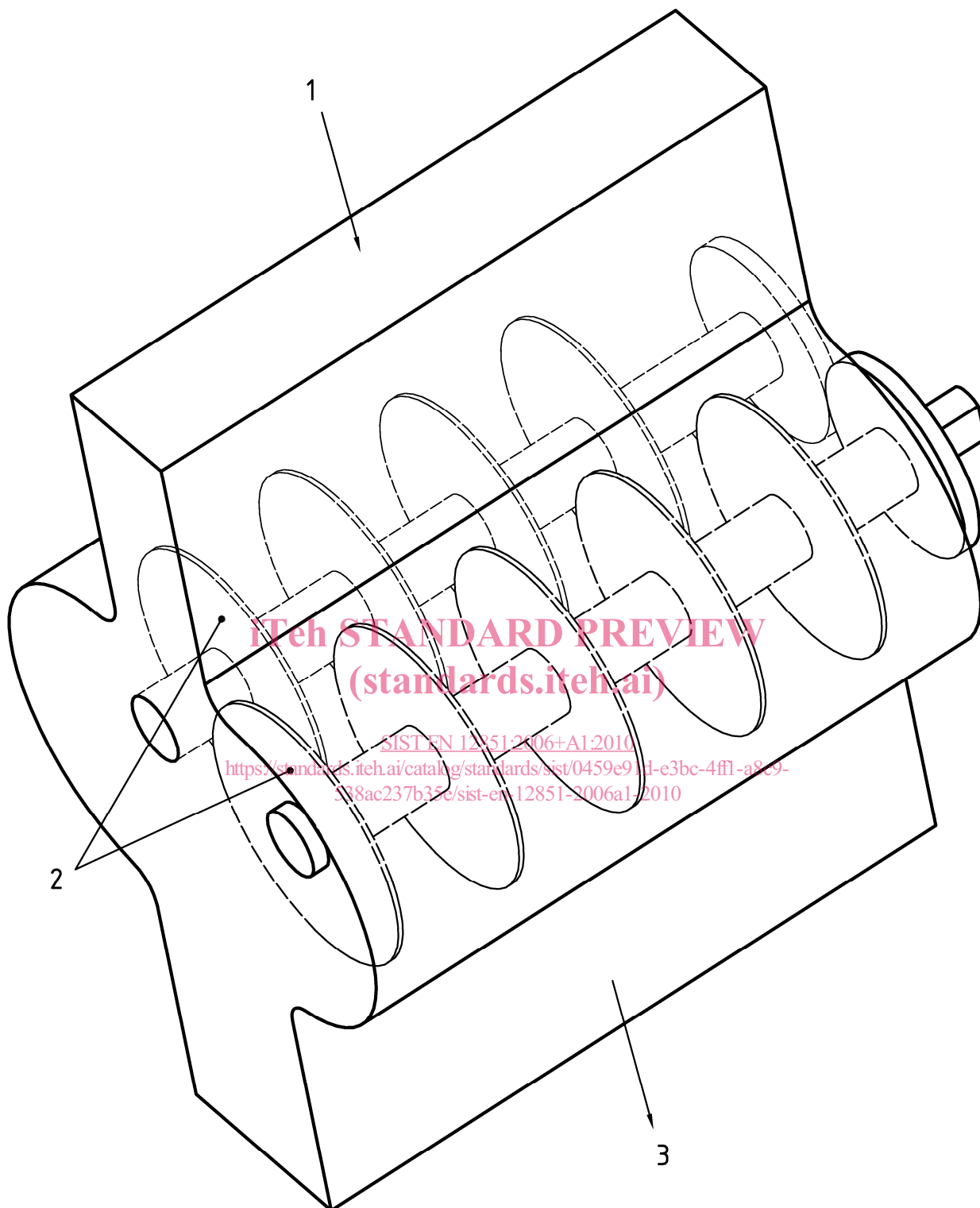
**Key**

- 1 Feed hopper
- 2 Set of circular knives
- 3 Delivery chute

Figure 3 — Description of strip cutter

4) for planetary mixers and whippers (see Figure 4):

— a head (1) supporting tools (2) working with planetary movement in a bowl (3).

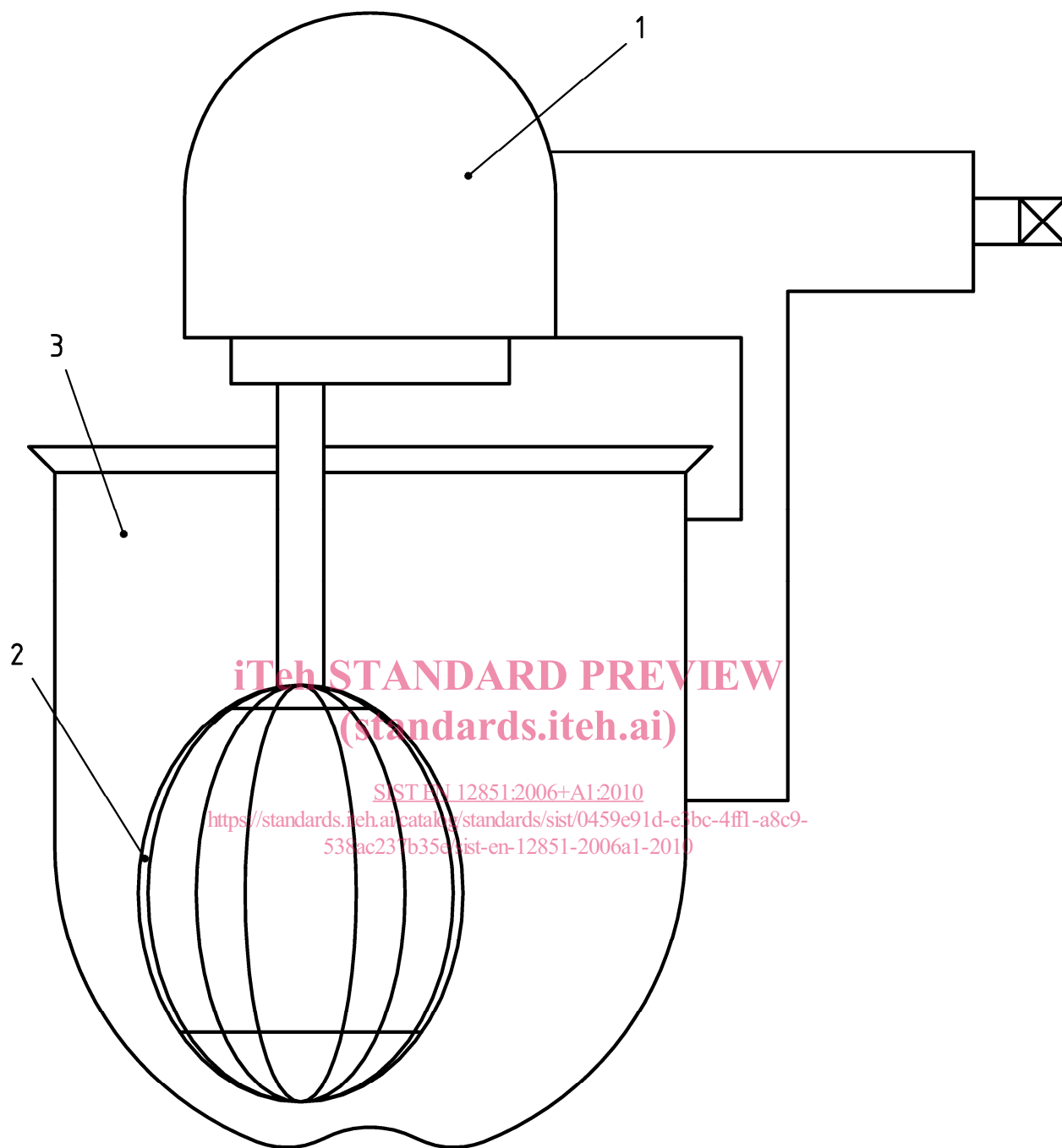
**Key**

- 1 Head
- 2 Tool
- 3 Bowl

Figure 4 — Description of planetary mixers and whippers attachment

5) for potato-mashers (see Figure 5):

- a rotating tool (2) above a fixed grid (3) inside a body (1).