



SLOVENSKI STANDARD
SIST EN 1435:1998/A1:2003
01-maj-2003

**Neporušitvene preiskave zvarnih spojev - Radiografska preiskava zvarnih spojev -
Dopolnilo A1**

Non-destructive testing of welds - Radiographic testing of welded joints

Zerstörungsfreie Prüfung von Schweißverbindungen - Durchstrahlprüfung von
Schmelzscheidungen

Essais non destructifs des assemblages soudés - Contrôle par radiographie des
assemblages soudés

iTeh STANDARD PREVIEW
(standards.iteh.ai)

[SIST EN 1435:1998/A1:2003](https://standards.iteh.ai/catalog/standards/sist/a0e86c34-80bf-40d6-bba8-5c5258600669/sist-en-1435-1998-a1-2003)

Ta slovenski standard je istoveten z: EN 1435:1997/A1:2002

ICS:

25.160.40 Varjeni spoji in vari Welded joints

SIST EN 1435:1998/A1:2003 **en**

iTeh STANDARD PREVIEW
(standards.iteh.ai)

[SIST EN 1435:1998/A1:2003](https://standards.iteh.ai/catalog/standards/sist/a0e86c34-80bf-40d6-bba8-3c5258666869/sist-en-1435-1998-a1-2003)

<https://standards.iteh.ai/catalog/standards/sist/a0e86c34-80bf-40d6-bba8-3c5258666869/sist-en-1435-1998-a1-2003>

EUROPEAN STANDARD
NORME EUROPÉENNE
EUROPÄISCHE NORM

EN 1435:1997/A1

May 2002

ICS 25.160.40

English version

Non-destructive testing of welds - Radiographic testing of welded joints

Contrôle non destructif des assemblages soudés - Contrôle par radiographie des assemblages soudés

Zerstörungsfreie Prüfung von Schweißverbindungen - Durchstrahlungsprüfung von Schmelzschweißungen

This amendment A1 modifies the European Standard EN 1435:1997; it was approved by CEN on 5 May 2002.

CEN members are bound to comply with the CEN/CENELEC Internal Regulations which stipulate the conditions for inclusion of this amendment into the relevant national standard without any alteration. Up-to-date lists and bibliographical references concerning such national standards may be obtained on application to the Management Centre or to any CEN member.

This amendment exists in three official versions (English, French, German). A version in any other language made by translation under the responsibility of a CEN member into its own language and notified to the Management Centre has the same status as the official versions.

CEN members are the national standards bodies of Austria, Belgium, Czech Republic, Denmark, Finland, France, Germany, Greece, Iceland, Ireland, Italy, Luxembourg, Malta, Netherlands, Norway, Portugal, Spain, Sweden, Switzerland and United Kingdom.

STANDARD PREVIEW
(standards.iteh.ai)

<https://standards.iteh.ai/catalog/standards/sist/a0e86c34-80bf-40d6-bba8-3c5258666869/sist-en-1435-1998-a1-2003>



EUROPEAN COMMITTEE FOR STANDARDIZATION
COMITÉ EUROPÉEN DE NORMALISATION
EUROPÄISCHES KOMITEE FÜR NORMUNG

Management Centre: rue de Stassart, 36 B-1050 Brussels

iTeh STANDARD PREVIEW
(standards.iteh.ai)

SIST EN 1435:1998/A1:2003

<https://standards.iteh.ai/catalog/standards/sist/a0e86c34-80bf-40d6-bba8-3c5258666869/sist-en-1435-1998-a1-2003>

iTeh STANDARD PREVIEW
(standards.iteh.ai)

SIST EN 1435:1998/A1:2003

<https://standards.iteh.ai/catalog/standards/sist/a0e86c34-80bf-40d6-bba8-3c5258666869/sist-en-1435-1998-a1-2003>

iTeh STANDARD PREVIEW
(standards.iteh.ai)

SIST EN 1435:1998/A1:2003

<https://standards.iteh.ai/catalog/standards/sist/a0e86c34-80bf-40d6-bba8-3c5258666869/sist-en-1435-1998-a1-2003>

iTeh STANDARD PREVIEW
(standards.iteh.ai)

SIST EN 1435:1998/A1:2003

<https://standards.iteh.ai/catalog/standards/sist/a0e86c34-80bf-40d6-bba8-3c5258666869/sist-en-1435-1998-a1-2003>

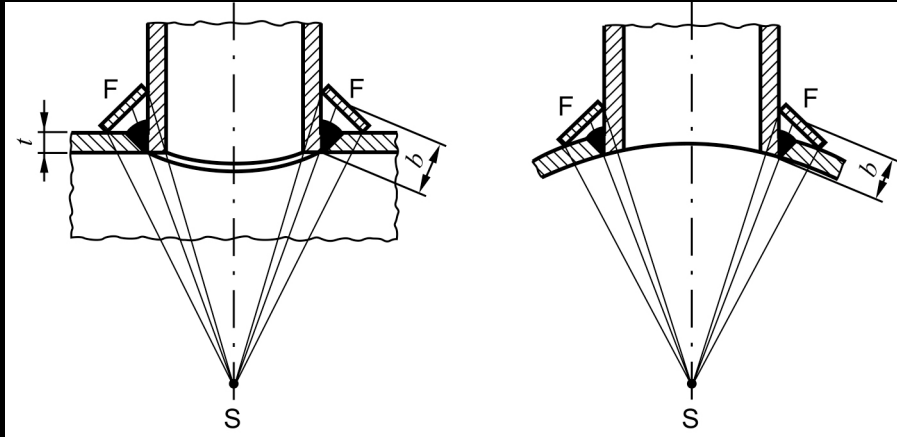

iTeh STANDARD PREVIEW
(standards.iteh.ai)

SIST EN 1435:1998/A1:2003

<https://standards.iteh.ai/catalog/standards/sist/a0e86c34-86bf-40d6-bba8-3c5258666869/sist-en-1435-1998-a1-2003>

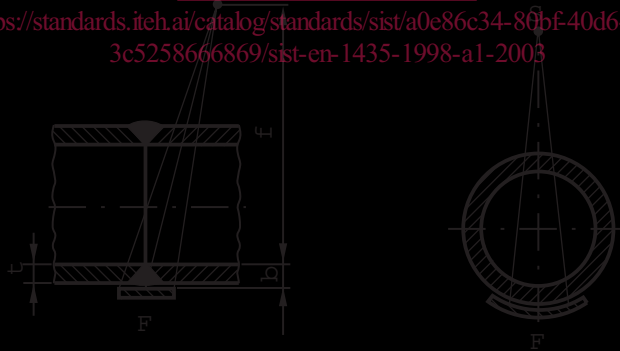

iTeh STANDARD PREVIEW
(standards.iteh.ai)

SIST EN 1435:1998/A1:2003

<https://standards.iteh.ai/catalog/standards/sist/a0e86c34-80bf-40d6-bba8-3c5258666869/sist-en-1435-1998-a1-2003>