

SLOVENSKI STANDARD

SIST EN 2997-009:2010

01-september-2010

Nadomešča:

SIST EN 2997-009:2009

Aeronavtika - Konektorji, električni, okrogli, priključeni z navojnim obročkom, odporni ali neodporni proti ognju, s stalno delovno temperaturo med –65 °C in 175 °C, stalno 200 °C, najvišjo 260 °C - 009. del: Zaščitna kapa - Standard za proizvod

Aerospace series - Connectors, electrical, circular, coupled by threaded ring, fire-resistant or non fire-resistant, operating temperatures - 65 °C to 175 °C continuous, 200 °C continuous, 260 °C peak - Part 009: Protective cover for receptacle - Product standard

(standards.iteh.ai)

Luft- und Raumfahrt - Elektrische Rundsteckverbinder mit Schraubkupplung, feuerbeständig oder nicht feuerbeständig, Betriebstemperaturen - 65 °C bis 175 °C konstant, 200 °C konstant, 260 °C Spitze - Teil 009: Schutzkappe für festen Steckverbinder - Produktnorm

Série aérospatiale - Connecteurs électriques circulaires à accouplement par bague filetée, résistant au feu ou non, températures d'utilisation - 65 °C à 175 °C continu, 200 °C continu, 260 °C en pointe - Partie 009 : Bouchon de vol pour embase - Norme de produit

Ta slovenski standard je istoveten z: EN 2997-009:2010

ICS:

49.060	Letalska in vesoljska električna oprema in sistemi	Aerospace electric equipment and systems
--------	--	--

SIST EN 2997-009:2010

en

iTeh STANDARD PREVIEW
(standards.iteh.ai)

SIST EN 2997-009:2010

<https://standards.iteh.ai/catalog/standards/sist/e2fb64cd-9411-4350-abef-b4c744301cdc/sist-en-2997-009-2010>

EUROPEAN STANDARD

EN 2997-009

NORME EUROPÉENNE

EUROPÄISCHE NORM

June 2010

ICS 49.060

Supersedes EN 2997-009:2006

English Version

Aerospace series - Connectors, electrical, circular, coupled by threaded ring, fire-resistant or non fire-resistant, operating temperatures - 65 °C to 175 °C continuous, 200 °C continuous, 260 °C peak - Part 009: Protective cover for receptacle - Product standard

Série aérospatiale - Connecteurs électriques circulaires à accouplement par bague fileté, résistant au feu ou non, températures d'utilisation - 65 °C à 175 °C continu, 200 °C continu, 260 °C en pointe - Partie 009 : Bouchon de vol pour embase - Norme de produit

Luft- und Raumfahrt - Elektrische Rundsteckverbinder mit Schraubkupplung, feuerbeständig oder nicht feuerbeständig, Betriebstemperaturen - 65 °C bis 175 °C konstant, 200 °C konstant, 260 °C Spitze - Teil 009: Schutzkappe für festen Steckverbinder - Produktnorm

This European Standard was approved by CEN on 19 May 2010.

CEN members are bound to comply with the CEN/CENELEC Internal Regulations which stipulate the conditions for giving this European Standard the status of a national standard without any alteration. Up-to-date lists and bibliographical references concerning such national standards may be obtained on application to the CEN Management Centre or to any CEN member.

This European Standard exists in three official versions (English, French, German). A version in any other language made by translation under the responsibility of a CEN member into its own language and notified to the CEN Management Centre has the same status as the official versions.

CEN members are the national standards bodies of Austria, Belgium, Bulgaria, Croatia, Cyprus, Czech Republic, Denmark, Estonia, Finland, France, Germany, Greece, Hungary, Iceland, Ireland, Italy, Latvia, Lithuania, Luxembourg, Malta, Netherlands, Norway, Poland, Portugal, Romania, Slovakia, Slovenia, Spain, Sweden, Switzerland and United Kingdom.



EUROPEAN COMMITTEE FOR STANDARDIZATION
COMITÉ EUROPÉEN DE NORMALISATION
EUROPÄISCHES KOMITEE FÜR NORMUNG

Management Centre: Avenue Marnix 17, B-1000 Brussels

Contents

Page

Foreword.....	3
1 Scope	4
2 Normative references	4
3 Terms and definitions	4
4 Required characteristics	5
5 Designation	7
6 Marking	7
7 Technical specification	7

iTeh STANDARD PREVIEW
(standards.iteh.ai)

[SIST EN 2997-009:2010](https://standards.iteh.ai/catalog/standards/sist/e2fb64cd-9411-4350-abef-b4c744301cdc/sist-en-2997-009-2010)

<https://standards.iteh.ai/catalog/standards/sist/e2fb64cd-9411-4350-abef-b4c744301cdc/sist-en-2997-009-2010>

Foreword

This document (EN 2997-009:2010) has been prepared by the Aerospace and Defence Industries Association of Europe - Standardization (ASD-STAN).

After enquiries and votes carried out in accordance with the rules of this Association, this Standard has received the approval of the National Associations and the Official Services of the member countries of ASD, prior to its presentation to CEN.

This European Standard shall be given the status of a national standard, either by publication of an identical text or by endorsement, at the latest by December 2010, and conflicting national standards shall be withdrawn at the latest by December 2010.

Attention is drawn to the possibility that some of the elements of this document may be the subject of patent rights. CEN [and/or CENELEC] shall not be held responsible for identifying any or all such patent rights.

This document supersedes EN 2997-009:2006.

According to the CEN/CENELEC Internal Regulations, the national standards organizations of the following countries are bound to implement this European Standard: Austria, Belgium, Bulgaria, Croatia, Cyprus, Czech Republic, Denmark, Estonia, Finland, France, Germany, Greece, Hungary, Iceland, Ireland, Italy, Latvia, Lithuania, Luxembourg, Malta, Netherlands, Norway, Poland, Portugal, Romania, Slovakia, Slovenia, Spain, Sweden, Switzerland and the United Kingdom.

SIST EN 2997-009:2010

<https://standards.iteh.ai/catalog/standards/sist/e2fb64cd-9411-4350-abef-b4c744301cdc/sist-en-2997-009-2010>

EN 2997-009:2010 (E)

1 Scope

This European Standard specifies the characteristics of protective covers for receptacles in the family of circular electrical connectors coupled by threaded ring.

It applies to the class defined in Table 2.

For receptacles associated with these protective covers, see EN 2997-003 to EN 2997-007.

2 Normative references

The following referenced documents are indispensable for the application of this document. For dated references, only the edition cited applies. For undated references, the latest edition of the referenced document (including any amendments) applies.

EN 2997-001:2006, *Aerospace series — Connectors, electrical, circular, coupled by threaded ring, fire-resistant or non fire-resistant, operating temperatures – 65 °C to 175 °C continuous, 200 °C continuous, 260 °C peak — Part 001: Technical specification*

EN 2997-002, *Aerospace series — Connectors, electrical, circular, coupled by threaded ring, fire-resistant or non fire-resistant, operating temperatures – 65 °C to 175 °C continuous, 200 °C continuous, 260 °C peak — Part 002: Specification of performance and contact arrangements*

EN 2997-003, *Aerospace series — Connectors, electrical, circular, coupled by threaded ring, fire-resistant or non fire-resistant, operating temperatures – 65 °C to 175 °C continuous, 200 °C continuous, 260 °C peak — Part 003: Square flange receptacle — Product standard*

EN 2997-004, *Aerospace series — Connectors, electrical, circular, coupled by threaded ring, fire-resistant or non fire-resistant, operating temperatures – 65 °C to 175 °C continuous, 200 °C continuous, 260 °C peak — Part 004: Jam-nut mounted receptacle — Product standard*

EN 2997-005, *Aerospace series — Connectors, electrical, circular, coupled by threaded ring, fire-resistant or non fire-resistant, operating temperatures – 65 °C to 175 °C continuous, 200 °C continuous, 260 °C peak — Part 005: Hermetic square flange receptacle — Product standard*

EN 2997-006, *Aerospace series — Connectors, electrical, circular, coupled by threaded ring, fire-resistant or non fire-resistant, operating temperatures – 65 °C to 175 °C continuous, 200 °C continuous, 260 °C peak — Part 006: Hermetic jam-nut mounted receptacle — Product standard*

EN 2997-007, *Aerospace series — Connectors, electrical, circular, coupled by threaded ring, fire-resistant or non fire-resistant, operating temperatures – 65 °C to 175 °C continuous, 200 °C continuous, 260 °C peak — Part 007: Hermetic receptacle with round flange attached by welding or brazing — Product standard*

ISO 263, *ISO inch screw threads — General plan and selection for screws, bolts and nuts — Diameter range 0,06 to 6 in*

3 Terms and definitions

For the purposes of this standard, the terms and definitions given in EN 2997-001:2006 apply.

4 Required characteristics

4.1 Dimensions and mass

See Figure 1 and Table 1.

Dimensions and tolerances are in millimetres; they apply after surface treatment.

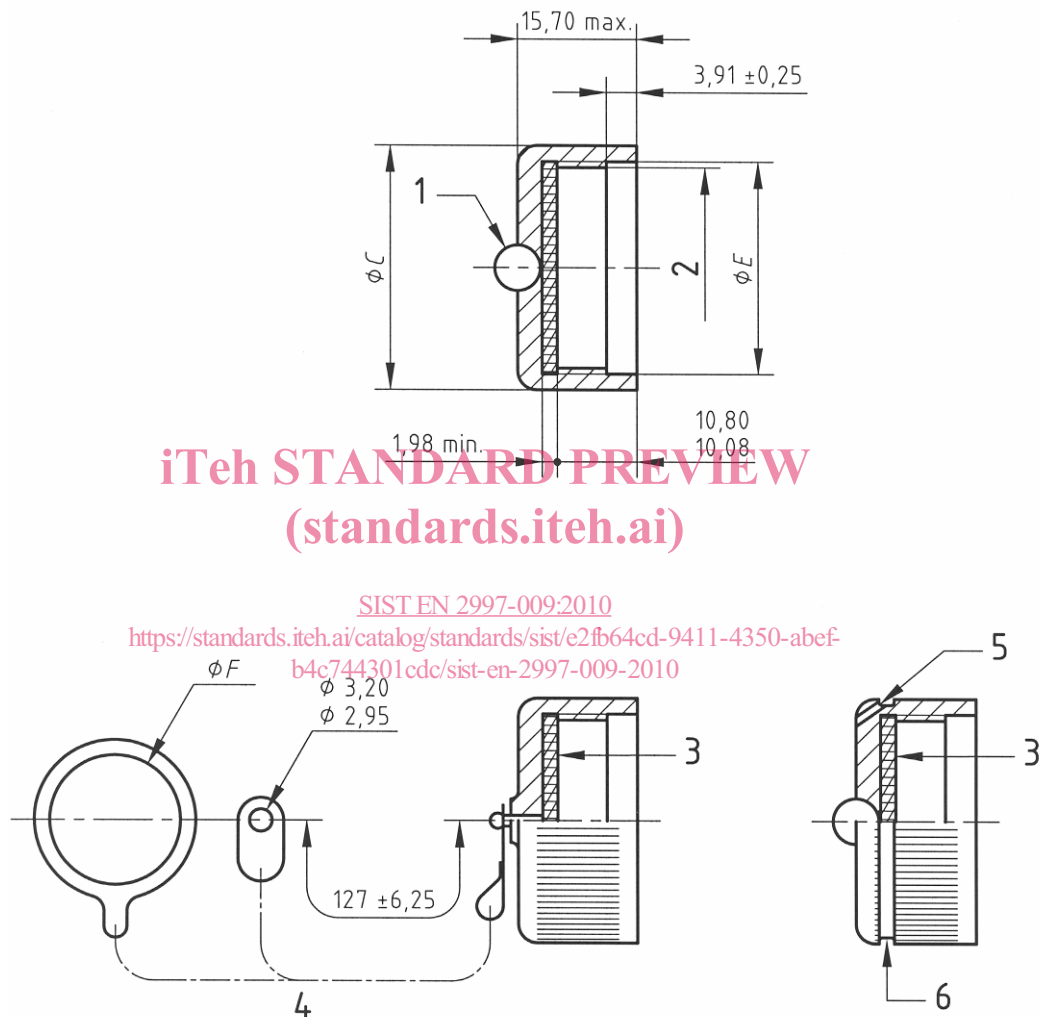

Key

- 1 Attachment of chain or cord
- 2 Thread
- 3 Seal
- 4 Chain or cord
- 5 Three holes $\varnothing 0,95$ min. at 120°
- 6 Optional groove

Figure 1

Table 1

Housing size	Thread class 2B ^a	Ø C max.	Ø E Minimum bore	Ø F ± 0,38 Eyelet inner	Mass g max.	
					Stainless steel	Aluminium alloy
08	0,5625-24UNEF	19,71	14,61	16,30	26,2	9,5
10	0,6875-24UNEF	23,01	17,96	19,50	33,6	12,1
12	0,8750-20UNEF	27,38	22,73	24,60	43,5	15,6
14	0,9375-20UNEF	28,98	24,31	25,80	47,8	17,1
16	1,0625-18UNEF	32,16	27,53	29,00	56,8	20,4
18	1,1875-18UNEF	34,93	30,71	32,20	62,9	22,6
20	1,3125-18UNEF	38,35	33,88	35,30	75,5	27,1
22	1,4375-18UNEF	41,29	37,06	38,60	84,0	30,1
24	1,5625-18UNEF	44,70	40,23	41,70	97,7	35,1
28	1,8125-16UNS	51,00	46,58	48,00	120,2	43,1

^a ISO 263.

iTech STANDARD PREVIEW

4.2 Material, surface treatment (standards.iteh.ai)

See Table 2.

[SIST EN 2997-009:2010](https://standards.iteh.ai/catalog/standards/sist/e2fb64cd-9411-4350-abef-b4c744301cdc/sist-en-2997-009-2010)

[https://standards.iteh.ai/catalog/standards/sist/e2fb64cd-9411-4350-abef-](https://standards.iteh.ai/catalog/standards/sist/e2fb64cd-9411-4350-abef-b4c744301cdc/sist-en-2997-009-2010)

4.3 Main general characteristics [b4c744301cdc/sist-en-2997-009-2010](https://standards.iteh.ai/catalog/standards/sist/e2fb64cd-9411-4350-abef-b4c744301cdc/sist-en-2997-009-2010)

See EN 2997-002.

4.4 Possible combinations of protective covers and connectors

See EN 2997-002.