



Designation: F 2098 – 04

Standard Specification for Stainless Steel Clamps for Securing SDR9 Cross-linked Polyethylene (PEX) Tubing to Metal Insert Fittings¹²

This standard is issued under the fixed designation F 2098; the number immediately following the designation indicates the year of original adoption or, in the case of revision, the year of last revision. A number in parentheses indicates the year of last reapproval. A superscript epsilon (ϵ) indicates an editorial change since the last revision or reapproval.

1. Scope

1.1 This specification covers stainless steel clamps for use with four sizes of insert fittings that comply with F 1807, and cross-linked polyethylene (PEX) plastic tubing that complies with F 876 or F 877. These clamps are intended as an alternative to the copper-alloy crimp-rings of Specifications F 1807 or F 2159 for use in 100 psi (689.5 kPa) cold- and hot-water distribution systems operating at temperatures up to and including 180°F (82°C). Included are requirements for materials, workmanship, dimensions and marking of the stainless steel clamps; requirements for deforming the clamps; which apply to assemblies of PEX tubing and Specifications F 1807 and F 2159, insert fittings secured with deformed clamps per this specification.

1.2 The values stated in inch-pound units are to be regarded as the standard. The SI values stated in parentheses are provided for information purposes.

1.3 *This standard does not purport to address all of the safety concerns, if any, associated with its use. It is the responsibility of the user of this standard to establish appropriate safety and health practices and determine the applicability of regulatory limitations prior to use.*

2. Referenced Documents

2.1 ASTM Standards:³

A 240 Specification for Heat-Resisting Chromium and Chromium-Nickel Stainless Steel Plate, Sheet, and Strip for Pressure Vessels

D 618 Practice for Conditioning Plastics and Electrical Insulating Materials for Testing

D 1598 Test Method for Time-To-Failure of Plastic Pipe Under Constant Internal Pressure

D 1599 Test Method for Short-Time, Hydraulic Failure Pressure of Plastic Pipe, Tubing, and Fittings

D 1600 Terminology for Abbreviated Terms Relating to Plastics

D 2122 Test Method for Determining Dimensions of Thermoplastic Pipe and Fittings

E 18 Test Methods for Rockwell Hardness and Superficial Hardness of Metallic Materials

F 412 Terminology Relating to Plastic Piping Systems

F 876 Specification for Cross-linked Polyethylene (PEX) Tubing

F 877 Specification for Cross-linked Polyethylene (PEX) Plastic Hot- and Cold-Water Distribution Systems

F 1807 Specification for Metal Insert Fittings Utilizing a Copper Crimp Ring for SDR9 Cross-linked Polyethylene (PEX) Tubing

F 2159 Specification for Plastic insert Fitting Utilizing a Copper Crimp Ring for SDR9 Cross-linked Polyethylene (PEX) Tubing.

3. Terminology

3.1 Definitions are in accordance with Terminology F 412 and abbreviations are in accordance with Terminology D 1600, unless otherwise indicated.

4. Classification

4.1 This specification covers one class of stainless steel clamps in four sizes suitable for securing PEX tubing that meets the requirements of Specifications F 876 or F 877 to insert fittings that meet the requirements of Specifications F 1807 and F 2159.

5. Materials and Manufacture

5.1 *Clamps*—Clamps shall be made from material meeting the requirements of Specification A 240 stainless steel UNS S304000.

6. General Requirements

6.1 The following sections of Specification F 877 constitute a part of this specification.

6.1.1 Requirements,

6.1.2 Test Methods, and

¹ This specification is under the jurisdiction of ASTM Committee F17 on Plastic Piping Systems and is the direct responsibility of Subcommittee F17.10 on Fittings.

Current edition approved April 1, 2004. Published June 2004. Originally approved 2001. Last previous edition approved in 2001 as F2098-01

² The stainless steel clamp described in this standard is covered by a patent. Interested parties are invited to submit information regarding the identification of an alternative to this patented item to ASTM Headquarters. Your comments will receive careful consideration at a meeting of F17, which you may attend.

³ For referenced ASTM standards, visit the ASTM website, www.astm.org, or contact ASTM Customer Service at service@astm.org. For *Annual Book of ASTM Standards* volume information, refer to the standard's Document Summary page on the ASTM website.

6.1.3 Retest and Rejection.

6.2 In addition, when a section with a title identical to that referenced in 6.1 above, appears in this specification, it contains additional requirements that supplement those appearing in Specification F 877.

6.3 *General*—All performance tests shall be performed on assemblies of fittings, clamps and PEX tubing. Clamps shall meet the material and dimensional requirements of this specification. Fittings shall meet the material and dimensional requirements of F 1807. PEX tubing shall meet the requirements of Specification F 876 or F 877. Assembly of test specimens shall be in accordance with 9.1.1. Each assembly shall contain at least two (2) joints. Use separate sets of assemblies for each performance test requirement.

7. Dimensions

7.1 *Dimensions and Tolerances*—The dimensions and tolerances of clamps shall be as shown in Figs. 1-4.

8. Workmanship, Finish and Appearance

8.1 The surfaces of the clamps shall be smooth and free of foreign material. Clamps shall be free of cracks, holes, corrosion, voids, foreign inclusions, or other defects that are visible to the unaided eye that have potential to affect the clamp integrity.

9. Assembly

9.1 *Clamp Joints*—Insert fittings shall be joined to PEX tubing by deforming and locking a stainless steel clamp around

the outer circumference of the tubing, forcing the tubing material into annular spaces formed by the ribs on the fitting. Insert fittings shall meet the dimensional and material requirements of F 1807. PEX tubing shall meet the requirements of Specifications F 876 or F 877. Clamps shall meet the dimensional and material requirements of this specification.

9.1.1 *Clamping Procedure*—The clamping procedure shall be as follows: slide the clamp onto the tubing, insert the ribbed end of the fitting into the end of the tubing until the tubing contacts the shoulder of the fitting or tube stop. The clamp shall then be positioned on the tubing so the edge of the clamp is 1/8 to 1/4 in. (3.2 to 6.4 mm) from the end of the tube. The ratcheting clamping tool shall be used to close the clamp. The tool will not release until the clamp is properly closed. Ratcheting hand tools shall conform to the dimensional requirements of Fig. 5.

10. Retest

10.1 If any failure occurs, a retest shall be conducted only if agreed upon between the purchaser and the seller. Failure in the retest indicates the quantity of clamps represented by the sample does not conform to the requirements of this specification.

11. Product Marking

11.1 *Quality of Marking*—The marking shall be applied to the clamps in such a manner that it remains legible after installation and inspection.

11.2 *Content of Marking*:

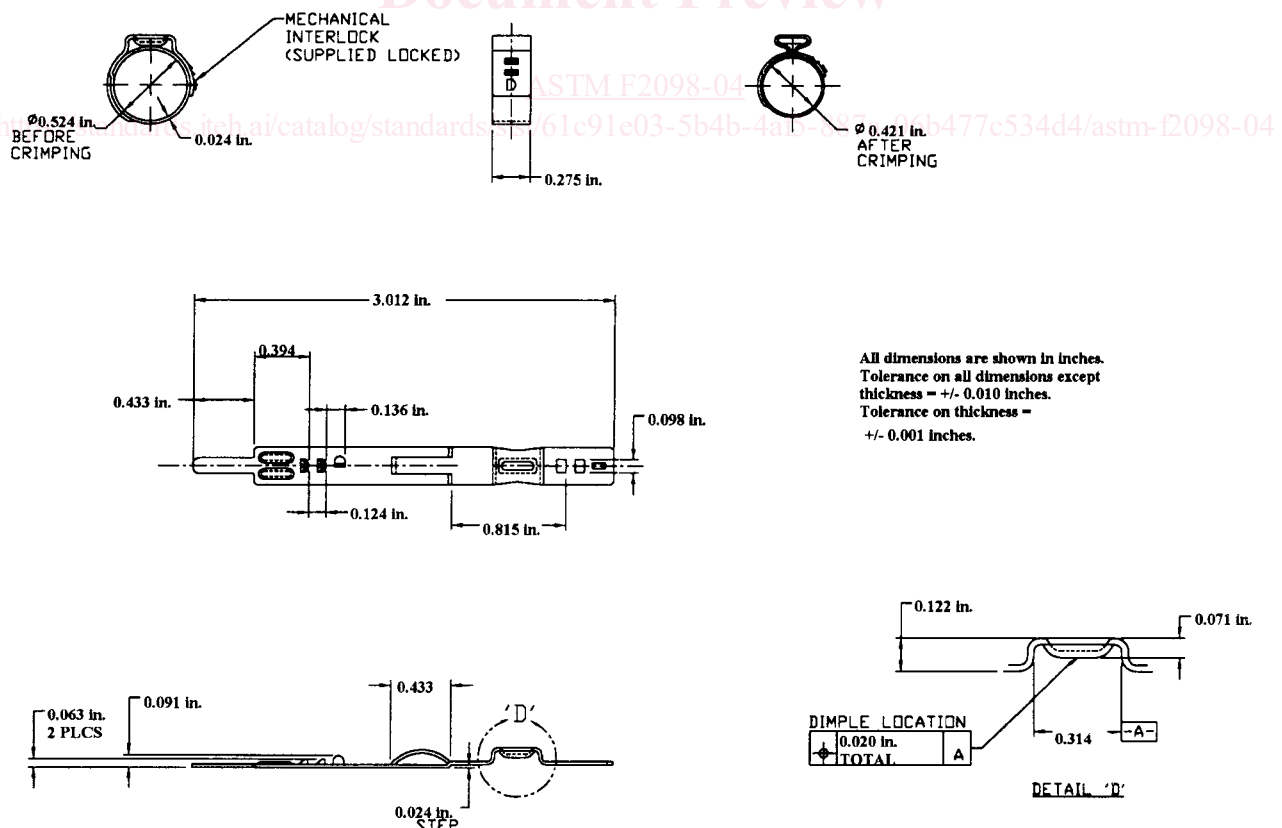

FIG. 1 Stainless Steel Clamp Dimensions, 3/8-in. nominal