**Plastics and ebonite — Determination of
indentation hardness by means of a
durometer (Shore hardness)**

*Plastiques et ébonite — Détermination de la dureté par pénétration au
moyen d'un duromètre (dureté Shore)*

iTeh Standards
(<https://standards.iteh.ai>)
Document Preview

[ISO 868:2003](https://standards.iteh.ai/catalog/standards/iso/b00a2780-f641-4857-8bb1-eb0d574b4af3/iso-868-2003)

<https://standards.iteh.ai/catalog/standards/iso/b00a2780-f641-4857-8bb1-eb0d574b4af3/iso-868-2003>



PDF disclaimer

This PDF file may contain embedded typefaces. In accordance with Adobe's licensing policy, this file may be printed or viewed but shall not be edited unless the typefaces which are embedded are licensed to and installed on the computer performing the editing. In downloading this file, parties accept therein the responsibility of not infringing Adobe's licensing policy. The ISO Central Secretariat accepts no liability in this area.

Adobe is a trademark of Adobe Systems Incorporated.

Details of the software products used to create this PDF file can be found in the General Info relative to the file; the PDF-creation parameters were optimized for printing. Every care has been taken to ensure that the file is suitable for use by ISO member bodies. In the unlikely event that a problem relating to it is found, please inform the Central Secretariat at the address given below.

iTeh Standards
(<https://standards.itih.ai>)
Document Preview

ISO 868:2003

<https://standards.itih.ai/catalog/standards/iso/b00a2780-f641-4857-8bb1-eb0d574b4af3/iso-868-2003>

© ISO 2003

All rights reserved. Unless otherwise specified, no part of this publication may be reproduced or utilized in any form or by any means, electronic or mechanical, including photocopying and microfilm, without permission in writing from either ISO at the address below or ISO's member body in the country of the requester.

ISO copyright office
Case postale 56 • CH-1211 Geneva 20
Tel. + 41 22 749 01 11
Fax + 41 22 749 09 47
E-mail copyright@iso.ch
Web www.iso.ch

Printed in Switzerland

Contents

	Page
1 Scope	1
2 Normative reference	1
3 Principle	1
4 Apparatus	1
5 Test specimens	4
6 Calibration	4
7 Conditioning and testing atmospheres	4
8 Procedure	5
9 Test report	5

iTeh Standards
(<https://standards.itih.ai>)
Document Preview

[ISO 868:2003](https://standards.itih.ai/catalog/standards/iso/b00a2780-f641-4857-8bb1-eb0d574b4af3/iso-868-2003)

<https://standards.itih.ai/catalog/standards/iso/b00a2780-f641-4857-8bb1-eb0d574b4af3/iso-868-2003>

Foreword

ISO (the International Organization for Standardization) is a worldwide federation of national standards bodies (ISO member bodies). The work of preparing International Standards is normally carried out through ISO technical committees. Each member body interested in a subject for which a technical committee has been established has the right to be represented on that committee. International organizations, governmental and non-governmental, in liaison with ISO, also take part in the work. ISO collaborates closely with the International Electrotechnical Commission (IEC) on all matters of electrotechnical standardization.

International Standards are drafted in accordance with the rules given in the ISO/IEC Directives, Part 3.

Draft International Standards adopted by the technical committees are circulated to the member bodies for voting. Publication as an International Standard requires approval by at least 75 % of the member bodies casting a vote.

Attention is drawn to the possibility that some of the elements of this International Standard may be the subject of patent rights. ISO shall not be held responsible for identifying any or all such patent rights.

International Standard ISO 868 was prepared by Technical Committee ISO/TC 61, *Plastics*, Subcommittee SC 2, *Mechanical properties*.

This third edition cancels and replaces the second edition (ISO 868:1985), which has been technically revised.

iteh Standards
(<https://standards.iteh.ai>)
Document Preview

[ISO 868:2003](https://standards.iteh.ai/catalog/standards/iso/b00a2780-f641-4857-8bb1-eb0d574b4af3/iso-868-2003)

<https://standards.iteh.ai/catalog/standards/iso/b00a2780-f641-4857-8bb1-eb0d574b4af3/iso-868-2003>

Plastics and ebonite — Determination of indentation hardness by means of a durometer (Shore hardness)

1 Scope

1.1 This International Standard specifies a method for the determination of the indentation hardness of plastics and ebonite by means of durometers of two types: type A is used for softer materials and type D for harder materials (see the Note to 8.2). The method permits measurement either of the initial indentation or of the indentation after a specified period of time, or both.

NOTE The durometers and the methods specified in this International Standard are referred to as type A Shore and type D Shore durometers and durometer methods, respectively.

1.2 This method is an empirical method intended primarily for control purposes. No simple relationship exists between indentation hardness determined by this method and any fundamental property of the material tested. For specification purposes, it is recommended that ISO 48, *Rubber, vulcanized or thermoplastic — Determination of hardness (hardness between 10 IRHD and 100 IRHD)*, be used for the softer materials.

2 Normative reference

The following normative document contains provisions which, through reference in this text, constitute provisions of this International Standard. For dated references, subsequent amendments to, or revisions of, this publication do not apply. However, parties to agreements based on this International Standard are encouraged to investigate the possibility of applying the most recent edition of the normative document indicated below. For undated references, the latest edition of the normative document referred to applies. Members of ISO and IEC maintain registers of currently valid International Standards.

ISO 291:1997, *Plastics — Standard atmospheres for conditioning and testing*

3 Principle

A specified indenter is forced into the test material under specified conditions and the depth of penetration measured.

The indentation hardness is inversely related to the penetration and is dependent on the modulus of elasticity and the viscoelastic properties of the material. The shape of the indenter, the force applied to it and the duration of its application influence the results obtained so that there may be no simple relationship between the results obtained with one type of durometer and those obtained with either another type of durometer or another instrument for measuring hardness.

4 Apparatus

Use either a type A or type D Shore durometer consisting of the following components:

4.1 Presser foot, with a hole of diameter $3 \text{ mm} \pm 0,5 \text{ mm}$ centred at least 6 mm from any edge of the foot.

4.2 Indenter, formed from a hardened steel rod of diameter $1,25 \text{ mm} \pm 0,15 \text{ mm}$ to the shape and dimensions shown in Figure 1 for type A durometers and Figure 2 for type D durometers.

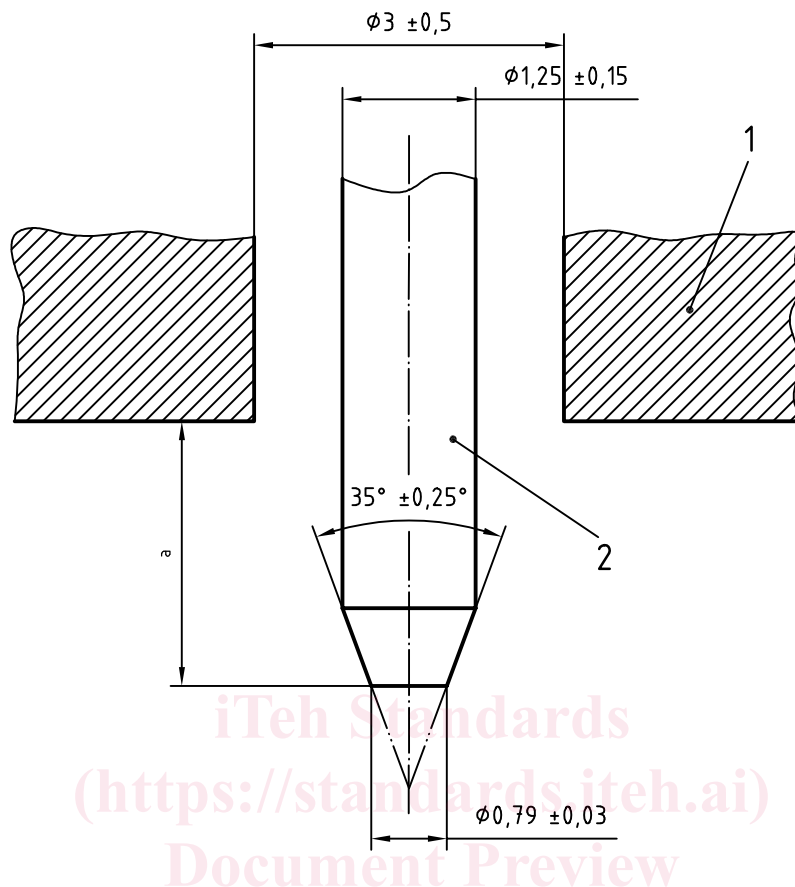

Key

- 1 presser foot
- 2 indenter

^a full protrusion: 2,5 mm ± 0,04 mm

Figure 1 — Indenter for type A durometer

4.3 Indicating device, for reading the extent of protrusion of the point of the indenter beyond the face of the presser foot; this may be read directly in terms of units ranging from 0 for the full protrusion of 2,50 mm ± 0,04 mm to 100 for nil protrusion obtained by placing the pressure foot and indenter in firm contact with a flat piece of glass.

NOTE The device may include means for indicating the initial indentation obtained when the indenter is applied under load, to provide a maximum reading for use as an instantaneous reading if required (see 8.1).