



Designation: D 3174 – 02^{ε1}

Standard Test Method for Ash in the Analysis Sample of Coal and Coke from Coal¹

This standard is issued under the fixed designation D 3174; the number immediately following the designation indicates the year of original adoption or, in the case of revision, the year of last revision. A number in parentheses indicates the year of last reappraisal. A superscript epsilon (ϵ) indicates an editorial change since the last revision or reappraisal.

^{ε1} NOTE—Table 2 and sections 10.1.2, 10.1.2.1 and 10.1.2.2 were editorially corrected in June 2004.

1. Scope

1.1 This test method covers the determination of the inorganic residue as ash in the analysis sample of coal or coke as prepared in accordance with Method D 2013 or Practice D 346. The results obtained can be applied as the ash in the proximate analysis, Practice D 3172, and in the ultimate analysis, Practice D 3176. For the determination of the constituents in ash, reference is made to Test Methods D 2795 and D 3682. See Terminology D 121 for definition of ash.

1.2 The values stated in SI units are to be regarded as the standard.

1.3 *This standard does not purport to address all of the safety concerns, if any, associated with its use. It is the responsibility of the user of this standard to establish appropriate safety and health practices and determine the applicability of regulatory limitations prior to use.*

2. Referenced Documents

2.1 ASTM Standards:²

- D 121 Terminology of Coal and Coke
- D 346 Practice for Collection and Preparation of Coke Samples for Laboratory Analysis
- D 388 Classification of Coals by Rank
- D 1756 Test Method for Determination as Carbon Dioxide of Carbonate Carbon in Coal
- D 1757 Test Method for Sulfate Sulfur in Ash from Coal and Coke
- D 2013 Method of Preparing Coal Samples for Analysis
- D 2795 Test Methods for Analysis of Coal and Coke Ash
- D 3172 Practice for Proximate Analysis of Coal and Coke
- D 3173 Test Method for Moisture in the Analysis Sample of Coal and Coke

¹ This test method is under the jurisdiction of ASTM Committee D05 on Coal and Coke and is the direct responsibility of Subcommittee D05.21 on Methods of Analysis.

Current edition approved September 10, 2002. Published October 2002. Originally published as D 3174 – 73. Last previous edition D 3174 – 00.

² For referenced ASTM standards, visit the ASTM website, www.astm.org, or contact ASTM Customer Service at service@astm.org. For *Annual Book of ASTM Standards* volume information, refer to the standard's Document Summary page on the ASTM website.

- D 3176 Practice for Ultimate Analysis of Coal and Coke
- D 3180 Practice for Calculating Coal and Coke Analyses from As-Determined to Different Bases
- D 3682 Test Method for Major and Minor Elements in Coal and Coke Ash by the Atomic Absorption Method
- E 691 Practice for Conducting an Interlaboratory Study to Determine the Precision of a Test Method

3. Summary of Test Method

3.1 Ash is determined by weighing the residue remaining after burning the coal or coke under rigidly controlled conditions of sample weight, temperature, time, atmosphere, and equipment specifications.

4. Significance and Use

4.1 Ash, as determined by this test method, is the residue remaining after burning the coal and coke. Ash obtained differs in composition from the inorganic constituents present in the original coal. Incineration causes an expulsion of all water, the loss of carbon dioxide from carbonates, the conversion of iron pyrites into ferric oxide, and other chemical reactions. Ash, as determined by this test method, will differ in amount from ash produced in furnace operations and other firing systems because incineration conditions influence the chemistry and amount of the ash. References for correcting ash results determined by this test method to a mineral-matter-free basis are listed in Classification D 388, Section 8.

5. Apparatus

5.1 *Electric Muffle Furnace for Coal or Coke*—For determination of ash of coal, the furnace shall have an adequate air circulation and be capable of having its temperature regulated at 700 to 750°C. The furnace shall be equipped with a temperature indicator and means of controlling the temperature within prescribed limits. Means shall be provided for maintaining air flow at a rate of two to four changes per minute (see Fig. 1 and Fig. 2). Combustion gases shall be vented from laboratory. Inlet and outlet ports shall be located and arranged to distribute the air uniformly throughout the furnace area without the possibility of sweeping solid particles from the

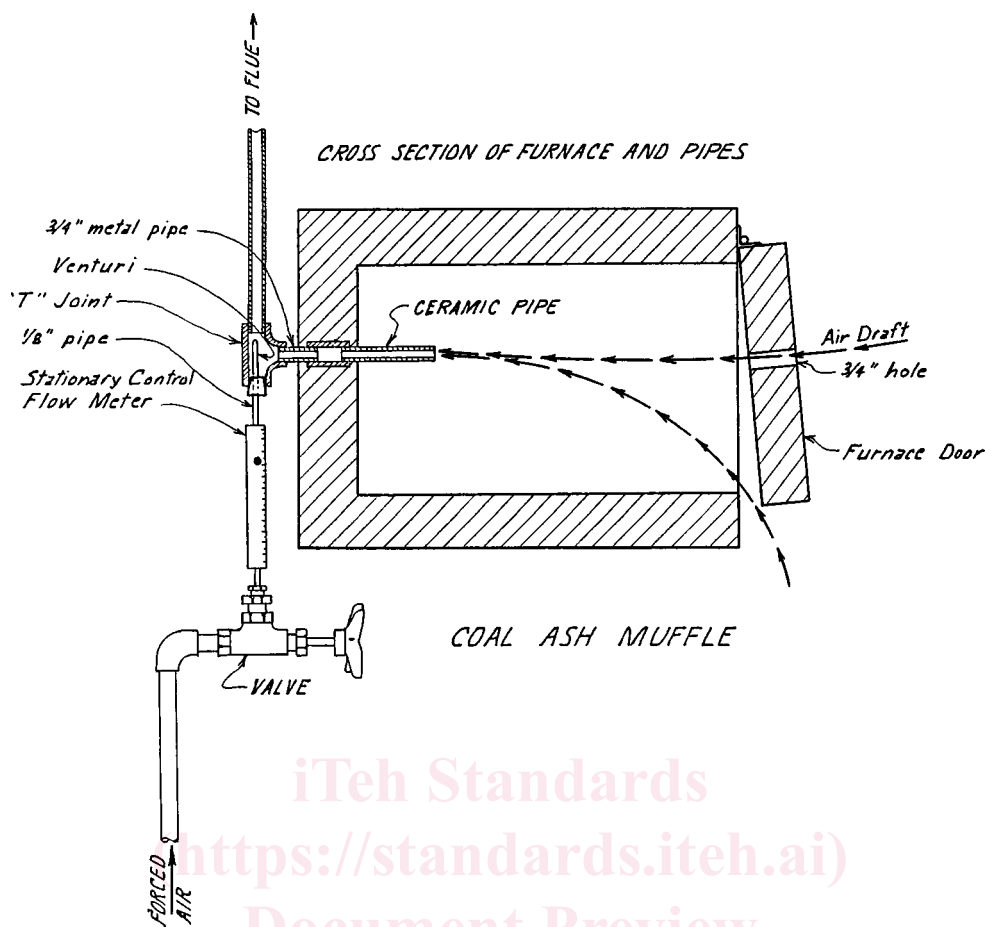

(Suggested method for inducing regulated air flow through ashing furnace.)

FIG. 1 Air Aspirator

iTeh Standards
<https://standards.itih.ai>
 Document Preview

ASTM D3174-02e1

capsules. The temperature over the entire working area of the furnace floor shall be maintained within the specified temperature limits.

5.2 *Porcelain Capsules*, about 22 mm (7/8 in.) in depth, and 44 mm (1 3/4 in.) in diameter, or similar shallow dishes or platinum crucibles.

5.3 *Balance*, sensitive to 0.1 mg.

5.4 *Crucible Cover*, aluminum, porcelain, or similar covers.

6. Temperature Calibration

6.1 Place a preignited capsule with 1 g of sand at the center of the working area of the furnace, and by the use of a potentiometer and thermocouple or other suitable temperature measuring device, measure the temperature of the sand in the crucible. The crucible and sand should be at temperature equilibrium with the furnace. There should be two to four air changes per minute moving throughout the furnace (the air flow may be measured by using a wet-test meter or equivalent calibrated at standard conditions for air connected to the ceramic-pipe exhaust). Adjust the furnace temperature until the potentiometer reads $750 \pm 10^\circ\text{C}$ and then adjust or read the temperature on the indicating pyrometer. Use this reading as the proper setting for controlling the furnace.

7. Procedure

7.1 The sample shall be the material pulverized to pass No. 60 (250- μm) sieve in accordance with Method D 2013 or Practice D 346.

7.2 Transfer approximately 1 g (weighed to the nearest 0.1 mg) of the thoroughly mixed sample to a weighed capsule and cover quickly. An alternative way is to use the dried coal from the moisture determination in Test Method D 3173. After removing the covers, place the capsule containing the sample in a cold furnace and heat gradually at such a rate that the temperature reaches 450 to 500°C in 1 h.

7.3 Heat coal samples so that a final temperature of 700 to 750°C is reached by the end of the second hour. Heat coke samples so that a final temperature of 950°C is reached by the end of the second hour. Continue to heat at the final temperature for additional 2 h (see Note 1). Remove the capsule from the muffle, place the cover on the capsule, cool under conditions to minimize moisture pickup, and weigh.

NOTE 1—While the 4-h incineration interval described is sufficient with most coals to reach a condition of complete burn off, certain cokes and nonreactive coals may require additional time. If unburned carbon particles are observed, or if duplicate results are suspect, the samples should be returned to the furnace for sufficient time to reach a constant weight (± 0.001 g). By this means, pyritic sulfur will be oxidized and