

---

---

**Adhesives — Determination of dynamic  
resistance to cleavage of high-strength  
adhesive bonds under impact  
conditions — Wedge impact method**

*Adhésifs — Détermination de la résistance dynamique à un clivage de  
joints collés à haute résistance soumis aux conditions d'impact —  
Méthode d'impact au coin*

**iTeh STANDARD PREVIEW  
(standards.iteh.ai)**

[ISO 11343:2003](https://standards.iteh.ai/catalog/standards/sist/b4437d68-4ef1-49ae-9f0f-cb4993bf2257/iso-11343-2003)

<https://standards.iteh.ai/catalog/standards/sist/b4437d68-4ef1-49ae-9f0f-cb4993bf2257/iso-11343-2003>



**PDF disclaimer**

This PDF file may contain embedded typefaces. In accordance with Adobe's licensing policy, this file may be printed or viewed but shall not be edited unless the typefaces which are embedded are licensed to and installed on the computer performing the editing. In downloading this file, parties accept therein the responsibility of not infringing Adobe's licensing policy. The ISO Central Secretariat accepts no liability in this area.

Adobe is a trademark of Adobe Systems Incorporated.

Details of the software products used to create this PDF file can be found in the General Info relative to the file; the PDF-creation parameters were optimized for printing. Every care has been taken to ensure that the file is suitable for use by ISO member bodies. In the unlikely event that a problem relating to it is found, please inform the Central Secretariat at the address given below.

**iTeh STANDARD PREVIEW**  
**(standards.iteh.ai)**

[ISO 11343:2003](https://standards.iteh.ai/catalog/standards/sist/b4437d68-4ef1-49ae-9f0f-cb4993bf2257/iso-11343-2003)

<https://standards.iteh.ai/catalog/standards/sist/b4437d68-4ef1-49ae-9f0f-cb4993bf2257/iso-11343-2003>

© ISO 2003

All rights reserved. Unless otherwise specified, no part of this publication may be reproduced or utilized in any form or by any means, electronic or mechanical, including photocopying and microfilm, without permission in writing from either ISO at the address below or ISO's member body in the country of the requester.

ISO copyright office  
Case postale 56 • CH-1211 Geneva 20  
Tel. + 41 22 749 01 11  
Fax + 41 22 749 09 47  
E-mail [copyright@iso.org](mailto:copyright@iso.org)  
Web [www.iso.org](http://www.iso.org)

Published in Switzerland

**Contents**

Page

Foreword.....	iv
1 Scope.....	1
2 Normative references .....	1
3 Terms and definitions .....	1
4 Principle .....	2
5 Apparatus.....	2
6 Specimens .....	3
7 Test procedure .....	6
8 Expression of results.....	7
9 Precision .....	7
10 Test report.....	7

**iTeh STANDARD PREVIEW**  
**(standards.iteh.ai)**

[ISO 11343:2003](https://standards.iteh.ai/catalog/standards/sist/b4437d68-4ef1-49ae-9f0f-cb4993bf2257/iso-11343-2003)

<https://standards.iteh.ai/catalog/standards/sist/b4437d68-4ef1-49ae-9f0f-cb4993bf2257/iso-11343-2003>

## Foreword

ISO (the International Organization for Standardization) is a worldwide federation of national standards bodies (ISO member bodies). The work of preparing International Standards is normally carried out through ISO technical committees. Each member body interested in a subject for which a technical committee has been established has the right to be represented on that committee. International organizations, governmental and non-governmental, in liaison with ISO, also take part in the work. ISO collaborates closely with the International Electrotechnical Commission (IEC) on all matters of electrotechnical standardization.

International Standards are drafted in accordance with the rules given in the ISO/IEC Directives, Part 2.

The main task of technical committees is to prepare International Standards. Draft International Standards adopted by the technical committees are circulated to the member bodies for voting. Publication as an International Standard requires approval by at least 75 % of the member bodies casting a vote.

Attention is drawn to the possibility that some of the elements of this document may be the subject of patent rights. ISO shall not be held responsible for identifying any or all such patent rights.

ISO 11343 was prepared by Technical Committee ISO/TC 61, *Plastics*, Subcommittee SC 11, *Products*.

This second edition cancels and replaces the first edition (ISO 11343:1993), which has been technically revised.

ITIH STANDARD PREVIEW

(standards.iteh.ai)

ISO 11343:2003

<https://standards.iteh.ai/catalog/standards/sist/b4437d68-4ef1-49ae-9f0f-cb4993bf2257/iso-11343-2003>

# Adhesives — Determination of dynamic resistance to cleavage of high-strength adhesive bonds under impact conditions — Wedge impact method

## 1 Scope

This International Standard specifies a dynamic impact wedge method for the determination of the cleavage resistance under impact loading of high-strength adhesive bonds between two metallic adherends, when tested under specified conditions of preparation and testing. This test procedure does not provide design information.

The method allows a choice of sheet metal substrate corresponding to those materials frequently used in industry, e.g. for automotive applications.

## 2 Normative references

The following referenced documents are indispensable for the application of this document. For dated references, only the edition cited applies. For undated references, the latest edition of the referenced document (including any amendments) applies.

ISO 291:1997, *Plastics — Standard atmospheres for conditioning and testing*  
<https://standards.iso.org/standards.html?std=42716&cl=9&sf=cb4993bf2257/iso-11343-2003>

ISO 10365:1992, *Adhesives — Designation of main failure patterns*

EN 13887:—<sup>1)</sup>, *Structural adhesives — Guidelines for surface preparation of metals and plastics prior to adhesive bonding*

## 3 Terms and definitions

For the purposes of this document, the following terms and definitions apply.

### 3.1

#### **dynamic resistance to cleavage**

force per unit width necessary to bring an adhesive joint to the point of failure by means of a stress applied by a wedge moving between the two substrates of the joint, and thus separating the adherends in a peeling mode

NOTE It is expressed in kilonewtons per metre.

---

1) To be published.

## 4 Principle

The method consists of the determination of the average cleavage resistance, expressed as force or energy, of the adhesive bond between two metallic adherends. The cleavage corresponds to the separation of the adherends by a wedge, moving at high speed, whose displacement is initiated by an impact.

## 5 Apparatus

**5.1 Instrumented impact-testing machine**, capable of applying an impact energy of at least 50 J and preferably up to 300 J and an impact speed of at least 3 m/s and preferably up to 5,5 m/s. It shall be provided with a suitable grip to hold the specimen. The jaws of this grip shall firmly engage the outer part of the ends of the metallic adherends and shall have provision for positive location of these adherends by means of a hardened-steel bolt passing through the grips and through an 8 mm hole predrilled in the specimens, to clamp the assembly together.

The machine shall be equipped with an instrument capable of registering and storing the force data during the impact event, as a function of time or displacement of the wedge. The response time shall be at least an order of magnitude shorter than the impact event. The machine shall be equipped with a microprocessor/computer in order to perform the necessary calculations for expression of the results. Figure 1 represents a pendulum-type impact machine, using a piezoelectric transducer fixed to the specimen clamp.

NOTE 1 Falling-weight and servohydraulic-impact machines may be used for this test in addition to pendulum machines. Suitable machines are commercially available<sup>2)</sup>.

NOTE 2 Data collection is controlled by the machine type. A servohydraulic machine provides both force-time and force-displacement data, while a pendulum-type or a falling-weight machine provides force-time and, by calculation, force-displacement data. Therefore, both types of data are allowed.

NOTE 3 The machine should be equipped with an environmental chamber to allow conditioning and testing at different temperatures if required.

**5.2 Test wedge**, made of hardened steel, for cleaving the specimen (see Figures 2 and 3, symmetric and asymmetric wedges).

The wedge, attached to its support frame which has a vertical degree of freedom, is pulled through the adhesive joint by the force of the impact on the frame. Because of the degree of freedom, the wedge aligns itself with the adhesive joint during the test. The included angle of the wedge, its leading-edge radius and its maximum depth will determine the progression of opening of the bonded joint ahead of the wedge tip. The wedge surface condition and state of cleanliness shall be maintained and inspected before each determination, since friction unduly increases the energy consumed.

The three-dimensional diagram in Figure 4 shows the interrelation of the path of the impact head and the positions of the wedge and the test specimen.

**5.3 Device for measuring thickness**, with an accuracy of  $\pm 0,01$  mm.

**5.4 Wedge support frame**, consisting of two parallel steel bars with the wedge fixed between them (at one of their ends) and a steel crosshead, for receiving the impact, positioned parallel to the wedge and connected perpendicular to the two bars at their other ends. The bar cross-section shall be 6,0 mm to 6,5 mm wide by 4,5 mm to 5,0 mm high. The total mass of the assembly shall be  $820 \text{ g} \pm 5 \text{ g}$ .

2) Suppliers of such machines are: Rosand Precision Ltd., Balds Lane, Lye, Stourbridge, West Midlands, DY9 8SH, UK, and Zwick GmbH & Co., P.O. Box 4350, D-7900, Ulm-Eisingen, Germany. This information is given for the convenience of users of this International Standard and does not constitute an endorsement by ISO of the products supplied. Equivalent products may be used if they can be shown to lead to the same results.

Dimensions in millimetres

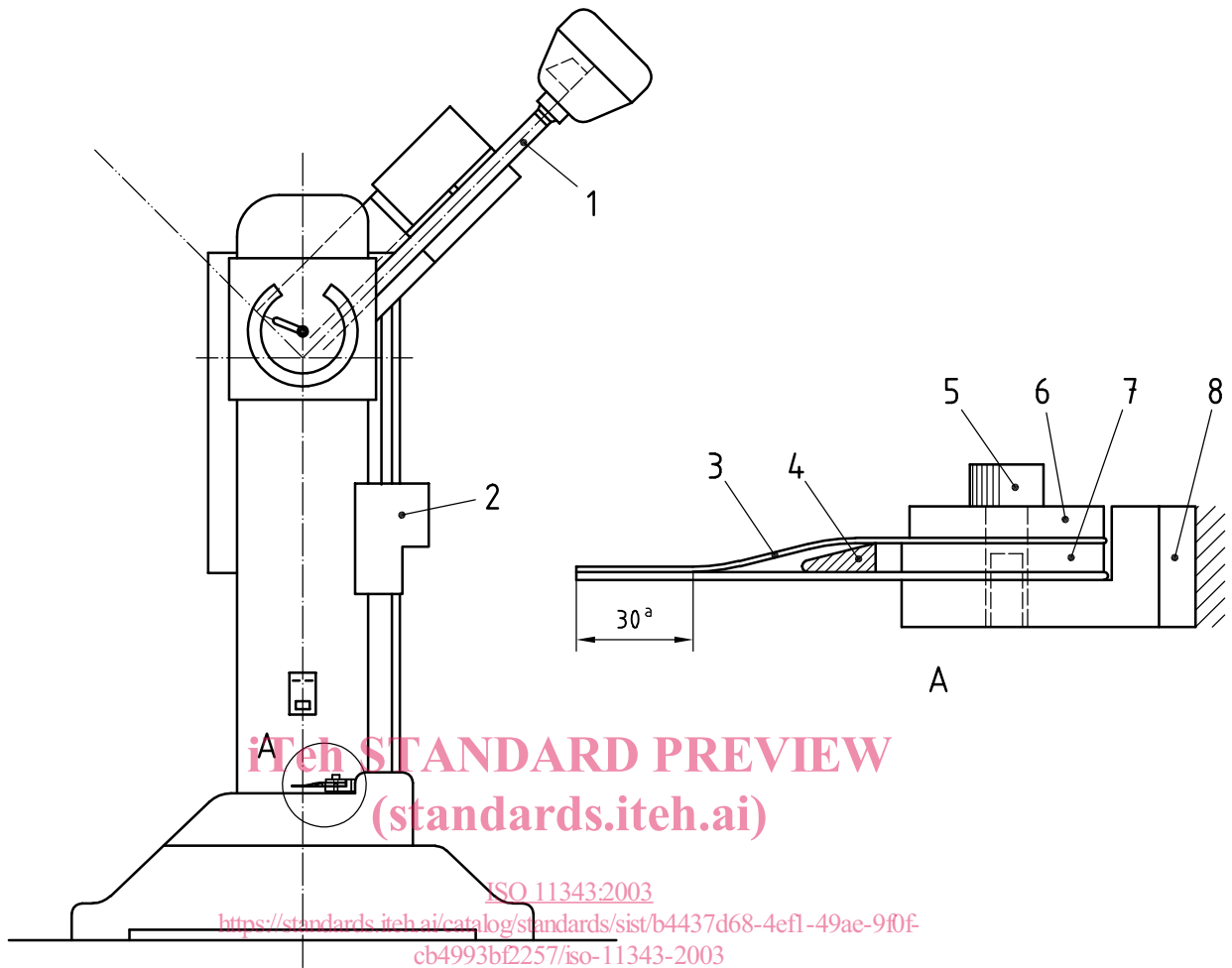
**Key**

- |  |                           |
|--|---------------------------|
| 1 pendulum   | 5 specimen-retaining bolt |
| 2 sliding unit for setting initial pendulum height | 6 clamping plate          |
| 3 specimen   | 7 spacer                  |
| 4 wedge  | 8 transducer              |

<sup>a</sup> adhesive region

**Figure 1 — Example of pendulum-type impact machine**

## 6 Specimens

**6.1** Specimens of the dimensions as shown in Figures 2 and 3 shall be prepared individually, and shall consist of two adherends properly prepared and bonded together.

**6.2** Surface treatment shall be such as to obtain consistent results in the bonded assembly. Thus the preparation of the surfaces shall be in accordance with either the adhesive manufacturer's instructions or EN 13887. When a surface contaminant, e.g. oil, is required for the purpose of the test, then it shall be applied in a manner that ensures uniformity between specimens.

The adhesive shall be applied in accordance with the manufacturer's instructions to obtain an optimum bond with minimum variation.

**NOTE** Direct comparison of different adhesives can be made only when specimen construction, adherend materials and dimensions, and test conditions are identical.

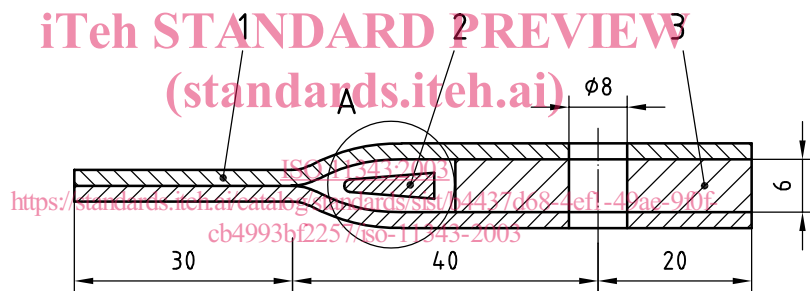
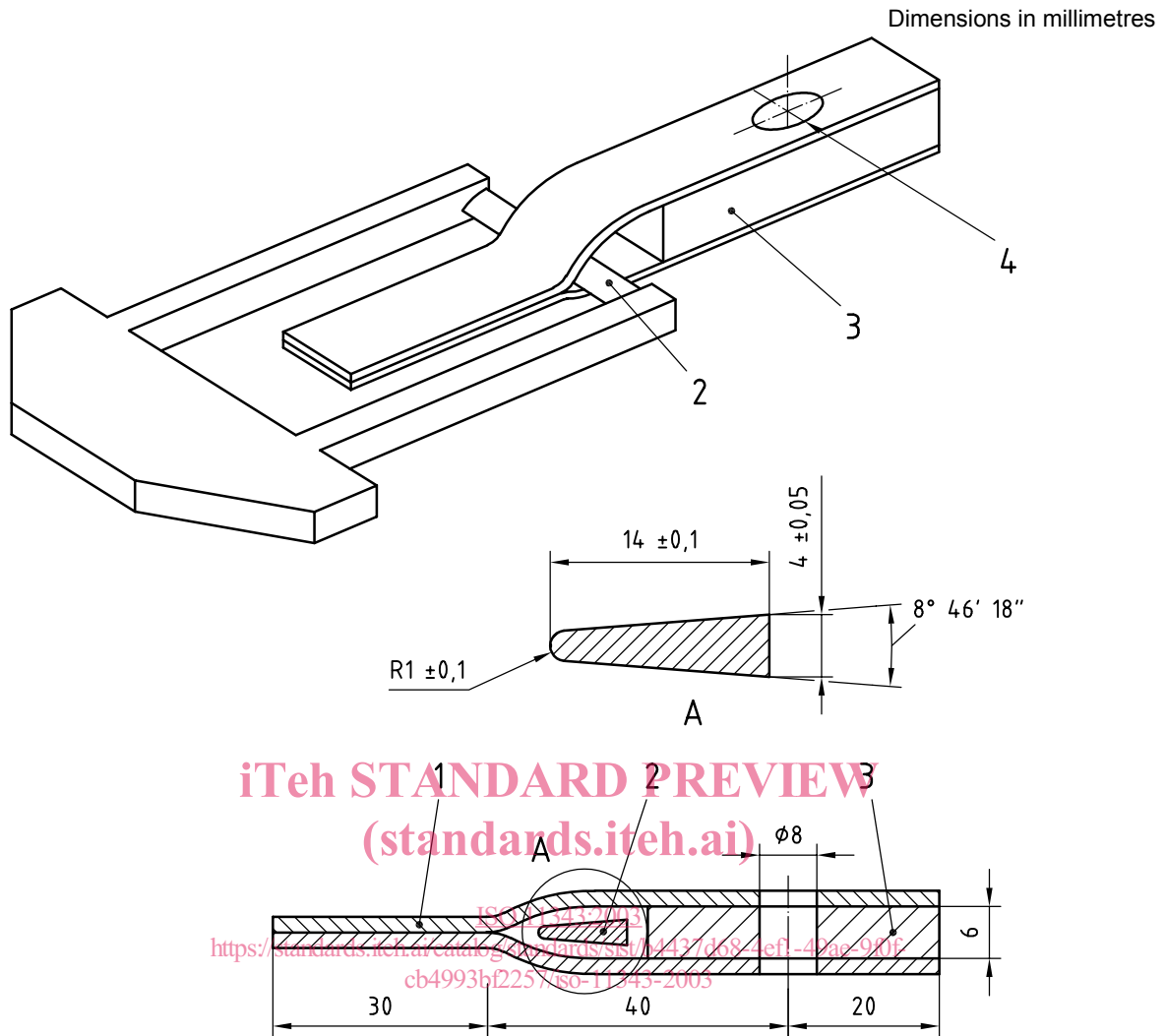

- Key**
- 1 specimen
  - 2 wedge
  - 3 spacer
  - 4 bolt hole

**Figure 2 — Symmetric wedge**

**6.3** The thickness of the adherends shall be chosen from sheet materials representative of industrial manufacturing and shall fall into the range 0,6 mm to 1,7 mm.

Where two adherends of different thicknesses are to be tested or where the adherends are of different modulus, the asymmetric wedge shall be employed with the higher-modulus or thicker adherend aligned with the bottom, flat side of the wedge. Where the adherends are identical, the symmetric wedge shall be employed.

**6.4** Specimens shall be prepared individually.

The width shall be either

- a) 20 mm (preferred)

or

- b) any other convenient width, provided that the test equipment is suitably adapted and the width is given in the test report.

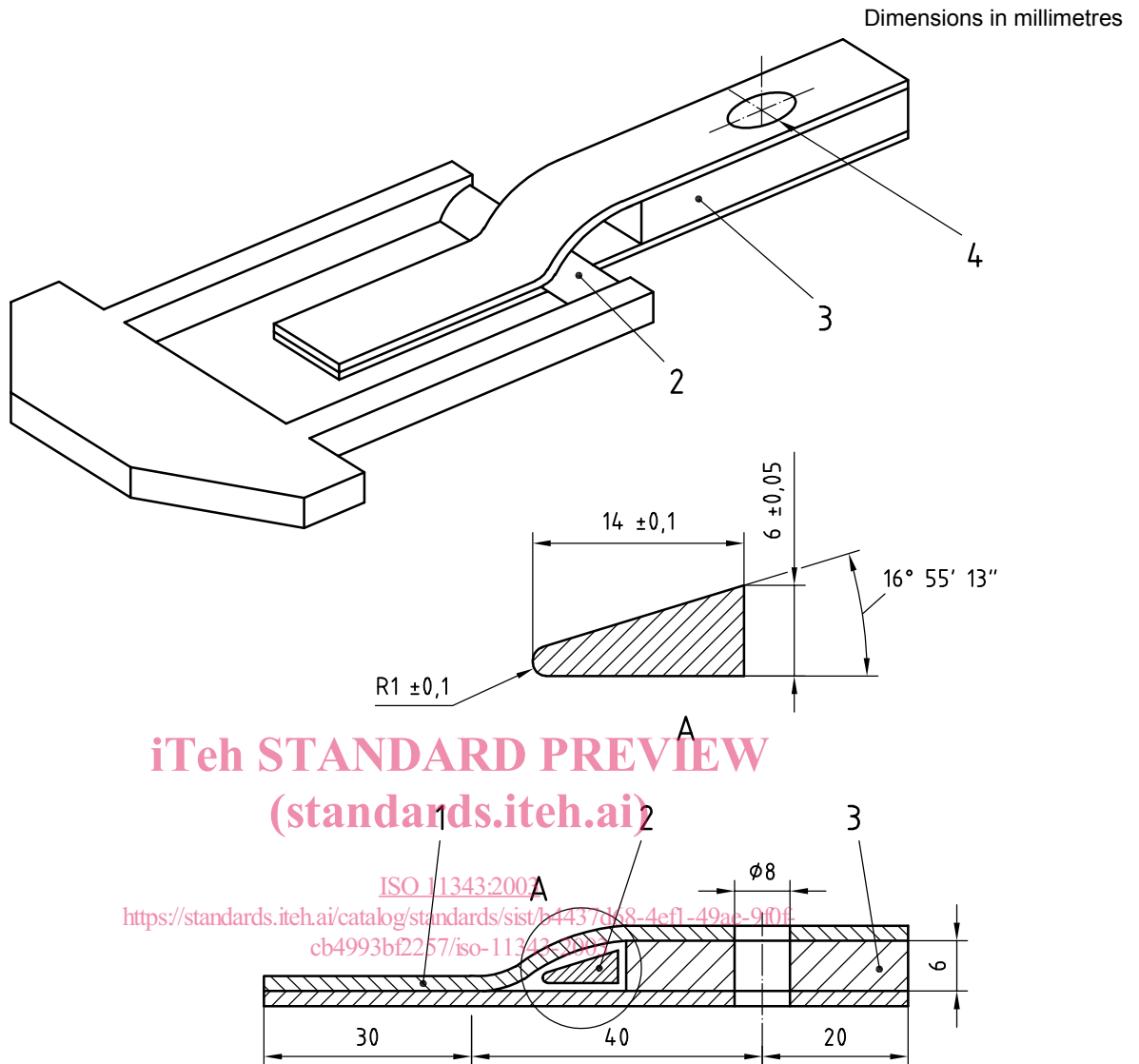

**Key**

- 1 specimen
- 2 wedge
- 3 spacer
- 4 bolt hole

**Figure 3 — Asymmetric wedge**

**6.5** The unbonded ends of the adherends shall be bent to allow clamping in the grip of the test machine. Adherends preformed to the shape of the wedge may also be used. When using the asymmetric wedge, only the top, thinner or lower-modulus adherend shall be bent.

**6.6** The number of specimens to be tested shall be five or more.

**6.7** The thickness of the adhesive layer after formation of the bond shall be determined on at least five specimens, to an accuracy of 0,01 mm (see 5.3). The maximum bond thickness shall be 2 mm. Specimens with a bond thickness greater than this shall be discarded.

**6.8** The specimens shall be conditioned and tested in one of the standard laboratory atmospheres specified in ISO 291.