



# Standard Specification for Residential Basketball Systems<sup>1</sup>

This standard is issued under the fixed designation F 1882; the number immediately following the designation indicates the year of original adoption or, in the case of revision, the year of last revision. A number in parentheses indicates the year of last approval. A superscript epsilon ( $\epsilon$ ) indicates an editorial change since the last revision or reapproval.

## 1. Scope

1.1 This specification covers the manufacture, assembly, recommended maintenance and use of complete residential basketball systems.

1.2 This specification is intended to reduce the potential hazards associated with the installation and use of residential basketball systems.

1.3 This specification is not intended to apply to the following:

1.3.1 Equipment intended to be used in places of public assembly, such as, but not limited to, schools, parks, public and private recreational facilities.

1.3.2 Individual components, such as rim, backboard, pole, portable base system, net, or other component when that component is not sold as a complete residential basketball system as defined in this specification.

1.3.3 Any residential basketball system that is mounted to any structure or surface other than that which is purchased as part of a complete residential basketball system. Examples include, but are not limited to, roof mounting, wall mounting, or any locally or self-manufactured components.

1.3.4 Any basketball equipment that does not use a full size rim, 18-in. (45.72-cm) diameter, or is designed for operational heights of less than 6 ft 6 in. (1.98 m) from the playing surface to the bottom of the backboard.

1.3.5 Accessories and add-ons.

1.4 This specification shall apply only to products manufactured after six months from the date this specification is published.

1.5 This specification does not cover product performance or quality, except as related to safety.

1.6 The tests are intended to uncover hazards, rather than to demonstrate the reliability of the system. The fact that a mechanism or material of a system fails during testing only is relevant if the failure creates a potential hazard.

1.7 The rationale for provisions in this specification are given in Appendix X1 and Appendix X2.

1.8 The values stated in inch-pound units are to be regarded as the standard. The values given in parentheses are for information only.

1.9 *This standard does not purport to address all of the safety concerns, if any, associated with its use. It is the responsibility of the user of this standard to establish appropriate safety and health practices and determine the applicability of regulatory limitations prior to use.*

## 2. Referenced Documents

2.1 *ASTM Standards:*<sup>2</sup>

D 2240 Test Method for Rubber Property—Durometer Hardness

C 1048 Specification for Heat-Treated Flat Glass—Kind HS, Kind FT Coated and Uncoated Glass

F 1148 Consumer Safety Performance Specification for Home Playground Equipment

2.2 *Federal Standards:*

16 CFR 1303 Ban of Lead-Containing Paint and Certain Consumer Products Bearing Lead-Containing Paint<sup>3</sup>

16 CFR 1500.48 Technical Requirements for Determining a Sharp Point in Toys and Other Articles Intended for Use by Children Under 8-Years of Age<sup>3</sup>

16 CFR 1500.49 Technical Requirements for Determining a Sharp Metal or Glass Edge in Toys and Other Articles Intended for Use by Children Under 8-Years of Age<sup>3</sup>

2.3 ANSI Z535 Warning Labels<sup>4</sup>

## 3. Terminology

3.1 *Definitions of Terms Specific to This Standard:*

<sup>2</sup> For referenced ASTM standards, visit the ASTM website, www.astm.org, or contact ASTM Customer Service at service@astm.org. For *Annual Book of ASTM Standards* volume information, refer to the standard's Document Summary page on the ASTM website.

<sup>3</sup> Available from the Consumer Product Safety Commission, Washington, DC 20207.

<sup>4</sup> Available from National Electrical Manufacturers Association (NEMA), 1300 N. 17th St., Suite 1847, Rosslyn, VA 22209.

<sup>1</sup> This specification is under the jurisdiction of ASTM Committee F08 on Sports Equipment and Facilities and is the direct responsibility of F08.25 on Recreational Basketball Equipment.

Current edition approved June 1, 2004. Published June 2004. Originally approved in 1998. Last previous edition approved in 1998 as F 1882 – 98.

3.1.1 *accessories and add-ons (items not covered in 3.1.3, 3.1.6, 3.1.10 and 3.1.16–3.1.17), n*—including but not limited to, such things as ball returns, scoring and training devices, and including items attached to the system not intended for use in basketball.

3.1.2 *adjusting mechanism, n*—moveable components that lock structural components in the desired position to facilitate changes in rim height.

3.1.3 *backboard, n*—rigid, flat surface to provide rebound surface for a basketball.

3.1.4 *complete residential basketball system, n*—any combination of rim, net, backboard, portable or non-portable pole-type support system not specifically excluded in 1.3.1-1.3.5 that is designed and marketed by the original manufacturer to be used together, whether packaged together as a system, or separately as individual components.

3.1.5 *footing, n*—the method for securing the placement of the system into the ground.

3.1.6 *full-size rim, n*—moveable or fixed-type rim with an 18-in. (45.72-cm) inside diameter.

3.1.7 *ground base systems, n*—systems that have a main support pole attached in ground by a footing.

3.1.8 *hanging, v*—when a player briefly suspends their full weight from any point on the rim.

3.1.9 *maximum offset, n*—distance from the front of the base or pole, whichever extends furthest from the system, to the front face of the backboard.

3.1.10 *net, n*—a device that hangs below the rim that restricts the downward movement of the ball.

3.1.11 *normal access area, n*—as described in Fig. 1.

3.1.12 *normal use, n*—those safe-play modes that conform to the instructions that accompany the equipment. Misuse, alteration, or modification are not considered normal use.

3.1.13 *pinch, crush, shear points, n*—any point that entraps at one or more positions a 1/2-in. (13-mm) diameter neoprene rod. Entrapment shall mean that force of more than 2 lb (0.90 kg) is required to pull out the rod. The neoprene rods shall have a hardness reading between 50 and 60 as determined by a Type A Durometer as given in Test Method D 2240.

3.1.14 *pole joint, n*—mechanical method for connecting a multiple segment pole.

3.1.15 *portable base systems, n*—systems that have a ballast type support system that allows the system to be moved.

3.1.16 *residential basketball equipment, n*—equipment that is intended for the normal use and play in residential basketball that includes the components given in 3.1.3, 3.1.6, 3.1.10 and 3.1.17.

3.1.17 *supplemental restraint systems, n*—additional methods of adding stability over and above recommended ballast to portable base systems, that is ground stakes and additional weight.

3.1.18 *support system, n*—structure provided to support rim and backboard in playing position. Could include pole, portable base, or mounting brackets.

#### 4. General Requirements

4.1 A complete residential basketball system, represented as complying with this performance specification, shall meet all applicable requirements specified herein.

#### 5. Performance Requirements

5.1 *General*—The standards listed in 5.3-5.6 apply only to the normal access area as described in 3.1.11 and Fig. 1.

5.2 *Paint Toxicity*—All paints and finishes used on basketball equipment shall be in accordance with 16 CFR Part 1303.

5.3 *Edges, Points, and Surfaces*—Following assembly of the system, in accordance with the instructions to be provided to the consumer, there shall be no exposed sharp edges, points, or surfaces on any portion of the residential basketball equipment according to CPSC 16 CFR 1500.48 and 1500.49.

5.4 There shall be no pinch, crush, or shear points as defined in 3.1.13.

5.5 Moving parts or height adjustment mechanisms outside the normal access area, which could pose a finger entrapment problem, shall be noted clearly in the warning label on the system and the safety instructions for proper use to reduce the risk of injury.

5.6 *Hardware*—Hardware must comply with the section on Hardware, Nuts, and Bolts of Performance Specification F 1148.

5.6.1 An projections and protrusions must comply with CPSC Handbook for Playground Safety Publication 325 and Performance Specification F 1148.

5.6.2 Lock washers, self-locking nuts, or other locking means shall be provided for all permanently attached bolts.

#### 6. Stability/Structural Integrity

6.1 *Portable Base System Testing (To Be Performed by the Manufacturer)*—The test should be performed to determine the ability of the portable base system to withstand anticipated forces which act to tip, slide, or cause permanent deformation, or a combination thereof, to the system. Complete assembly/installation according to manufacturer's recommendations. The force for all tests shall be applied gradually within a period of 1 min and maintained for a period of 5 min. All tests are to be performed at a room temperature of  $68 \pm 5^\circ\text{F}$  ( $22 \pm 15^\circ\text{C}$ ). This test must be performed with rim at 10-ft (3.05-m) regulation height and through its entire recommended adjustment range. The system must be tested without additional supplemental restraint systems. After conducting the tests, there shall be no visible cracks, permanent deformation, breakage, or deterioration of any component that may adversely affect the structural integrity or safety of the equipment.

6.1.1 *Horizontal Testing (Fig. 2)*—To simulate a 40-mph (64.4-kph) wind force, calculate the square footage of the backboard and refer to Fig. 3 to determine the horizontal load required to replicate the wind force. For Test No. 1, apply this horizontal load as shown in Fig. 2. If the rim height at the point of load application drops more than 6 in. (15.24 cm), stop the test and reposition the pulley. Proceed to Test No. 2. For Test No. 2, if required, with pulley realigned 6 in. (15.2 cm) lower, reapply horizontal test load and check if rim height drops more than 6 in. (15.24 cm). If so, repeat in 6-in. (15.14-cm) pulley height reduction segments. The test must be performed in both forward and rearward directions, and the system must not tip over beyond the balance point, in accordance with Fig. 4.

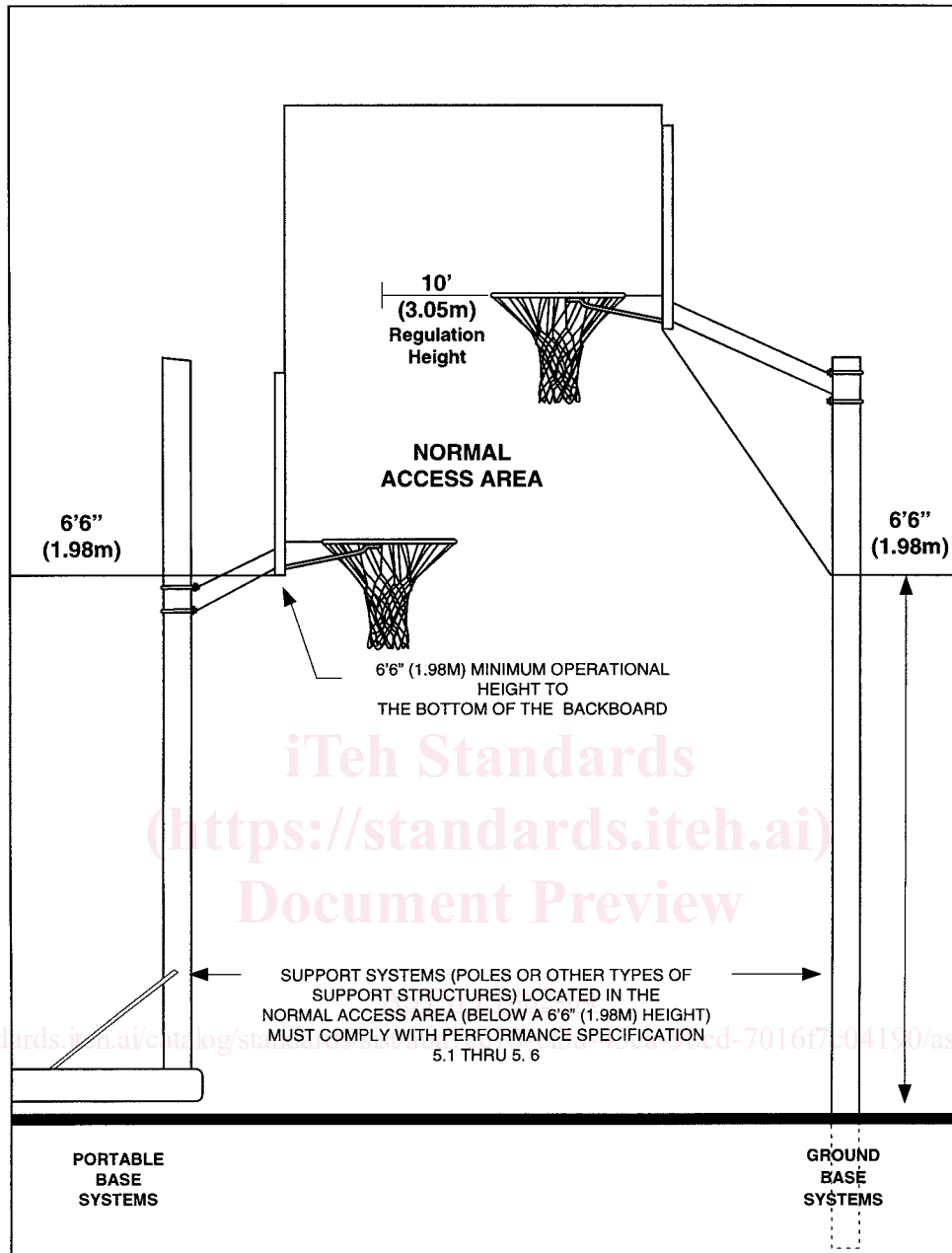
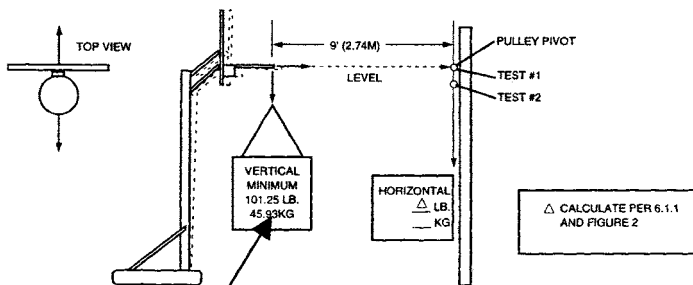

FIG. 1 Normal Access Area



Use only with 6.1.3 —

FIG. 2 Portable Base Horizontal and Vertical Testing

6.1.2 *Horizontal Rim Weight* (Fig. 5)—Determine the weight of the system (at the rim) while in a level horizontal position (80 lb (36.39 kg) max.

6.1.3 *Vertical Minimum Load* (Fig. 2)—This load is 101.25 lb (45.93 kg), and it must be applied vertically from the tip of the rim. With the required load, system must not tip over past its balance point in accordance with Fig. 4.

6.1.4 *Balance Point of System Testing* (Fig. 4)—Pull system forward to the point of balance where it will not fall forward or backward. The maximum distance between the tip of rim and the ground should be less than 5 ft 6 in. (1.68 m). When the

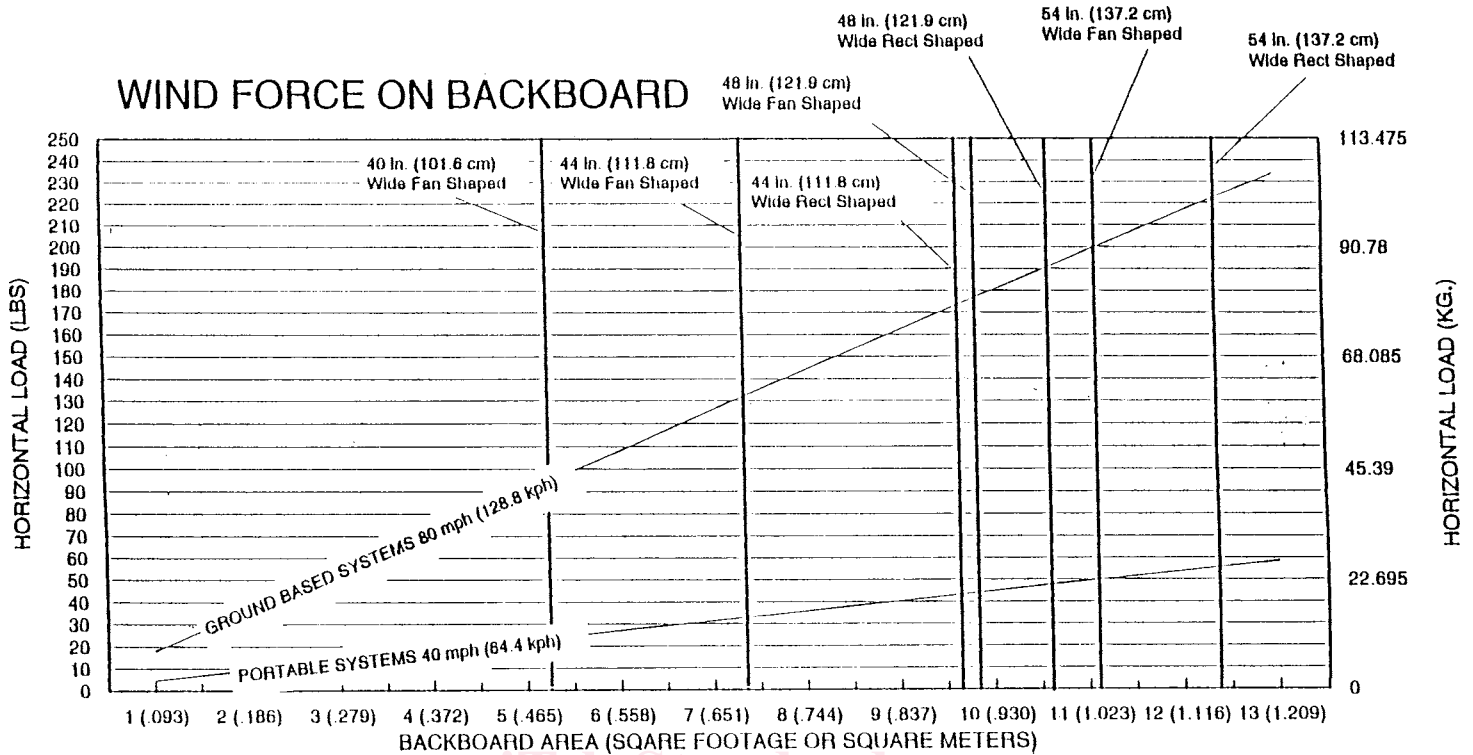

- Assumptions:**
- 1) Normal properties of air at sea level.
  - 2) Wind force acting on centroid of backboard area.
  - 3) Backboard surface is perpendicular to airflow.
  - 4) Backboard sizes indicated are approximate. Calculate exact backboard area using the actual dimensions of the backboard being tested.
  - 5) Load at rim assumes centroid is located 10% higher.

NOTE 1—The backboard sizes listed are for comparison use only. Each manufacturer is responsible for calculating and documenting the size of then backboard being tested.

FIG. 3 Wind Force on Backboard

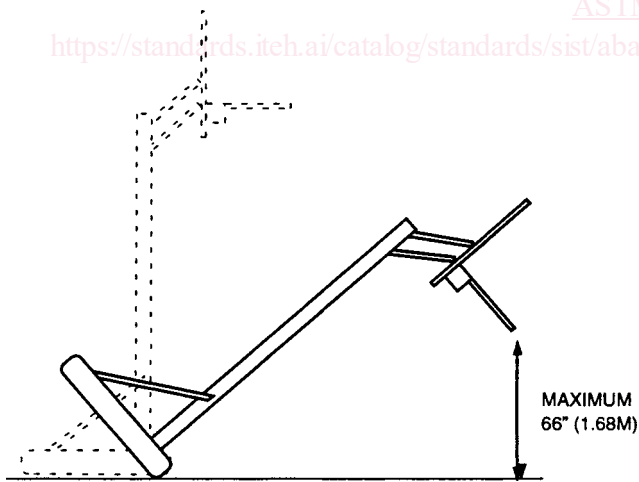

FIG. 4 Portable Base Balance Point of System Testing



FIG. 5 Portable Base Horizontal Rim Weight Determination

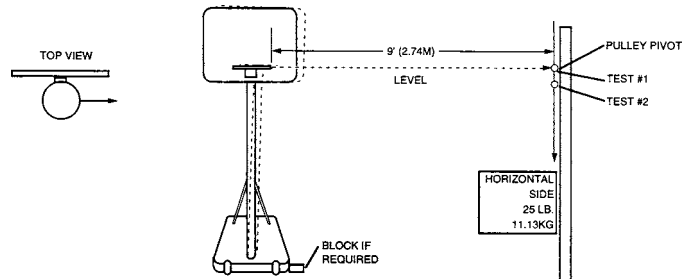

FIG. 6 Portable Base Horizontal Side Testing

system is released backwards above the natural balance point, it must return system to the normal upright position.

6.1.5 *Horizontal Side Testing (Fig. 6)*—With a 25-lb (11.34-kg) load, the portable system must not tip over sideways to such a point where the rim/backboard touches the ground.

6.1.6 *Portability Test on an Incline (Fig. 7)*—When following manufacturer’s recommendations for moving the portable

system, the system must remain in its transport (movable) position when placed on a 5° slope in any direction.

6.1.7 When following the manufacturer’s recommendations for moving the portable system, the system must be capable of being moved a distance of 50 ft (15.24 m).