



Standard Practice for Roof System Assemblies Employing Steel Deck, Preformed Roof Insulation, and Bituminous Built-Up Roofing¹

This standard is issued under the fixed designation E936; the number immediately following the designation indicates the year of original adoption or, in the case of revision, the year of last revision. A number in parentheses indicates the year of last reapproval. A superscript epsilon (ϵ) indicates an editorial change since the last revision or reapproval.

1. Scope

1.1 This practice covers the performance requirements for the design, components, construction, and service expectations of new roof system assemblies. For this purpose, the roof system always includes steel deck, preformed roof insulation, and bituminous built-up roofing, and their attachment. It may also include fire-resistive components, integral acoustical treatment, vapor retarder, adhesive or mechanical fastener attachment, and aggregates.

1.2 The objective is to provide realistic criteria for the overall performance of the roof assembly and its components because, by necessity and custom, a roof assembly contains a variety of components and is subject to varied environmental conditions.

1.3 To assist in the successful implementation of the installation and service requirements of the roof system assembly, criteria are established to provide for compatibility of the various components.

1.4 Nothing in this practice is intended to exclude products or systems not covered by the documents referenced in Section 2.

1.5 The values stated in either SI units or inch-pound units are to be regarded separately as standard. The values stated in each system are not exact equivalents; therefore, each system must be used independently of the other.

1.6 *This standard does not purport to address all of the safety concerns, if any, associated with its use. It is the responsibility of the user of this standard to establish appropriate safety and health practices and determine the applicability of regulatory limitations prior to use.*

¹ This practice is under the jurisdiction of ASTM Committee D08 on Roofing and Waterproofing and is the direct responsibility of Subcommittee D08.20 on Roofing Membrane Systems.

Current edition approved July 1, 2004. Published July 2004. Originally approved in 1983. Last previous edition approved in 1998 as E936 – 98. DOI: 10.1520/E0936-98R04.

2. Referenced Documents

2.1 ASTM Standards:²

- A446/A446M Specification for Steel Sheet, Zinc-Coated (Galvanized) by the Hot-Dip Process, Structural (Physical) Quality (Withdrawn 1994)³
- A529/A529M Specification for High-Strength Carbon-Manganese Steel of Structural Quality
- A570/A570M Specification for Structural Steel, Sheet and Strip, Carbon, Hot-Rolled (Withdrawn 2000)³
- A606 Specification for Steel, Sheet and Strip, High-Strength, Low-Alloy, Hot-Rolled and Cold-Rolled, with Improved Atmospheric Corrosion Resistance
- A607 Specification for Steel, Sheet and Strip, High-Strength, Low-Alloy, Columbium or Vanadium, or Both, Hot-Rolled and Cold-Rolled (Withdrawn 1998)³
- A611 Specification for Structural Steel (SS), Sheet, Carbon, Cold-Rolled (Withdrawn 2000)³
- A653/A653M Specification for Steel Sheet, Zinc-Coated (Galvanized) or Zinc-Iron Alloy-Coated (Galvannealed) by the Hot-Dip Process
- B117 Practice for Operating Salt Spray (Fog) Apparatus
- C177 Test Method for Steady-State Heat Flux Measurements and Thermal Transmission Properties by Means of the Guarded-Hot-Plate Apparatus
- C208 Specification for Cellulosic Fiber Insulating Board
- C209 Test Methods for Cellulosic Fiber Insulating Board
- C236 Test Method for Steady-State Thermal Performance of Building Assemblies by Means of a Guarded Hot Box (Withdrawn 2001)³
- C518 Test Method for Steady-State Thermal Transmission Properties by Means of the Heat Flow Meter Apparatus
- C550 Test Method for Measuring Trueness and Squareness

² For referenced ASTM standards, visit the ASTM website, www.astm.org, or contact ASTM Customer Service at service@astm.org. For *Annual Book of ASTM Standards* volume information, refer to the standard's Document Summary page on the ASTM website.

³ The last approved version of this historical standard is referenced on www.astm.org.

- of Rigid Block and Board Thermal Insulation
- C552** Specification for Cellular Glass Thermal Insulation
- C578** Specification for Rigid, Cellular Polystyrene Thermal Insulation
- C726** Specification for Mineral Wool Roof Insulation Board
- C728** Specification for Perlite Thermal Insulation Board
- C755** Practice for Selection of Water Vapor Retarders for Thermal Insulation
- C1013** Specification for Faced Rigid Cellular Polyisocyanurate Roof Insulation (Withdrawn 1997)³
- C1126** Specification for Faced or Unfaced Rigid Cellular Phenolic Thermal Insulation
- C1289** Specification for Faced Rigid Cellular Polyisocyanurate Thermal Insulation Board
- D41** Specification for Asphalt Primer Used in Roofing, Dampproofing, and Waterproofing
- D146** Test Methods for Sampling and Testing Bitumen-Saturated Felts and Woven Fabrics for Roofing and Waterproofing
- D226** Specification for Asphalt-Saturated Organic Felt Used in Roofing and Waterproofing
- D227** Specification for Coal-Tar-Saturated Organic Felt Used in Roofing and Waterproofing
- D244** Test Methods and Practices for Emulsified Asphalts
- D249** Specification for Asphalt Roll Roofing (Organic Felt) Surfaced with Mineral Granules (Withdrawn 2002)³
- D312** Specification for Asphalt Used in Roofing
- D371** Specification for Asphalt Roll Roofing (Organic Felt) Surfaced with Mineral Granules; Wide Selvage (Withdrawn 2002)³
- D450** Specification for Coal-Tar Pitch Used in Roofing, Dampproofing, and Waterproofing
- D1079** Terminology Relating to Roofing and Waterproofing
- D1227** Specification for Emulsified Asphalt Used as a Protective Coating for Roofing
- D1310** Test Method for Flash Point and Fire Point of Liquids by Tag Open-Cup Apparatus
- D1863** Specification for Mineral Aggregate Used on Built-Up Roofs
- D2178** Specification for Asphalt Glass Felt Used in Roofing and Waterproofing
- D2626** Specification for Asphalt-Saturated and Coated Organic Felt Base Sheet Used in Roofing
- D2822** Specification for Asphalt Roof Cement, Asbestos-Containing
- D2823** Specification for Asphalt Roof Coatings, Asbestos-Containing
- D2824** Specification for Aluminum-Pigmented Asphalt Roof Coatings, Nonfibered, Asbestos Fibered, and Fibered without Asbestos
- D2829** Practice for Sampling and Analysis of Existing Built-Up Roof Systems
- D3617** Practice for Sampling and Analysis of Built-Up Roof Systems During Application
- D3909** Specification for Asphalt Roll Roofing (Glass Felt) Surfaced With Mineral Granules
- D4077** Specification for Cumene (Isopropylbenzene)
- D4479** Specification for Asphalt Roof Coatings—Asbestos-Free
- D4586** Specification for Asphalt Roof Cement, Asbestos-Free
- D4601** Specification for Asphalt-Coated Glass Fiber Base Sheet Used in Roofing
- D4897** Specification for Asphalt-Coated Glass-Fiber Venting Base Sheet Used in Roofing
- D4990** Specification for Coal Tar Glass Felt Used in Roofing and Waterproofing
- E84** Test Method for Surface Burning Characteristics of Building Materials
- E96/E96M** Test Methods for Water Vapor Transmission of Materials
- E108** Test Methods for Fire Tests of Roof Coverings
- E119** Test Methods for Fire Tests of Building Construction and Materials
- E196** Practice for Gravity Load Testing of Floors and Low Slope Roofs
- E241** Guide for Limiting Water-Induced Damage to Buildings
- E541** Specification for Agencies Engaged in System Analysis and Compliance Assurance for Manufactured Building
- E631** Terminology of Building Constructions
- E651/E651M** Practice for Evaluating Capabilities of Agencies Involved in System Analysis and Compliance Assurance for Manufactured Building
- E699** Practice for Evaluation of Agencies Involved in Testing, Quality Assurance, and Evaluating of Building Components
- E907** Test Method for Field Testing Uplift Resistance of Adhered Membrane Roofing Systems
- 2.2 *Factory Mutual Research Corporation (FM) Documents:*⁴
- FM Approval Guide**
Approval Standard 4450
Class I Steel Deck Roofs
Approval Standard 4451 for Steel Deck Nominal 1½ in. Deep As Component of Class I Insulated Steel Roof Deck Construction
Approval Standard 4470 Class I Roof Covers
- FM 1-28** Loss Prevention Data Insulated Steel Deck
- FM-1-48** Loss Prevention Data SH Repair Procedures for Built-Up Roof Coverings Over Steel Decks
- FM-1-49** Loss Prevention Data SH Perimeter Flashing
- FM-1-52** Loss Prevention Data Wind Uplift
- 2.3 *Underwriters' Laboratories, Inc. (UL) Documents:*⁵
- Roofing Materials and Systems Directory**
Publication No. 1256—Outline of the Proposed Investigation for Roof Deck Construction
- U.L. 580** Standard for Safety, Tests for Wind Uplift Resistance of Roof Assemblies
- Fire Resistance Directory**

⁴ Available from Factory Mutual Research Corporation, P.O. Box 688, Norwood, MA 02062.

⁵ Available from Underwriters Laboratories (UL), Corporate Progress, 333 Pfingsten Rd., Northbrook, IL 60062.

2.4 *National Roofing Contractors Association (NRCA) Document*.⁶

NRCA Energy Manual
Bulletin 2-91
Equiviscous Temperature (EVT)
NRCA/ARMA Manual of Roof Maintenance and Repair
ARMA/NRCA Quality Control Guidelines for the Application of Built-Up Roofing
Roofing and Waterproofing Manual, 1989
In Service R-Values (ISR) for Polyisocyanurate and Polyurethane Roof Insulation Boards

2.5 *Steel Deck Institute (SDI) Document*.⁷
Steel Deck Institute Design Manual

2.6 *American Iron and Steel Institute (AISI) Standards*.⁸
Specification for the Design of Cold Formed Steel Structural Members, August 19, 1986 Edition

2.7 *American Institute of Architects (AIA)*.⁹
Roof System Design Manual

2.8 *Canadian Roofing Contractors Association (CRCA)*.¹⁰
Roofing Manual

2.9 *American Society of Heating, Refrigerating and Air-Conditioning Engineers (ASHRAE)*.¹¹
Roofing Insulation Recommendations

2.10 *Sheet Metal and Air Conditioning Contractors National Association Standard*.¹²
Architectural Sheet Metal Manual, SMACMA

2.11 *The Aluminum Association Incorporated Standard*.¹³
Specification for Aluminum Sheet Metal Work in Building Construction

2.12 *Copper Development Association, Inc. Documents*.¹⁴
Architectural Applications 405/7R
Base and Cap Flashings 402/9
Sheet Copper Fundamentals 406/9
Building Expansion Joints 408/70

2.13 *American Welding Society (AWS) Standard*.¹⁵
AWS D1.3-81, Specification for Welding Sheet Steel in Structures

⁶ Available from National Roofing Contractors Assoc., 10255 West Higgins Road, Suite 600, Rosemont, IL 60018-5607.

⁷ Available from Steel Deck Institute (SDI), PO Box 25, Fox River Grove, IL 60021-0025.

⁸ Available from American Iron and Steel Institute (AISI), 1101 17th St., NW, Suite 1300, Washington, DC 20036.

⁹ Available from American Institute of Architects, 1735 New York Ave., NW, Washington, DC 20006.

¹⁰ Available from Canadian Roofing Contractors Assn., 155 Queen St., Suite 1300, Ottawa, Ontario Canada K1P 6L1.

¹¹ Available from American Society of Heating, Refrigerating, and Air-Conditioning Engineers, Inc. (ASHRAE), 1791 Tullie Circle, NE, Atlanta, GA 30329.

¹² Available from Sheet Metal and Air Conditioning Contractors' National Assn., 4201 Lafayette Center Drive, Chantilly, VA 22021.

¹³ Available from The Aluminum Association, 818 Connecticut Ave. NW, Washington, DC 20006.

¹⁴ Available from Copper Development Assn., Inc., 260 Madison Ave., 16th Fl., New York, NY 10016.

¹⁵ Available from The American Welding Society (AWS), 550 NW LeJeune Rd., Miami, FL 33126.

2.14 *National Institute of Standards and Technology Publications*.¹⁶

Building Science Series No. 9—Thermal Shock Resistance for Built-up Membranes
Building Science Series No. 55—Preliminary Performance Criteria for Bituminous Membrane Roofing
Building Science Series No. 92—Viscosities of Roofing Asphalts at Application Temperatures
Technical Note 473—Laboratory Field Comparisons of Built-up Roofing Membranes

2.15 *Midwest Roofing Contractors Association Document*.¹⁷
Ten Years of Roofing Research

3. Terminology

3.1 *Definitions*—Refer to Terminology D1079 and Terminology E631.

4. Performance Concepts

4.1 *Design*—The roof system should be designed in accordance with this practice to resist the effects of the usual or normal weather and loading conditions which can cause excessive deflection, destroy adhesive bond, fracture the insulation, and result in premature failure of the roof system. Such weather and loading conditions may include, but are not confined to water, wind, hail, snow, ice, and uniform and concentrated loading, and thermal expansion and contraction of building units. The roof system should be sloped to provide drainage under design loading conditions and the design should sustain the anticipated live load if drainage is obstructed (see 16.4).

4.2 *Construction*—During construction, the partially completed and the completed roof assembly should (1) be protected against construction traffic and equipment to be used in the construction of the roof assembly and subsequent traffic and use by other trades and (2) provide weather protection consistent with the construction schedule requirements as determined by the existing weather conditions.

4.3 *Service*—The roof system assembly when in service should:

4.3.1 Be protected against anticipated building maintenance procedures.

4.3.2 Provide weather protection.

4.3.3 Provide thermal insulation.

4.3.4 Provide a vapor retarder, if required.

4.3.5 Provide fire safety and uplift resistance as required by the building owner, applicable building codes, or insurance underwriters.

4.3.6 Carry anticipated design dead loads and live loads.

4.3.7 Receive proper and periodic maintenance over its service life.

4.4 The components used in the roof system assembly should be compatible with each other.

¹⁶ Available from National Institute of Standards and Technology, 100 Bureau Dr., Stop 3460, Gaithersburg, MD 20899-3460.

¹⁷ Available from Midwest Roofing Contractors Assn., 4840 West 15th St., Suite 1000, Lawrence, KS 66049-3876.

5. Design, Materials, and Construction Requirements

5.1 All components of the roof system should conform to specific design criteria essential to provide an assembly capable of fulfilling the performance concepts.

NOTE 1—The spacing and straightness, stiffness, and strength of the steel deck supports are important to proper deck installation and should be confirmed by the designer or their representative.

NOTE 2—For locations other than roof edge and nonwall supported details, the need for wood nailers should be determined by the designer or specifier.

NOTE 3—The first layer of the preformed insulation can be more positively secured by mechanical fasteners with the additional layers of preformed insulation fully adhered to the first layer.

5.2 The design should be in accordance with the owner’s insurance carrier’s requirements, when applicable.

5.3 The performance of all roof-system components and the roof system itself should be confirmed by test procedures. These procedures shall be those established by recognized agencies including, but not confined to, independent testing agencies acceptable to the authority having jurisdiction.

5.3.1 Performance of individual components of the roof system evaluated by on-site testing is covered under materials guidelines in Sections 6-12, inclusive.

5.4 Construction materials should be protected after manufacture, while in transit or storage, and at the job site.

5.4.1 Damaged materials should not be installed.

5.5 A pre-roofing conference should be conducted prior to the erection or assembly of the roof system (Appendix X2.9).

REQUIREMENTS FOR COMPONENTS

6. Steel Roof Deck

6.1 Design Guidelines—The steel deck should be designed in accordance with the following provisions:

NOTE 4—Load tables based on uniformly distributed loads are not the sole determinant of deck section because concentrated loads (in excess of 1.3 kN [300 lb]) common to construction practice, may control span lengths.

6.1.1 Section Properties—The Section Modulus and Moment of Inertia should be computed in accordance with AISI Specification for the Design of Cold-Formed Steel Structural Members.

6.1.2 Yield Strength—The minimum yield strength of the steel, f_y , should be 228 MPa [33 000 psi]. The unit design stress or working stress, f_d , or both, should not exceed 250 MPa [36 000 psi] or the minimum yield strength of the steel multiplied by 0.60, whichever is the lesser, [that is, $f_d \leq 0.60 f_y$ not to exceed 250 MPa [36 000 psi]].

NOTE 5—The hardness of the steel deck should be considered when selecting the insulation fasteners.

6.1.3 Allowable-Span Determinations—The maximum allowable span for the steel deck should be the least of three computational determinations for span predicated on deflection and stress limitations under specific concentrated and uniform loading conditions as follows:

6.1.3.1 Span based on concentrated loading deflection: When subjected to a minimum 1.3 kN [300-lb] concentrated load representing construction loading, located at midspan of a single-span deck, or at midspan of an end span where the deck

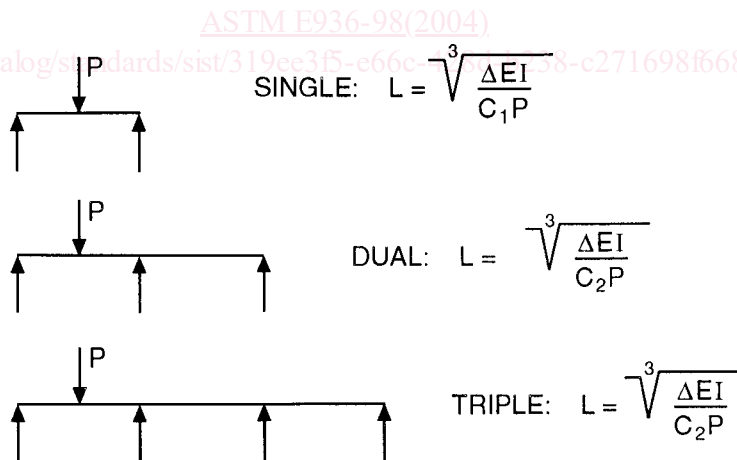

- P = Concentrated load, newtons/m width [pounds/ft width]. Concentrated load = line load normal to the span. Use 2.9 kN/m width [200 lbf/ft width] minimum.
- L = Span, millimetres [inches], center to center of supports [end or intermediate], applicable to equal spans only. For unequal spans, other formulas are available.
- I = Moment of inertia of steel deck, m⁴/m width [in.⁴/ft width].
- E = Modulus of Elasticity of steel = 2.0 × 10⁵ MPa [29.5 × 10⁶ psi]
 Note—1 MPa = 10⁶ N/m² and use of MPa value compensates for dimensional adjustments in formulas.
- Δ = Deflection, millimetres [inches] usually limited to L/240.
- C₁ = 0.021 for SI and inch pound unit dimensions.
- C₂ = 0.015 for SI and inch pound unit dimensions.

NOTE 1—Independent tests have indicated that a concentrated load applied over a width less than or equal to 0.3 m [1 ft] and some nominal length will be distributed over or resisted by a 0.45 m [1.5 ft] width of deck when side laps are properly fastened and when sheets are greater than 0.3 m [1 ft] wide. This justifies using 2.9 kN/m width [200 lbf/ft width] to approximate an actual concentrated load of 1.3 kN [300 lbf].

FIG. 1 Span Based on Concentrated Loading Deflection

is continuous over two or more spans, the maximum allowable deck span should not exceed 240 times the deflection resulting from concentrated load. Span should be computed as shown in Fig. 1.

6.1.3.2 Maximum deck span based on deflection due to design uniform live load should not exceed 240 times the deflection. Span may be computed as shown in Fig. 2.

6.1.3.3 Maximum deck span based on stress due to design uniform total load (dead plus live) may be computed as shown in Fig. 3.

6.1.4 Side Lap—Side laps of individual sheets should be fastened together between supports so as to limit differential deflection of adjacent sheets between fasteners to 6 mm [¼ in.] or less when subjected to a 1.3 kN [300 lb] concentrated load. In no case shall the spacing of side-lap fastening between supports exceed 1 m [36 in.] (see 6.3.5.2).

6.1.5 Anchorage—At perimeters of roof areas, the deck should be supported to prevent differential deflection. Steel deck units should be anchored to the supporting framework by deck fasteners or welding. All deficient welds or mechanical fasteners should be replaced before installing other components. Steel deck and anchorage should resist the gross uplift force due to the anticipated wind velocity and internal building pressure on the roof being considered. The dead load of the roof-deck construction should be deducted from the above uplift forces.

6.1.6 Design Thickness, t_d —Deck manufacturers' published load tables, section properties, and maximum span should be based on decimal thickness. The uncoated minimum steel thickness of the cold-formed product as delivered to the job site shall not at any location be less than 95 % of the thickness used in its design, however, thicknesses may be less at bends such as

corners due to cold forming effects. The uncoated thickness for listed design thicknesses are shown in Table 1.

6.1.6.1 Decks may be manufactured to any decimal thickness in excess of 0.70 mm [0.028 in.], providing the thickness is no less than 95 % of the design thickness [0.95 t_d].

6.1.7 Steel Roof-Deck Shape—The configurations of steel roof decks vary among manufacturers, but the top surfaces should conform to the limitations in 6.2.3, top-flange surface. The top flange should provide a flat contact surface of no less than 50 % of the roof area.

6.1.7.1 Narrow Rib Deck—A deck whose rib opening, measured along the top surface at the theoretical intersection points of the flange and web projections, is 25 mm [1 in.] or less (see Fig. 4).

6.1.7.2 Intermediate Rib Deck—A deck whose rib opening, measured along the top surface at the theoretical intersection points of the flange and web projections, is greater than 25 mm [1 in.] up to and including 44 mm [1¾ in.] (see Fig. 5).

6.1.7.3 Wide Rib Deck—A deck whose rib opening, measured along the top surface at the theoretical intersection points of the flange and web projections, is greater than 44 mm [1¾ in.] up to and including 67 mm [2⅝ in.] (see Fig. 6).

6.1.7.4 Open Rib Deck—A deck whose rib opening, measured along the top surface at the theoretical intersection points of the flange and web projections, is greater than 67 mm [2⅝ in.] and up to and including 92 mm [3⅝ in.] maximum (see Fig. 7). This deck section should have a rib spacing of 200 mm [8 in.] or more.

6.1.8 Steel Roof-Deck Diaphragm Design—The deck may be designed to function as a diaphragm and sustain shear imposed by windstorm or seismic forces. Such construction

ASTM E936-98(2004)

<https://standards.iteh.ai/catalog/standards/sist/319ce3f5-e66c-48-c271698f668c/astm-e936-982004>

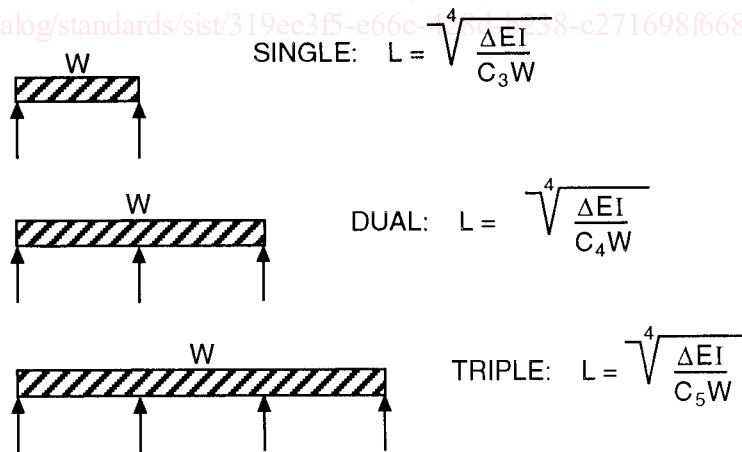

- W = Uniform Live Load, newtons/mm length, across a 1 metre wide section [pounds/inch length, across a 1 foot wide section].
- L = Span, millimetres [inches], center to center of supports (end or intermediate), applicable to equal spans only. For unequal spans, other formulas are available.
- I = Moment of inertia of steel deck, mm⁴/m width [in.⁴/foot width]. Note: This choice of units is dimensionally and conceptually consistent with "W".
- E = Modulus of Elasticity of steel = 2.0 × 10⁵ MPa [29.5 × 10⁶ psi]
Note—1 MPa = 10⁶ N/m² and use of MPa value compensates for dimensional adjustments in formulas.
- Δ = Deflection, millimetres [inches] usually limited to L/240.
- C₃ = 0.0130 for SI and inch pound unit dimensions.
- C₄ = 0.0054 for SI and inch pound unit dimensions.
- C₅ = 0.0069 for SI and inch pound unit dimensions.

NOTE 1—This choice of units is unusual but makes the formulas dimensionally admissible as presented—e.g. W = Newtons/mm*m and lbf/in.*ft.

FIG. 2 Span Based on Uniform Live Load Deflection

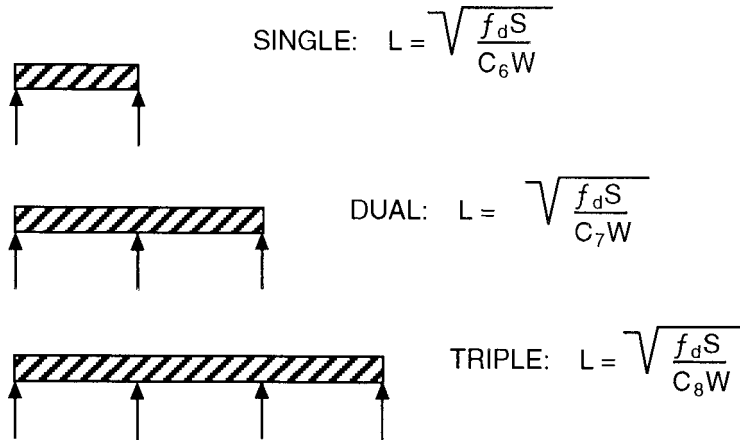

W = Uniform Load, newtons/mm length, across a 1 metre wide section [pounds/inch length across a 1 foot wide section].
 L = Span, millimetres [inches], center to center of supports (end or intermediate), applicable to equal spans only. For unequal spans, other formulas are available.
 f_d = Maximum allowable design stress for grade of steel being employed, megapascals [pounds per square inch].
 Note: 1 MPa = 10⁶ N/m² and the use of the MPa value provides the required dimensional adjustment in formulas.
 S = Section Modulus of steel deck, mm³/m width [in.³/ft width]. Note: This choice of units is dimensionally and conceptually consistent with "W."
 C_6 = 0.125 for SI and inch pound unit dimensions and applies at midspan.
 C_7 = 0.125 for SI and inch pound unit dimensions and applies at interior supports. .07 is used when stress is being evaluated at midspan—rarely critical for relatively symmetric profiles.
 C_8 = 0.100 for SI and inch pound unit dimensions and applies at interior supports. .08 is used when stress is being evaluated at midspan.

NOTE 1—The above choice of units is unusual but makes the formulas dimensionally admissible as presented—for example, W = Newtons/mm*m and lbf/in.*ft.

NOTE 2—For derivation of f_d see 6.1.2.

NOTE 3—The Section Modulus (S) for single span shall be based on the positive Section Modulus (S_p) when the load causes positive bending. The Section Modulus (S) selection for dual, triple, and other multiple spans shall consider both the negative (S_n) and positive (S_p) Section Moduli as published by the appropriate steel deck manufacturer. The selection of Section Modulus and moment coefficient shall be consistent with the span location and bending type—for example, midspan and positive bending on a four equal span application, use 0.08 and S_p .

FIG. 3 Span Based on Stress Due to Uniform Total Load

TABLE 1 Uncoated Thickness for Listed Design Thicknesses of Steel

Design Thickness, t_d , mm [in.]	Minimum Accepted Thickness, Uncoated, 0.95 t_d , mm [in.]
0.749 [0.0295]	0.71 [0.028]
0.909 [0.0358]	0.86 [0.034]
1.204 [0.0474]	1.14 [0.045]
1.519 [0.0598]	1.44 [0.057]

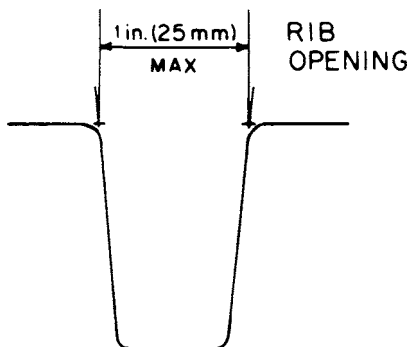

FIG. 4 Narrow Rib Deck

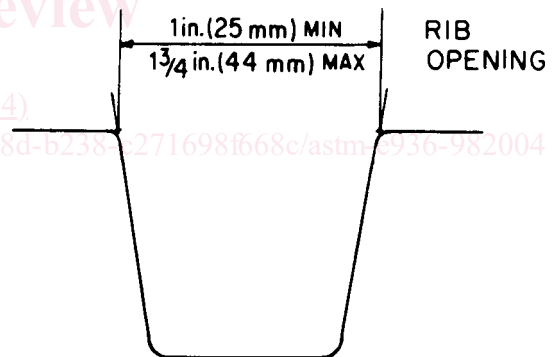

FIG. 5 Intermediate Rib Deck

than 0.6 mm thick by 200 mm wide [0.024 in. thick by 8 in. wide], bent to conform to the deck planes, should be provided. These are fastened, preferably with sheet metal screws spaced not more than 300 mm [12 in.] to both sides of the deck joints.

6.1.11 At changes in deck structural systems, discontinuous diaphragm construction, and where structural movement is to be accommodated in the framing, an expansion joint should be provided in the roofing system.

6.2 *Materials Guidelines*—The deck should conform to the following requirements:

6.2.1 *Identification*—Each deck bundle should be tagged showing design thickness and manufacturer's name.

6.2.2 *Manufactured Tolerances*—The depth of the steel deck, as manufactured, should be within a tolerance of ±1.1

may necessitate additional fastening determined in a specific manner and is the responsibility of the designer.

6.1.9 All deck openings that exceed 300 by 300 mm [12 by 12 in.] should be reinforced.

6.1.10 At changes in deck direction or plane, such as at ridges, valleys, and hips, a sheet-steel closure plate not less

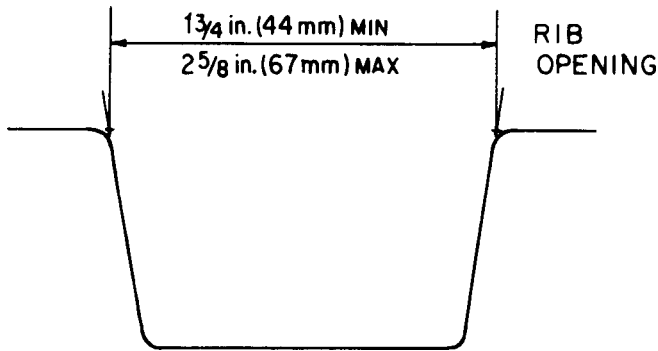
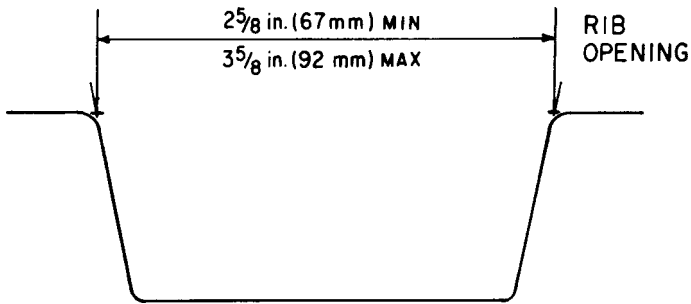
FIG. 6 Wide Rib Deck

FIG. 7 Open Rib Deck

mm [± 0.045 in.] from the design depth. The cover width of the deck sheets should be within a tolerance of $-0 + 6$ mm [-0 in. $+ 0.25$ in.] of the design width. The width of the top flange, width of bottom flange, and rib spacings should not vary more than ± 0.75 mm [± 0.030 in.] as compared to design dimensions. Inside radii should not exceed $8t$ (t = design thickness of steel deck).

6.2.3 Top Flange Surface—For assemblies in which the insulation board or vapor retarder, or both, is bonded to the steel deck by means of either a hot-melt or cold-setting adhesive, the top flange of the steel deck, after installation, shall provide a maximum contact area by means of its flat surface. The top flange surfaces must be plane without concavity or convexity exceeding 1.6 mm [$1/16$ in.]. Except at changes in direction or plane, such as at ridges, valleys, and hips, a straight edge placed across any three contact surfaces of the sheet or adjacent sheet, shall not have a gap of more than 1.6 mm [$1/16$ in.]. If this condition is exceeded, the insulation in that area should be secured with mechanical fasteners (see Section 10). The conventional center to center spacing at top flanges is 150 mm [6 in.] and 200 mm [8 in.]. The 150 -mm [6 -in.] deck module requires that at least one adhesive ribbon be placed in the center of each top flange to develop the required bond. Any deck exceeding the 150 -mm [6 -in.] module will require two adhesive ribbons on each top flange. The design width of the top flange surface should be not less than 75 mm [3 in.] with no interruption exceeding 1.6 mm [$1/16$ in.] in depth. The top flange must be capable of sustaining a 1.3 kN [300 -lb] concentrated load applied to a 75 -mm [3 -in.] diameter circle without permanent distortion or indentation exceeding 1.6 mm [$1/16$ in.] measured from a 300 -mm [12 -in.] long straight edge placed parallel to the ribs.

6.2.4 Side Lap Fastening—The side lap fastening should be capable of resisting a concentrated load of 1.3 kN [300 lb] applied downward to the top of the underlying sheet when the load is applied to a 150 - by 75 -mm area [6 by 3 -in.], long dimension parallel to the side lap and positioned 13 mm [$1/2$ in.] from the web (of the underlying sheet) nearest the side lap.

6.2.5 Deck Materials—The steel employed in the manufacture of steel roof deck should conform to the provisions of one of the following or as provided for in the latest edition of AISI Specification for the Design of Cold-Formed Steel Structural Members:

Specifications A446/A446M, A529, A570, A606, A607, and A611 (refer to 2.1).

6.2.6 Protection—All steel to be used for roof deck should be free of oil, grease, and dirt prior to shop coating. Roof deck should be galvanized coil coated or given a shop coat of primer paint. The primer coat is intended to protect the steel for only a short period of exposure in ordinary atmospheric conditions and should be considered an impermanent and provisional coating. See 9.1 for compatibility of adhesives with steel deck. High moisture or corrosive atmosphere within the building requires special consideration.

6.2.7 Nonconformance—If the installed steel deck does not conform to all of the requirements in 6.1 and 6.2, the insulation board should be fastened to the deck by means of insulation fasteners in accordance with 10.1, if acceptable to the owner's representative.

6.3 Construction Guidelines—The deck should be constructed in accordance with the following:

6.3.1 Site Storage—Steel decking should be stored off the ground with one end elevated to provide drainage and should be protected from the elements with a waterproof covering that is ventilated to avoid condensation.

6.3.1.1 Bundles in storage should be positioned so as not to cause camber, distortion, or permanent set.

6.3.2 Erection—Deck sheets should be placed in accordance with approved erection layout drawings and in conformance with the deck manufacturer's standards. Roofs having a slope of 4% ($1/2$ in. by 12 in.) should be erected beginning at the low points to assure that end laps are shingle fashion. End laps may be either butted or lapped over supports. When lapped, the recommended laps are minimum 50 mm [2 in.]. If there is less than 38 mm [$1 1/2$ in.] bearing additional fastening should be provided and the deck end load capacity should be checked. Butted end joints gap should be maximum 25 mm [1 in.] or should be covered with a deck plate.

6.3.2.1 Take care to avoid overloading the supporting structural elements when placing bundles of steel deck or other construction loads.

6.3.2.2 Construction live loads during deck erection, insulation installation, and roofing placement should be distributed to prevent damage to the previously installed components. Mechanisms used in these operations should be limited to 1.3 kN [300 lb] per wheel located not closer than 0.76 m [30 in.] apart and bearing no less than 100 -mm [4 -in.] tread width.

6.3.2.3 The deck erector should cut all openings and skew cuts in the roof deck that are shown on the deck erection drawings. Openings not shown on the deck erection drawings,

such as those required for stacks, conduits, plumbing vents, and so forth, are cut and reinforced by the trade requiring the openings.

6.3.3 Attachment of Deck to Supporting Members:

6.3.3.1 *Welding*—When welds are used that are not specifically calculated to carry design loads, they shall be made in accordance with the SDI Steel Roof Deck Design Manual. In general, these welds should be arc-spot welds (puddle welds) equivalent to at least a 13 mm [0.5-in.] diameter weld, or a fillet weld with a minimum length of 25 mm [1.0 in.]. Welds that are calculated to transfer specific design loads should be determined in accordance with AWS D1.3-81.

6.3.3.2 *Mechanical Fasteners*—Powder-actuated or pneumatically driven fasteners or screws may be used provided the type and spacing of the fasteners satisfy the design criteria (see Appendix X2.2.3).

6.3.4 Attachment of Deck Side Laps:

6.3.4.1 Welds or mechanical fasteners at side laps shall occur at all supports and penetrate all thicknesses of the metal decking to the structural member.

6.3.4.2 Screws, button punching, or welds may be used at all side lap connections between supports. Screws should be a minimum size No. 8. They may be self-drilling/self-tapping type.

6.3.5 Location of Attachments:

6.3.5.1 Each sheet should be fastened to each end support at each side of the sheet and through interior ribs so that the spacing of fasteners along supports does not exceed an average of 300 mm [12 in.] on center. At intermediate supports, fastening should occur at each side lap and once in between, but no more than an average of 380 mm [15 in.] on center maximum.

6.3.5.2 The deck is to be supported and fastened around the building perimeter unless otherwise permitted by local regulations. At a minimum, attach the side edge using the same fastener spacing that is used at interior deck side seams. For case when deck ribs are perpendicular to perimeter beam, at minimum attach deck at 300 mm [12 in.] on center. Wind uplift and diaphragm loads can require additional fasteners. Maximum attachment spacing at side lap is 1 m [36 in.] on center for all spans. Depending on project requirements, button punching, screws, or welds are acceptable. See Section 6.1.4.

6.3.6 *Diaphragm*—If deck is to serve as a diaphragm in resisting lateral loading, heavier fastenings or closer spacing of attachments, or both, may be necessary. For specific recommendations, consult deck manufacturer.

7. Vapor Retarder

7.1 *Design Guidelines*—Migration of moisture from high vapor-pressure (humidity) areas into the insulation and through to the underside of the roofing membrane may create problems in the roof system. In locations where such conditions exist, the designer should evaluate the need for a water vapor retarder (see ASHRAE Roofing Insulation Recommendations, AIA Roof System Design Manual and NRCA Energy Manual). When required, water vapor retarder design should be in accordance with the following provisions:

7.1.1 *Materials*—Any material which provides, in service, an unbroken barrier over the roof deck, or over a thin layer of insulation to limit water vapor transfer from inside the building into the roof system, as provided in 7.2.3, may be used (see Practice C755).

7.1.2 *Side and End Laps*—Side and end laps of water-vapor retarder in sheet form should be sealed as recommended by the manufacturer and have adequate overlap to provide a continuous, unbroken membrane.

7.1.3 *Penetration*—All deck penetrations and roof edges should be flashed to provide continuity of the water-vapor retarder. The effectiveness of a water-vapor retarder will be reduced if penetrations and openings are not sealed.

7.1.4 *Compatibility*—Water-vapor retarders should be compatible with adjacent materials in contact therewith and maintain its integrity as a water-vapor retarder.

7.2 *Materials Guidelines*—The water-vapor retarder should conform to the following requirements:

7.2.1 *Identification*—Containers and packages should bear the manufacturer's or supplier's name and address, product name, quantity, appropriate markings, such as UL, FM, other testing agencies, ASTM, government specifications, and so forth, and information relative to storage conditions.

7.2.2 *Flatness and Straightness*—When unrolled on a flat surface, the material should be free of fishmouths at edges and should lie flat. The lateral camber when unrolled should not exceed 13 mm [$\frac{1}{2}$ in.] in 30 m [100 ft].

7.2.3 *Permeance*—The water-vapor retarder should conform to permeance standards as follows: When tested in accordance with Test Methods E96/E96M, Procedure A, Desiccant Method at 23°C [73.4°F], the permeance should not be more than 2.87×10^{-11} SI Perms [0.50 Perms].

7.2.4 *Fire Performance*—If a fire-rated assembly is required, the fire performance of the water vapor-retarder when incorporated in a roofing system should be measured by laboratory test such as Factory Mutual Construction Materials Calorimeter, Underwriters' Laboratories Test for Fire Acceptability or other appropriate fire test procedure.

7.2.5 Compatibility with Adhesives:

7.2.5.1 When a water-vapor retarder is installed with a solvent-based adhesive, the adhesive and water-vapor retarder should be furnished by the same manufacturer.

7.2.5.2 Plastic water-vapor retarders should not be installed using hot bitumen, nor should hot bitumen be used to secure insulation board to plastic water-vapor retarders.

7.3 *Construction Guidelines*—The water-vapor retarder should be handled and installed in accordance with the following:

7.3.1 *Site Storage*—Water-vapor retarders should be stored under cover, off the ground, and be temperature controlled where necessary. Any covering shall include ventilation and shall protect against drippage from condensation.

7.3.2 *Construction Live Loads*—Any construction live loads during erection and roofing should be distributed to prevent damage to the previously installed components.

7.3.3 *Deck Preparation*—The deck surface should be clean and dry during application of the water-vapor retarder.

7.3.4 *Side and End Laps*—When sheet or roll materials are used, minimum 50-mm [2-in.] wide side laps should be formed on the steel-deck top flange and sealed with the adhesive recommended by the manufacturer. End laps should be a minimum of 100 mm [4 in.] in width and sealed with the adhesive recommended by the manufacturer.

7.3.5 *Tears, Punctures, and Penetration*—All tears, punctures, and penetrations, except punctures necessitated by mechanical fasteners, should be patched with water-vapor retarder material, using the manufacturer’s recommended adhesive, to maintain the integrity of the water-vapor retarder.

7.3.5.1 When securing insulation over vapor retarders with mechanical fasteners, the permeance may be affected.

7.3.6 *Plastic Vapor Retarders:*

NOTE 6—Plastic water-vapor retarders may be damaged when in contact with hot bitumen.

7.3.7 *Securement*—Vapor retarders shall be secured to the steel deck in accordance with the approved specifications.

7.3.8 *Completion of Roofing System*—The vapor retarder shall be covered by the insulation and roofing membrane at the end of each working day. If final surfacing is to be delayed, provide a glaze coat, when required.

8. Preformed Roof Insulation

8.1 *Design Guidelines*—Insulation should provide a thermal resistance required to maintain an interior environment compatible with occupancy, internal heat development projected for the building construction, and energy conservation. The designer should determine the type and thickness required to provide the desired thermal conductance value. Thermal resistance, *R*, may vary from manufacturers’ published data due to aging and other factors. Manufacturers should be consulted for in service (long term) thermal conductance. Additionally refer to the NRCA/MRCA joint bulletin “In Service R-values (ISR) for Polyisocyanurate and Polyurethane Roof Insulation Boards.” Some insulations accelerate the corrosion of roof decks and promote blistering of roof membrane in the presence of moisture, or both. Insulation manufacturers should be consulted to confirm material compatibility and proper installation within roof systems. See Specification C1126, Section 11.3.

8.1.1 *Materials*—Roof insulation shall be of the preformed-board type and may be one or a combination of the following (latest edition):

Wood Fiber	Specification C208
Rigid Foamed Phenolic	Specification C1126
Expanded Perlite	Specification C728
Mineral Fiber	Specification C726
Rigid Polystyrene	Specification C578
Rigid Polyisocyanurate	Specification C1289
Rigid Polyurethane	Specification C1013
Cellular Glass	Specification C552

8.1.2 *Fire Hazard*—Insulations, when combined with other roofing components, may exhibit a potential fire-spreading condition. Fire protective measures should be incorporated and materials selected to limit a fire-spreading condition and to provide the desired fire endurance.

8.1.3 *Mechanical Fastening*—For single-layer applications, resilient insulations may require mechanical fasteners that

permit vertical movement to avoid puncturing of roof covering under concentrated load (see section 9.2.4).

8.1.3.1 *Perimeter Fastening*—Insulation should also be fastened mechanically to the steel deck in a band not less than 1200 mm [4 ft] wide along all exterior walls or in a greater width as otherwise specified by the authority having jurisdiction.

8.1.3.2 *Mechanically Fastened Roof Systems*—Insulation fasteners may be used as sole means of securing insulation to the steel decking.

8.2 *Materials Guidelines*—The quality and performance of all roof insulation should be confirmed by specific test procedures, where applicable, or by established recognized agencies.

8.2.1 *Identification*—Packaged insulation should bear the manufacturer’s or supplier’s name and address, product name, quantity, appropriate performance and specification markings, type of board, thickness, R or C value, and where applicable, appropriate safety warnings.

8.2.2 *Shape Stability*—Insulation units should not curl or bow, when properly adhered or fastened, more than 3 mm [$\frac{1}{8}$ in.] in 1200 mm [4 ft] when measured by placing a straightedge diagonally across a 1200-mm board and should maintain their original dimensions within the manufacturer’s tolerance for length, width, and thickness. Certain proprietary insulations in which the manufacturer states that deformation during installation may occur, should be warranted to have no effect on the adhesion of the board or the performance of the built-up roof when installed in accordance with manufacturer’s instructions. See Practice C550 and Methods C209.

8.2.3 *Thermal Performance*—Thermal conductance, *C*, or resistance, *R*, stated in markings on the product or package should be determined in accordance with Test Method C177, C518 or C236, provided Test Method C518 shows comparability to absolute values in accordance with Test Method C177.

8.2.4 *Fire Performance*—If an assembly resistant to internal fire spread is desired, the fire performance of the insulation, when incorporated in a roofing system, should be measured by a laboratory test such as the Factory Mutual Construction Materials Calorimeter, Approval Standard 4450 Class I Steel Deck Roofs, or Underwriters Laboratories Fire Test of Roof Deck Constructions, UL1256, or other appropriate fire test procedure.

8.2.5 *Compatibility with Adhesives:*

8.2.5.1 The compatibility of hot or cold adhesives with certain foamed plastic insulations should be reviewed or verified prior to use.

8.3 *Construction Guideline*—The insulation should be handled and installed in accordance with the following:

8.3.1 *Site Storage*—Insulation units should be stored off the ground and under cover. Covering should include provisions for ventilation to resist condensation and protection against drippage.

8.3.2 *Construction Live Loads*—Any construction live loads during erection and roofing should be distributed to prevent damage to the previously installed components.

8.3.3 *Deck Preparation*—Deck surface should be clean and dry during application of the insulation. Wood nailers should

be installed at roof edges adjoining all eaves and roof projections and should be secured to the building structure to provide a stop at least the same thickness as the insulation. Wood nailers should be treated with a water-borne salt preservative approved by the American Wood Preserver's Institute. Oil-based preservatives, such as creosote, are not acceptable as they are not compatible with asphalt roofing components.

8.3.4 *Application and Installation*—The insulation boards should be applied and installed as follows:

8.3.4.1 Insulation boards should be butted together. All joints over 6 mm [$\frac{1}{4}$ in.] wide should be filled with insulation.

8.3.4.2 The units of insulation should be applied in accordance with the approved construction specifications. Insulation joints parallel to ribs of steel deck should be placed over solid bearing. Where bearing does not occur, cover the open rib with a strip of suitable support material, or cut the insulation board as required.

8.3.4.3 Insulation installed in multiple layers should have the joints offset, preferably one-half board [minimum 150 mm (6 in.)], between layers. The thickness and type of the first layer should be that approved by the authority having jurisdiction.

(1) Attachment of the bottom layer should be by mechanical fasteners.

(2) Attachment of the second and subsequent layers should be by solid mopping of asphalt (use Specification **D312**), or by mechanically fastening to the deck.

8.3.4.4 *Perimeter Fastening*—The first layer of insulation must be secured to the steel deck with mechanical fasteners in a band of sufficient width around the entire perimeter of the roof to satisfy the requirements of the authority having jurisdiction.

(1) Mechanical fasteners may be used as the sole means of securing insulation to the deck.

8.3.4.5 Where a vapor retarder is used, the insulation should be vented in accordance with designers recommendations (see Appendix **X2.3**).

8.3.5 *Completion of Roof System*—The insulation should be covered by the completed roofing membrane at the end of each working day, except that the final surfacing may be delayed provided a glaze coat is installed, if required. Some systems need not be glazed. Consult the membrane manufacturer.

9. Insulation Fasteners

9.1 *Design Guidelines*—Fasteners used to secure insulation shall be designed to develop a permanent attachment with the steel deck. The type of fastener assembly is the designer's option and must conform to the standards established by the authority having jurisdiction.

9.1.1 *Materials*—The fasteners may conform to the Factory Mutual Approval Guide, latest edition. The fasteners should be of steel and be a piercing type. If the fastener head is not of sufficient area, a load distribution plate or disc should be required.

9.1.2 *Physical Properties*—Fasteners should conform to the following:

9.1.2.1 All fasteners should be capable of being installed without damage resulting in loss of holding strength.

9.1.2.2 The fastener-shank length should be adequate to engage the deck and to accommodate the thickness of the roof insulation.

9.1.2.3 When used to secure resilient-type insulation board, the fastener should be capable of limited vertical movement to avoid puncturing the roof covering.

NOTE 7—The hardness of the steel deck should be considered when selecting the insulation fasteners.

9.2 *Materials Guidelines*—The insulation fasteners should conform to the following requirements:

9.2.1 *Identification*—Containers shall bear the manufacturer's or supplier's name and address, product name, quantity, size, and appropriate performance specification marking, and so forth.

9.2.2 *Corrosion Resistance*—When tested 48 h in accordance with Method **B117**, the fastener may exhibit minimal traces of rust spots.

9.2.3 *Length*—The length of the fastener should be sufficient to engage the deck and to accommodate the thickness of the roof insulation. Stiffening grooves in steel deck must be taken into consideration when selecting the length.

9.2.4 *Vertical Movement*—When used to secure resilient-type insulation board, the fastener should be capable of limited vertical movement to avoid puncturing the roof covering (see section 8.1.4).

9.3 *Construction Guidelines*—The insulation fasteners should be handled and installed in accordance with the following:

9.3.1 *Protection from the Elements*—Insulation fasteners should be stored off the ground and under cover.

9.3.2 *Installation:*

9.3.2.1 Fasteners should be driven using the hammers, mallets, or mechanical devices recommended by the manufacturer or supplier.

9.3.2.2 Fasteners may be used as the sole means of securing insulation board to steel deck. Fasteners should be used to secure all insulation boards in a band of sufficient width around the entire perimeter of the roof to satisfy the requirements of the authority having jurisdiction.

9.3.2.3 Mechanical fasteners are most effective when they engage the top flange of the steel deck. It may be necessary to snap a chalk line on the insulation to aid in locating the flanges.

9.3.2.4 The fastener used should be long enough to penetrate the insulation, engage, and lock into the deck.

9.3.2.5 The minimum number and spacing of insulation fasteners should be as required by the Factory Mutual Approval Guide.

10. Built-Up Bituminous Roofing

10.1 *Design Guidelines*—The built-up roof covering should consist of plies of roofing sheets and an appropriate waterproofing adhesive to provide a weather-resistant covering for the roof assembly. The roof covering should not be subject to standing water, and the roof assembly should be sloped to provide drainage (see section 5.4). Delayed drainage is not recommended. If required by codes, the designer should make