



Standard Test Method for Measuring Baseball Bat Performance Factor¹

This standard is issued under the fixed designation F 1881; the number immediately following the designation indicates the year of original adoption or, in the case of revision, the year of last revision. A number in parentheses indicates the year of last approval. A superscript epsilon (ϵ) indicates an editorial change since the last revision or reapproval.

1. Scope

1.1 This specification defines a method for determining bat performance by measuring the bat-ball coefficient of restitution (BBCOR), deriving the bat performance factor (BPF), and calculating batted-ball speed (BBS). It is applicable to baseball bats of any construction or material. The method provides a quantitative measure of bat dynamic performance that may be used for comparison purposes.

1.2 The BBCOR, BPF, and BBS are each calculated from measurements taken in the laboratory on test equipment meeting the requirements defined in this test method.

1.3 The values stated in inch-pound units are to be regarded as the standard. The values given in parentheses are for information only.

1.4 *This standard does not purport to address all the safety concerns, if any, associated with its use. It is the responsibility of the user of this standard to establish appropriate safety and health practices and to determine the applicability of regulatory limitations prior to use.*

2. Referenced Documents

2.1 ASTM Standards:²

F 1887 Test Method for Measuring the Coefficient of Restitution (COR) of Baseballs and Softballs

F 1888 Test Method for Compression-Displacement of Baseballs and Softballs

3. Terminology

3.1 Definitions of Terms Specific to This Standard:

3.1.1 *balance point, n*—distance to the center of mass of a bat when measured from the distal end of the bat knob.

3.1.2 *bat-ball coefficient of restitution (BBCOR), n*—COR of a specific ball colliding with a bat as defined in this test method. See *coefficient of restitution (COR)*.

3.1.3 *bat performance factor (BPF), n*—ratio of BBCOR to ball COR in accordance with this test method.

3.1.4 *center of percussion (COP), n*—also known as the *center of oscillation*, length of a simple pendulum with the same period as a physical pendulum, as in a bat oscillating on a pivot. Forces and impacts at this location will not induce axial reactions at the pivot point.

3.1.5 *coefficient of restitution (COR), n*—measure of impact efficiency calculated as the relative speed of the objects after impact divided by the relative speed of the objects before impact.

3.1.6 *cycle, n*—one complete performance of the oscillation of the bat, specifically, one full swing of the bat.

3.1.7 *moment of inertia (MOI), n*—measure of mass distribution relative to an axis of rotation. It is the product of the mass multiplied by the square of the distance to the mass, summed over the entire bat.

3.1.8 *period, n*—time required for a pendulum to oscillate through one complete cycle.

4. Significance and Use

4.1 This test method offers a laboratory means to compare the performance of a baseball bat.

4.2 Use of this test method can provide sports governing bodies a means to compare calculated batted-ball speed and other physical properties of the bat for the purposes of controlling the game.

5. Apparatus

5.1 Bat COP Test Apparatus:

5.1.1 *Ruler*, suitable for measuring lengths up to 42 in. (1067 mm) to the nearest 0.031 in. (0.79 mm).

5.1.2 *Weight Scale*, suitable for measuring weight up to 48 oz (1360 g) to the nearest 0.0035 oz (0.1 g).

5.1.3 *Electronic Timer*, suitable device for measuring time to the nearest 1 μ s (0.000001 s).

5.1.4 *MOI Stand*—A frame with a pivoting bat collar-clamp large enough to allow a bat held in a vertical position to swing freely (see Fig. 1).

5.1.5 *Bat Collar-Clamp*—A part of the MOI stand that allows quick, accurate mounting of the bat without a variable MOI effect due to the clamp with a maximum MOI of 4 oz-in.² (0.8 kg-cm²) measured about the bat pivot location. A light weight clamp or collar that can hold the weight of a bat and

¹ This test method is under the jurisdiction of ASTM Committee F08 on Sports Equipment and Facilities and is the direct responsibility of Subcommittee F08.26 on Baseball and Softball Equipment.

Current edition approved July 1, 2004. Published July 2004. Originally approved in 1998. Last previous edition approved in 1998 as F 1881 – 98.

² For referenced ASTM standards, visit the ASTM website, www.astm.org, or contact ASTM Customer Service at service@astm.org. For *Annual Book of ASTM Standards* volume information, refer to the standard's Document Summary page on the ASTM website.

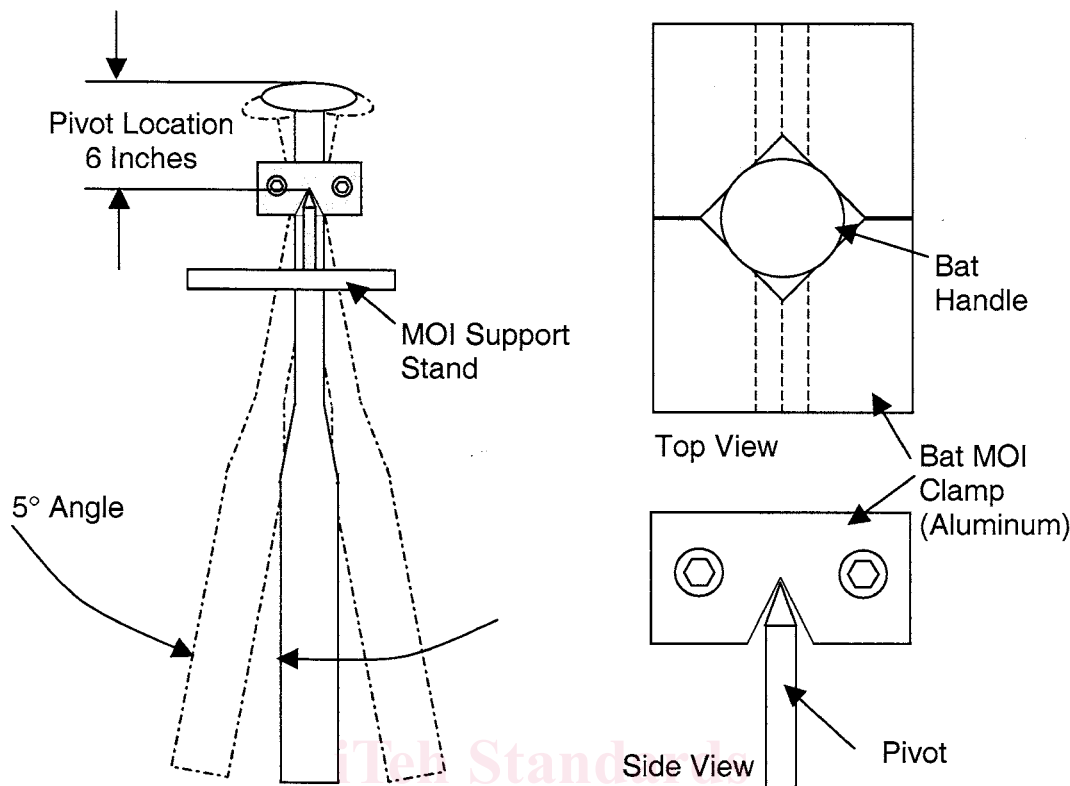

FIG. 1 MOI Fixture

provide a fixed pivot location. Collar shall be rotationally balanced (see Fig. 1).

5.2 *Test Balls*—Official balls approved for play and tested in accordance with the following procedures.

5.2.1 *Compression*—300 to 375 lb at 0.25-in. deflection (1135 to 1668 N at 6.4 mm deflection). Compression values determined in accordance with Test Method F 1888. Balls to be labeled with compression value.

5.2.2 *Weight*—5.00 to 5.25 oz (142 to 149 g), balls to be labeled with weight value.

5.2.3 *Size*—9.00 to 9.50-in. circumference (228.6 to 241.3 mm), balls to be labeled with size value.

5.2.4 *COR*—0.525 to 0.555, balls to be labeled with COR and test speed in ft/s.

5.3 *Bat-Ball COR Test Apparatus:*

5.3.1 *Ball Cannon*—A device capable of shooting a ball at a speed of 88 ft/s. The ball shall not have a spin rate in excess of 10 rpm. Typical pitching machines cannot yield the aiming accuracy required by this test method. Cannon exhaust air must not cause motion of the bat in the absence of an impact. The cannon shall not blow out a match located in the impact location when it is dry-fired (fired without a ball). The ball cannon can be any distance from impact location, as long as it can meet the ball aim requirements and provide six valid impacts in twelve shots or less.

5.3.2 *Bat Speed Gate*—A light trap, device, or an equivalent, capable of measuring an edge traveling at speeds in excess of 88 ft/s (26.8 m/s) with an accuracy of 0.5 ft/s or better (0.2 m/s). The first sensor shall trigger when the bat rotates no less than 15° and no more than 20° from its start position. It is

suggested the second trigger be 3 in. (76.2 mm) away from the first and must not be any further than 3.6 in. (91.4 mm) away on a 6-in. (15.24-cm) radius.

5.3.3 *Ball Speed Gate*—A light trap, device, or an equivalent, capable of measuring a sphere traveling at speeds in excess of 88 ft/s (26.8 m/s) with an accuracy of 0.5 ft/s or better (0.2 m/s). The device shall measure across a length of no less than half the ball diameter to avoid centering error. For example, when testing baseballs, the device shall sense an object across a 2.0-in. (50.8-mm) line. The first sensor shall trigger when the ball is no more than 12 in. (30.5 cm) from the bat surface. The second sensor shall trigger between 3.6 in. (91.4 mm) and 8 in. (203.2 mm) from the first sensor.

5.3.4 *Bat Pivot Support*—A turntable, rotating in the horizontal plane, with clamps to support and align the bat in the path of the ball. The clamp surfaces shall be a 45° Vee clamp with a radius no greater than 2.0 in. (50.8 mm). The rotating clamp and shaft assembly shall not weigh more than 6 lb (2.7 kg) and shall spin freely via ball bearings (see Fig. 2). The polar MOI for the clamp turntable assembly shall not exceed 192 oz/in.² (35 117 g/cm²). The actual MOI of the clamp turntable assembly shall be determined and used in the performance calculations.

6. Calibration and Standardization

6.1 *Ball Speed Gate*—The distances between the sensors of the speed gates must be known and recorded to the stated tolerances. The accuracy of the timers used in the velocity sensors must be adequate to provide the stated velocity