

# ETSI TS 101 548 V1.1.1 (2014-09)



## Access, Terminals, Transmission and Multiplexing (ATTM); European Requirements for Reverse Powering of Remote Access Equipment

*iTeh STANDARDS PREVIEW*  
*(standards.iteh.ai)*  
*Full standards catalog: <https://standards.iteh.ai/catalog/standards/sist/4fc0c47d-5bb8-4d56-b80f-8c62d23d079b/etsi-101-548-v1-1-1-2014-09>*

---

Reference

DTS/ATTM-06100-1

---

Keywords

VDSL2

**ETSI**

650 Route des Lucioles  
F-06921 Sophia Antipolis Cedex - FRANCE

Tel.: +33 4 92 94 42 00 Fax: +33 4 93 65 47 16

Siret N° 348 623 562 00017 - NAF 742 C  
Association à but non lucratif enregistrée à la  
Sous-Préfecture de Grasse (06) N° 7803/88

---

**Important notice**

The present document can be downloaded from:

<http://www.etsi.org>

The present document may be made available in electronic versions and/or in print. The content of any electronic and/or print versions of the present document shall not be modified without the prior written authorization of ETSI. In case of any existing or perceived difference in contents between such versions and/or in print, the only prevailing document is the print of the Portable Document Format (PDF) version kept on a specific network drive within ETSI Secretariat.

Users of the present document should be aware that the document may be subject to revision or change of status. Information on the current status of this and other ETSI documents is available at

<http://portal.etsi.org/tb/status/status.asp>

If you find errors in the present document, please send your comment to one of the following services:

[http://portal.etsi.org/chaircor/ETSI\\_support.asp](http://portal.etsi.org/chaircor/ETSI_support.asp)

---

**Copyright Notification**

No part may be reproduced or utilized in any form or by any means, electronic or mechanical, including photocopying and microfilm except as authorized by written permission of ETSI.

The content of the PDF version shall not be modified without the written authorization of ETSI.

The copyright and the foregoing restriction extend to reproduction in all media.

© European Telecommunications Standards Institute 2014.

All rights reserved.

**DECT™**, **PLUGTESTS™**, **UMTS™** and the ETSI logo are Trade Marks of ETSI registered for the benefit of its Members. **3GPP™** and **LTE™** are Trade Marks of ETSI registered for the benefit of its Members and of the 3GPP Organizational Partners.

**GSM®** and the GSM logo are Trade Marks registered and owned by the GSM Association.

# Contents

Intellectual Property Rights .....	4
Foreword.....	4
Modal verbs terminology.....	4
Introduction .....	4
1 Scope .....	5
2 References .....	5
2.1 Normative references .....	5
2.2 Informative references.....	5
3 Definitions, symbols and abbreviations .....	6
3.1 Definitions .....	6
3.2 Symbols.....	6
3.3 Abbreviations .....	6
4 Introduction to Reverse Power Feed .....	8
4.1 Introduction .....	8
5 Reverse Power Feed Architecture .....	9
5.1 Introduction .....	9
5.2 Reverse Power Feed and POTS Co-Existence .....	9
5.2.1 Background.....	9
5.2.2 POTS Adapters .....	10
5.2.2.1 POTS Adapter - E (POTSA-E).....	10
5.2.2.2 POTS Adapter - C (POTSA-C).....	10
5.2.2.3 POTS Adapter - D (POTSA-D).....	10
5.3 Reverse Power Feed Architecture without POTS on the same pair (RPFA-NOP).....	11
5.4 Reverse Power Feed Architecture with Baseband POTS from the Exchange (RPFA-EXP).....	12
5.5 Reverse Power Feed Architecture with Baseband POTS from the Exchange Sharing the in-premises Wiring (RPFA-EXPSW) .....	14
5.6 Reverse Power Feed Architecture with Derived POTS (RPFA-DRP) .....	15
5.7 Reverse Power Feed Architecture with Derived POTS Sharing the in-premises Wiring (RPFA-DRPSW) ....	16
6 Reverse Power Feed Start-Up Protocol.....	17
6.1 Introduction .....	17
6.2 Communications-based Start-up (CBSU) Protocol .....	18
6.3 CBSU Protocol Specific Transmission Parameters.....	20
7 Reverse Power Feed Power Supply Characteristics .....	21
7.1 RPF Range Options and Classes .....	21
7.2 RPF Safety Requirements .....	24
7.2.1 Background.....	24
7.2.2 Unintended consequences.....	25
7.3 Electrical reference model.....	25
7.4 Zero touch DPU .....	26
<b>Annex A (informative): Reverse power backup systems .....</b>	<b>27</b>
A.1 Case 1 battery backup in the CPE .....	27
A.2 Case 2 battery backup in the DPU and CPE.....	27
<b>Annex B (normative): General POTS requirements .....</b>	<b>28</b>
<b>Annex C (informative): Bibliography.....</b>	<b>29</b>
History .....	30

---

## Intellectual Property Rights

IPRs essential or potentially essential to the present document may have been declared to ETSI. The information pertaining to these essential IPRs, if any, is publicly available for **ETSI members and non-members**, and can be found in ETSI SR 000 314: *"Intellectual Property Rights (IPRs); Essential, or potentially Essential, IPRs notified to ETSI in respect of ETSI standards"*, which is available from the ETSI Secretariat. Latest updates are available on the ETSI Web server (<http://ipr.etsi.org>).

Pursuant to the ETSI IPR Policy, no investigation, including IPR searches, has been carried out by ETSI. No guarantee can be given as to the existence of other IPRs not referenced in ETSI SR 000 314 (or the updates on the ETSI Web server) which are, or may be, or may become, essential to the present document.

---

## Foreword

This Technical Specification (TS) has been produced by ETSI Technical Committee Access, Terminals, Transmission and Multiplexing (ATTM).

---

## Modal verbs terminology

In the present document "shall", "shall not", "should", "should not", "may", "may not", "need", "need not", "will", "will not", "can" and "cannot" are to be interpreted as described in clause 3.2 of the [ETSI Drafting Rules](#) (Verbal forms for the expression of provisions).

"must" and "must not" are **NOT** allowed in ETSI deliverables except when used in direct citation.

---

## Introduction

As various Operators consider the deployment of fibre-fed remote nodes that contain xDSL DSLAM equipment, it is necessary to consider the means of powering such remotely located equipment. One such method, known as "reverse power feed", transmits the power from the customer premises to the fibre-fed remote node using the distribution-side copper network. The present document defines a reverse power feed transmission standard which allows Operators to source suitably compliant equipment for inclusion in their networks. The reverse power feed methodology can be used to power a remote node hosting any metallic transmission system (e.g. FAST [i.6], VDSL2 [i.7], etc.).

---

# 1 Scope

The present document defines architectures for reverse powering of remote network nodes from multiple CPEs. The architectures describe how to combine reverse power feed with POTS and data transmission. Options for combining reverse powering with battery backup are also described. The present document identifies requirements for POTS signalling translation when operated over reverse power feed. Start-up protocols are defined that will ensure safe connection of reverse powered systems. Management requirements for reverse power feed and power combining within the remote network node are specified.

---

## 2 References

References are either specific (identified by date of publication and/or edition number or version number) or non-specific. For specific references, only the cited version applies. For non-specific references, the latest version of the reference document (including any amendments) applies.

Referenced documents which are not found to be publicly available in the expected location might be found at <http://docbox.etsi.org/Reference>.

NOTE: While any hyperlinks included in this clause were valid at the time of publication, ETSI cannot guarantee their long term validity.

### 2.1 Normative references

The following referenced documents are necessary for the application of the present document.

- [1] ETSI ES 202 971: "Access and Terminals (AT); Public Switched Telephone Network (PSTN); Harmonized specification of physical and electrical characteristics of a 2-wire analogue interface for short line interface".
- [2] CENELEC EN 60950-1: "Information Technology Equipment - Safety Part 1: General requirements (IEC 60950-1:2005 + Cor.:2006 + A1:2009, modified)".
- [3] ETSI ES 203 021: "Access and Terminals (AT); Harmonized basic attachment requirements for Terminals for connection to analogue interfaces of the Telephone Networks; Update of the technical contents of TBR 021, EN 301 437, TBR 015, TBR 017".
- [4] Recommendation ITU-T G.994.1: "Handshake procedures for digital subscriber line transceivers".

### 2.2 Informative references

The following referenced documents are not necessary for the application of the present document but they assist the user with regard to a particular subject area.

- [i.1] IEEE 802.3: "LAN/MAN CSMA/CD (Ethernet) Access Method".

NOTE: Available at <http://standards.ieee.org/getieee802/802.3.html>.

- [i.2] NICC ND 1645 (V1.1.2) (2011-06): "NGA Telephony; Architecture and requirements".

NOTE: Available at <http://www.niccstandards.org.uk/files/current/ND1645v1.1.2.pdf?type=pdf>.

- [i.3] ETSI TS 101 952-1: "Access network xDSL splitters for European deployment; Part 1: generic specification of xDSL over POTS splitters".
- [i.4] Recommendation ITU-T G.993.2: "Very high speed digital subscriber line transceivers 2 (VDSL2)".
- [i.5] Recommendation ITU-T G.993.2 Amendment 5: "Short reach VDSL2 with reduced power and enhanced data rate".

- [i.6] Recommendation ITU-T G.9700 (04/14): "Fast access to subscriber terminals (FAST) - Power spectral density specification".
- [i.7] ETSI TS 101 271 (V1.2.1): "Access, Terminals, Transmission and Multiplexing (ATTM); Access transmission systems on metallic access cables; Very High Speed digital subscriber line system (VDSL2) [Recommendation ITU-T G.993.2 modified]".

## 3 Definitions, symbols and abbreviations

### 3.1 Definitions

For the purposes of the present document, the following terms and definitions apply:

**power splitter:** device that performs a frequency splitting/combining function between the services being carried (which can include POTS and xDSL based services) and the injected DC electrical power

**service splitter:** low pass filter that separates baseband POTS from xDSL frequencies

NOTE: The relevant specifications for the service splitter can be found in ETSI TS 101 952-1 [i.3].

### 3.2 Symbols

For the purposes of the present document, the following symbols apply:

R	2-wire analogue presented interface
U-R	Reference point at CPE containing both DC power and service data
U-R2	Reference point at CPE containing the filtered service data
U-R2P	Reference point at CPE containing the injected DC power
U-R2S	Reference point at CPE containing the baseband POTS and the converted POTS signalling
U-O	Reference point at DPU containing both DC power and service data
U-O2	Reference point at DPU containing the filtered service data
U-O2O	Reference point at DPU containing the baseband POTS and the converted POTS signalling
U-O2P	Reference point at DPU containing the extracted DC power

### 3.3 Abbreviations

For the purposes of the present document, the following abbreviations apply:

4PPoE	4-Pair Power over Ethernet
ACT	Active
ATA	Analogue Telephone Adapter
BAT	Battery
CBSU	Communications based Start-Up protocol
CO	Central Office
CP	Customer Premises
CPE	Customer Premises Equipment
CPE ME	CPE's Management Entity
DBPSK	Differential Binary Phase Shift Keying
DC	Direct Current
DN	Distribution Network
DP	Distribution Point
DPU	Distribution Point Unit
DPU ME	DPU's Management Entity
DSL	Digital Subscriber Line
FTTdp	Fibre To The distribution point
FTTP	Fibre To The Premises

FTU FAST Transceiver Unit

NOTE: See Recommendation ITU-T G.9700 [i.6].

FTU-O	FTU at the DPU
FTU-R	FTU at the remote site
GPON	Gigabit Passive Optical Network
HON	Higher Order Node
LPF	Low Pass Filter
LR	Long Range
ME	Management Entity
NMS	Network Management System
NT	Network Termination
NTE	Network Termination Equipment
NTU	Network Terminating Unit
OAM	Operations And Maintenance
OLT	Optical Line Termination
ONU	Optical Network Unit
PD	Powered Device
PDU	Power Distribution Unit
PE	Power Extraction
PHY	Physical (layer)
PME-C	CPE's Power Management Entity
PME-D	DPU's Power Management Entity
PMT	Power Management Transceiver
PoDL	Power over Data Line
POTS	Plain Old Telephony Service
PS	Power Splitter
PSE	Power Sourcing Equipment
PSU	Power Supply Unit/Combiner
PWD	PoWered
RDY	Ready
RFT	Remote Feed Telecommunication
RPCE	Reverse Power Control Entity
RPD	Remote Powered Device
RPF	Reverse Power Feed
RPFA-DRP	Reverse Power Feed Architecture - Derived POTS
RPFA-DRPSW	Reverse Power Feed Architecture - Derived POTS Sharing in-premises Wiring
RPFA-EXP	Reverse Power Feed Architecture - Exchange POTS
RPFA-EXPSW	Reverse Power Feed Architecture - Exchange POTS Sharing in-premises Wiring
RPFA-NOP	Reverse Power Feed Architecture - No POTS
SELV	Safety Extra Low Voltage
SG	Service Gateway
SR	Short Range
SS	Service Splitter
SU	Service Unit
TNV	Telecommunication Network Voltage
VA	Volt Ampere
VDSL	Very high speed Digital Subscriber Line
VoIP	Voice over Internet Protocol
VTU	VDSL2 Transceiver Unit

NOTE: See Recommendation ITU-T G.993.2 [i.4].

VTU-O	VTU at the ONU
VTU-R	VTU at the remote site
xDSL	Unspecified DSL variant
xTU-O	FTU-O or VTU-O
xTU-R	FTU-R or VTU-R



## 4 Introduction to Reverse Power Feed

### 4.1 Introduction

The basic architecture of a fibre-fed remote node with reverse power feed is shown below in Figure 1.

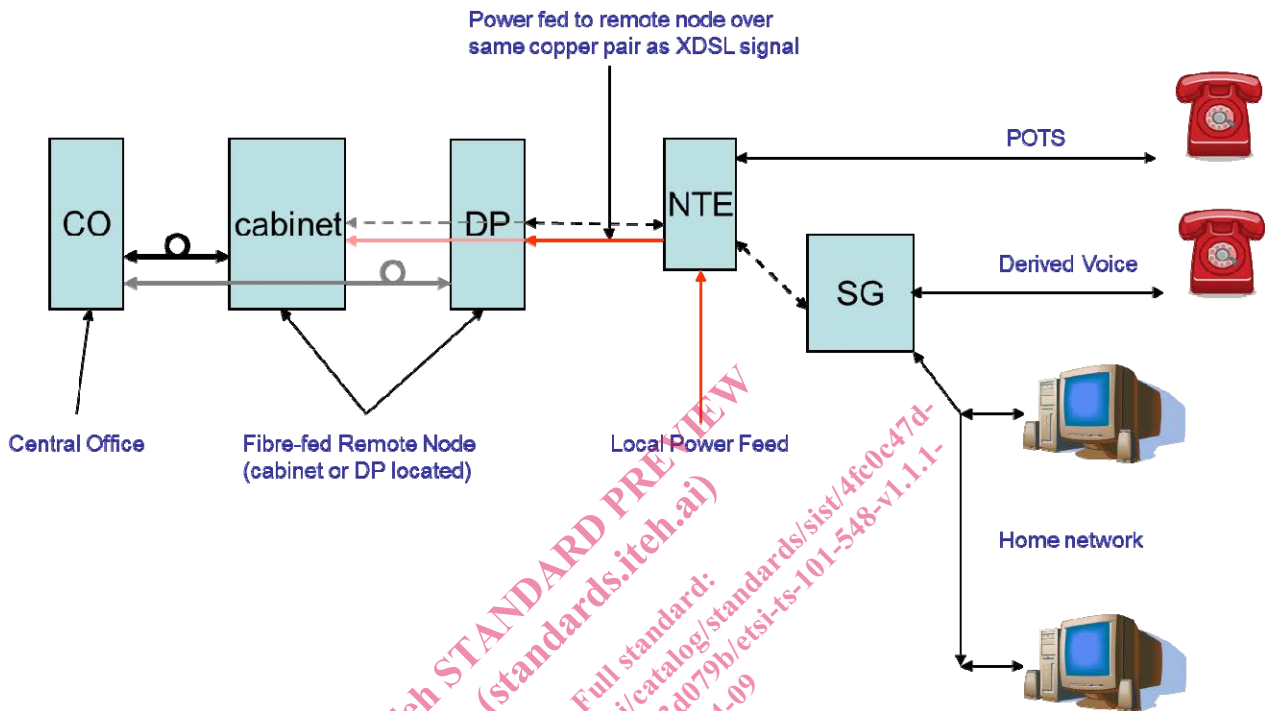

**Figure 1: Generic Fibre-fed Remote Node Architecture with reverse power feed**

Figure 1 shows power being injected at the NTE from a local power source (located within the home and/or building) which traverses the local loop to power a fibre-fed remote node which can be located at either the distribution point (DP) or cabinet using the same copper pair cable that is used to transmit the xDSL to/from the home/fibre-fed remote node. A metallic POTS service is shown at the NTE. Voice services can also be implemented as a derived service from the service gateway (SG).

An issue with regards to reverse powered fibre-fed nodes is that of who or what is responsible for the powering of common circuitry contained within the node. It is easy to envisage that an individual user should be responsible for the powering of the remote line terminating/driver electronics corresponding to his particular circuit. However, it is not so easy to determine who or what is responsible for powering of say the ONU that terminates the fibre link.

There may be occasions where only a single user is providing power to the remote node but this may not be sufficient to power all of the remote node electronics for proper operation. Also, there may be occasions where say a GPON feed requests a response from the ONU (for ranging or management purposes) when no users are currently connected and providing electrical power.

It is recognized that one single (i.e. generic) specification cannot consider all possible architectural variants, therefore the present document has been organized as a series of architecture options and equipment shall adhere to one or more of these options.



## 5 Reverse Power Feed Architecture

### 5.1 Introduction

There shall be compatibility with other architectures such as forwards powering of remote equipment from the CO or the provision of local mains powering.

Service Providers may provide options for power back-up capability at the remote node and/or the customer premises. It shall be possible to combine these power-feed options, for example when there is not enough power to operate a remote node by reverse powering from a single customer alone. Under such circumstances it shall be possible to augment this power with forwards power from the CO or local mains derived power.

Reverse powering shall have a power splitter (located at the customer premises and another at the remote node) to enable power to be inserted at the customer end of a link and extracted at the remote node. The power splitter performs a frequency splitting and combining function between the services being carried (which can include POTS and xDSL based services) and the injected DC electrical power. The power splitter shall have an upper frequency limit for powering of 300 Hz. In the case of POTS services being carried over the same metallic loop, and considering the emergence of wideband POTS services for high quality voice, the cut-over frequency of the reverse power feed power splitter should be in the order of 10 Hz or less.

Within the remote node, if it operates with multiple power-fed lines then there shall be a power extraction and combiner unit. The purpose of this unit is to combine the multiple power feed input to produce a single power source output. A fair power-sharing algorithm shall exist where the power load is fairly shared amongst the input power sources.

The technical specifications in the present document shall apply to each architecture described below as one of the five options shown in Table 1.

**Table 1: Architecture Options for Reverse Power Feed**

Option	Name	Description
1	RPFA-NOP	Reverse Power Feed Architecture - No POTS
2	RPFA-EXP	Reverse Power Feed Architecture - Exchange POTS
3	RPFA-EXPSW	Reverse Power Feed Architecture - Exchange POTS Sharing in-premises Wiring
4	RPFA-DRP	Reverse Power Feed Architecture - Derived POTS
5	RPFA-DRPSW	Reverse Power Feed Architecture - Derived POTS Sharing in-premises Wiring

### 5.2 Reverse Power Feed and POTS Co-Existence

#### 5.2.1 Background

Table 1, option 2 to option 5 involve reverse power feed co-existing with POTS - whether this is exchange based POTS (RPFA-EXP, RPFA-EXPSW) or derived POTS (RPFA-DRP, RPFA-DRPSW).

When a POTS service is present on the same wires as reverse power feed (option 2, option 3 and option 5) the POTS DC signalling/low frequency signalling will be translated so that it uses another part of the baseband spectrum, but the basic analogue voice signal remains essentially untouched. At the CPE, the signalling is restored and POTS is presented as normal.

When POTS is provided by derived voice service (option 4 and option 5), low power (L2) modes may be used to provide the voice service even when the entire payload is not required by other services. The CPE presentation may be either an analogue presentation via an ATA or directly to a VoIP handset.

In order to achieve co-existence between reverse power feed and POTS various adaptors are required as described in clause 5.2.2 for use in the reverse power feed reference models.

## 5.2.2 POTS Adapters

The following three different types of POTS adaptor are specified for use in the reverse power feed reference models:

- 1) POTS Adapter - E (POTSA-E)
- 2) POTS Adapter - C (POTSA-C)
- 3) POTS Adapter - D (POTSA-D)

Where reverse power feed and POTS signals traverse the same copper wires a signalling system shall be implemented to allow the signalling at the POTS interface based on off-hook/on-hook DC impedance, and in those jurisdictions requiring it, line reversal for Calling Number ID alerting to be communicated across the copper pair from the DPU to the POTS terminals. This functionality can be provided by the various POTS adaptors described below.

### 5.2.2.1 POTS Adapter - E (POTSA-E)

POTS Adapter - E is the single adapter located at the DPU and this adapter shall perform the following functions:

- 1) Translate the downstream DC and low frequency POTS signalling into an in-band or out-of-band signalling system.
- 2) Translate the signals from the upstream in-band or out-of-band signalling system into DC and low frequency POTS signalling.

POTSA-E may provide a relay by-pass when un-powered (for life-line operation) or when signalled to provide direct access to the exchange to allow operations such as line-test to be performed.

### 5.2.2.2 POTS Adapter - C (POTSA-C)

POTS Adapter - C is the single adapter located at the NT module and this adapter shall perform the following functions:

- 1) Translate the upstream DC and low frequency POTS signalling from the POTS Terminal into an in-band or out-of-band signalling system.
- 2) Translate the downstream in-band or out-of-band signalling system into POTS signalling towards the POTS Terminal.
- 3) Provide sufficient current limit and DC voltage to supply one or more phone devices.
- 4) Provide a pre-defined rate of change of current increase when a phone device goes off-hook to allow for the detection of phone devices going off-hook that do not have the correct POTS adapter fitted.

POTSA-C may provide relay by-pass when un-powered (for lifeline operation) or when signalled to provide direct access to the exchange to allow operations such as line-tests to be performed.

### 5.2.2.3 POTS Adapter - D (POTSA-D)

POTS Adapter - D is the adapter that can be attached to every phone device connected to the in-premises wiring on the home network. This adapter operates in the presence of reverse powering. This adapter shall perform the following function:

- 1) Translate the signals from the upstream DC and low frequency POTS signalling from the POTS Terminal into an in-band or out-of-band signalling system.
- 2) Translate the signals from the downstream in-band or out-of-band signalling system into POTS signalling towards the POTS Terminal.
- 3) Provide sufficient current limit and DC voltage to supply a single phone device.
- 4) Provide a pre-defined rate of change of current increase when a phone device goes off-hook to allow for the detection of phone devices going off-hook that do not have the correct POTS adapter fitted.

### 5.3 Reverse Power Feed Architecture without POTS on the same pair (RPFA-NOP)

The functional reference model of the reverse power feed architecture without POTS on the same pair (RPFA-NOP) is shown in Figure 2. In this option, the reference model illustrates the RPF architecture with the broadband service only and no underlying narrowband service, neither exchange-based POTS nor derived POTS.

The xTU-O is located inside the Distribution Point Unit (DPU) at the network side of the wire pair (U-O reference point). The xTU-R is located inside the Network termination (NT) at the customer premises side of the wire pair (U-R reference point). Each DPU is located at a distribution point and can contain one or more xTU-O transceivers (xTU-O-I,  $I = 1 \dots N$ ), with each transceiver connected to an NT.

At the backhaul link termination, the PHY blocks represent the physical layer of the xTU-O module towards the access network and of the NT towards the customer premises (CP). These blocks are shown for completeness of the data flow but are out of scope of the present document. The L2+ blocks represent the Layer 2 and above functionalities contained in the xTU-O module and the NT. These blocks are shown for completeness of the data flow but are out of scope of the present document.

The traffic from all DPUs is aggregated by a backhaul transmission system operating over the Distribution Network (DN) and Higher Order Node (HON) up to the V reference point. The type of transmission system is out of scope of the present document.

The management of a DPU is performed by the network management system (NMS), passing management information to the DPU's management entity (DPU ME) over a management communications channel that is provided over the backhaul transmission system. The details of the management communications channel and most of the management functionality required for the DPU are out of scope of the present document.

As there is a need for management transactions between the DPU and the CPE for controlling the start-up of reverse powering to the DPU when mains power is applied to the CPE and for monitoring powering in normal operations, power management transceivers are connected to the copper drop in the DPU (PMT-I,  $I = 1 \dots N$ ) and the customer premises (PMT) to support a management protocol. The management information is exchanged between the PMT-I and DPU ME through the power management entity PME-D. At the customer premises, the information flow takes place between the PMT and CPE ME through the power management entity PME-C.

The power is inserted on the line (i.e. copper pair) by the Power Source Equipment (PSE) located in the customer premises and extracted from the line by the Power Extractor (PE-I,  $I = 1 \dots N$ ) located in the DPU. Power is extracted from each active port and combined in the Power Supply Unit (PSU) and coordinated over all lines by the Reverse Power Control Entity (RPCE). The PE and PSU are separated from the broadband signal on the line (at reference point U-O and U-R) by a power splitter (PS). Reverse power battery backup at the PDU and customer premises is illustrated in block BAT.