

---

---

**Refractory mortars —**

**Part 1:**

**Determination of consistency using the  
penetrating cone method**

*Mortiers réfractaires —*

*Partie 1: Détermination de la consistance par la méthode de pénétration  
d'un cône*

**STANDARD PREVIEW**  
**(standards.iteh.ai)**

ISO 13765-1:2004

<https://standards.iteh.ai/catalog/standards/sist/e87a7fec-c016-447d-b60b-f77176150e8b/iso-13765-1-2004>



Reference number  
ISO 13765-1:2004(E)

**PDF disclaimer**

This PDF file may contain embedded typefaces. In accordance with Adobe's licensing policy, this file may be printed or viewed but shall not be edited unless the typefaces which are embedded are licensed to and installed on the computer performing the editing. In downloading this file, parties accept therein the responsibility of not infringing Adobe's licensing policy. The ISO Central Secretariat accepts no liability in this area.

Adobe is a trademark of Adobe Systems Incorporated.

Details of the software products used to create this PDF file can be found in the General Info relative to the file; the PDF-creation parameters were optimized for printing. Every care has been taken to ensure that the file is suitable for use by ISO member bodies. In the unlikely event that a problem relating to it is found, please inform the Central Secretariat at the address given below.

**iTeh STANDARD PREVIEW**  
**(standards.iteh.ai)**

[ISO 13765-1:2004](https://standards.iteh.ai/catalog/standards/sist/e87a7fec-c016-447d-b60b-f77176150e8b/iso-13765-1-2004)

<https://standards.iteh.ai/catalog/standards/sist/e87a7fec-c016-447d-b60b-f77176150e8b/iso-13765-1-2004>

© ISO 2004

All rights reserved. Unless otherwise specified, no part of this publication may be reproduced or utilized in any form or by any means, electronic or mechanical, including photocopying and microfilm, without permission in writing from either ISO at the address below or ISO's member body in the country of the requester.

ISO copyright office  
Case postale 56 • CH-1211 Geneva 20  
Tel. + 41 22 749 01 11  
Fax + 41 22 749 09 47  
E-mail [copyright@iso.org](mailto:copyright@iso.org)  
Web [www.iso.org](http://www.iso.org)

Published in Switzerland

## Foreword

ISO (the International Organization for Standardization) is a worldwide federation of national standards bodies (ISO member bodies). The work of preparing International Standards is normally carried out through ISO technical committees. Each member body interested in a subject for which a technical committee has been established has the right to be represented on that committee. International organizations, governmental and non-governmental, in liaison with ISO, also take part in the work. ISO collaborates closely with the International Electrotechnical Commission (IEC) on all matters of electrotechnical standardization.

International Standards are drafted in accordance with the rules given in the ISO/IEC Directives, Part 2.

The main task of technical committees is to prepare International Standards. Draft International Standards adopted by the technical committees are circulated to the member bodies for voting. Publication as an International Standard requires approval by at least 75 % of the member bodies casting a vote.

Attention is drawn to the possibility that some of the elements of this document may be the subject of patent rights. ISO shall not be held responsible for identifying any or all such patent rights.

ISO 13765-1 was prepared by Technical Committee ISO/TC 33, *Refractories*.

ISO 13765 consists of the following parts, under the general title *Refractory mortars*:

- *Part 1: Determination of consistency using the penetrating cone method*
- *Part 2: Determination of consistency using the reciprocating flow table method*
- *Part 3: Determination of joint stability* [ISO 13765-1:2004](https://standards.iteh.ai/catalog/standards/sist/e87a7fcc-c016-447d-b60b-f77176150e8b/iso-13765-1-2004)
- *Part 4: Determination of flexural bonding strength*
- *Part 5: Determination of grain size distribution (sieve analysis)*
- *Part 6: Determination of moisture content of ready-mixed mortars*

**iTeh STANDARD PREVIEW**  
**(standards.iteh.ai)**

ISO 13765-1:2004

<https://standards.iteh.ai/catalog/standards/sist/e87a7fec-c016-447d-b60b-f77176150e8b/iso-13765-1-2004>

# Refractory mortars —

## Part 1: Determination of consistency using the penetrating cone method

### 1 Scope

This part of ISO 13765 describes a method for the determination of the consistency of refractory mortars using a penetrating cone.

### 2 Normative references

The following referenced documents are indispensable for the application of this document. For dated references, only the edition cited applies. For undated references, the latest edition of the referenced document (including any amendments) applies.

ISO 8656-1, *Refractory products — Sampling of raw materials and unshaped products — Part 1: Sampling scheme*

### 3 Terms and definitions

[ISO 13765-1:2004](https://standards.iteh.ai/catalog/standards/sist/e87a7fcc-c016-447d-b60b-f77176150e8b/iso-13765-1-2004)

<https://standards.iteh.ai/catalog/standards/sist/e87a7fcc-c016-447d-b60b-f77176150e8b/iso-13765-1-2004>

For the purposes of this document, the following terms and definitions apply.

#### 3.1

##### **refractory mortar**

finely ground refractory composition which, generally after the addition of water or other specified mixed liquid, is used for laying and jointing bricks

NOTE 1 The refractory components are related to the quality of the bricks with which the composition is to be used.

NOTE 2 In some cases the mortar may be supplied in a ready-mixed state.

#### 3.2

##### **consistency of refractory mortars**

measure of the viscosity of the material in its ready-to-use state

### 4 Principle

The consistency of a refractory mortar is assessed by the depth of penetration of a specified cone into the sample.

### 5 Apparatus

**5.1 Consistency determination device**, consisting of a penetrometer, a cone and a container for the sample.

The penetrometer is shown in Figure 1. The requirements for the cone and the sample container are given in 5.1.1 and 5.1.2.

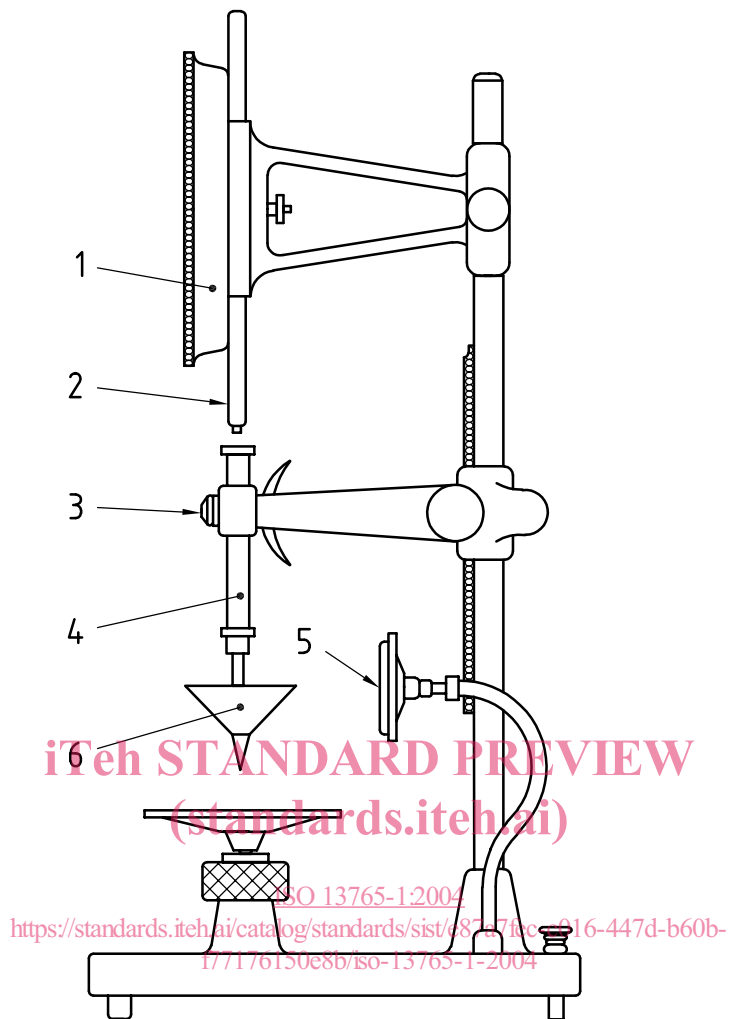

**Key**

- 1 gauge plate
- 2 toothed lever
- 3 button
- 4 drop rod
- 5 reflector
- 6 standard cone

NOTE Reflecor may or may not be used.

**Figure 1 — Penetrometer**

**5.1.1 Cone.**

The cone shall be made of brass or corrosion-resistant steel with a smooth, polished surface. It shall be of the dimensions shown in Figure 2, and shall be machined such that the mass of the cone and drop rod is  $150\text{ g} \pm 0,25\text{ g}$ . The cone shall be tightly fitted with no shoulder at the joint to a needle tip made of quench-hardened steel or stainless steel.

Dimensions in millimetres

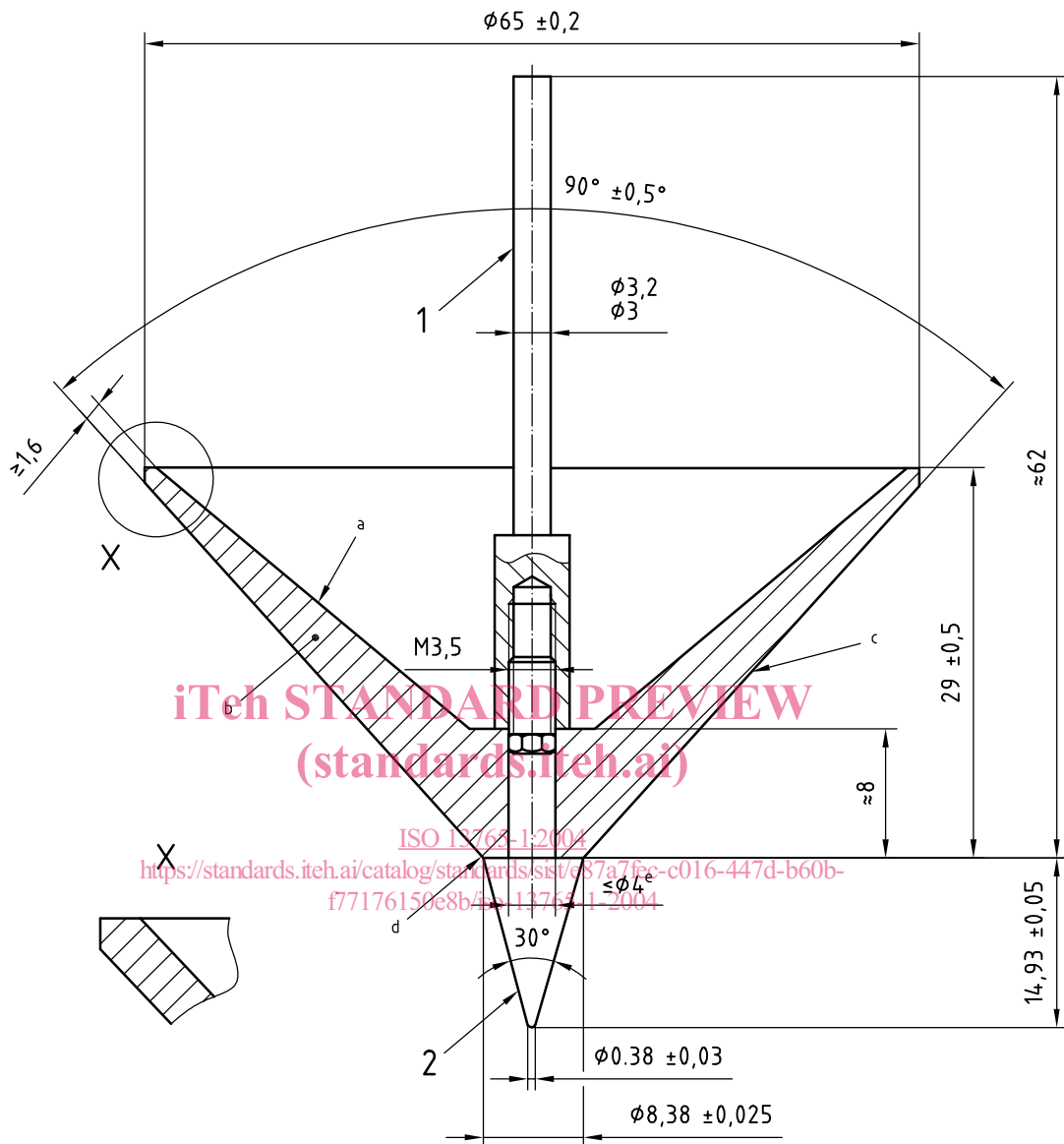

**Key**

- 1 stainless steel drop rod
- 2 needle tip (made of quench-hardened steel or stainless steel)
- a Machine to desired mass.
- b Brass or corrosion-resistant steel.
- c Smooth and polished surface.
- d Tight fit.
- e No shoulder, i.e. smooth transition.

**Figure 2 — Penetrometer cone**

**5.1.2 Sample container**, a cylinder of 100 mm internal diameter and 50 mm depth.

**5.2 Mixer**, (see Figure 3) consisting of a stainless steel bowl and a metal blade.

**5.2.1 Stainless steel bowl**, with a capacity of about 5 L and of the general shape and size shown in Figure 3, and provided with means by which it can be fixed securely to the mixer frame during mixing and by which the height of the bowl in relation to the blade and, to some extent, the gap between blade and bowl can be finely adjusted and fixed;

**5.2.2 Metal blade**, of the general shape, size and tolerances shown in Figure 3, rotating about its own axis as it is driven in a planetary movement around the axis of the bowl by an electric motor at controlled rotational frequencies.

The two directions of rotation shall be opposite and the ratio between the two frequencies shall not be a whole number.

Where more than one mixer is used, blades and bowls shall form sets which are always used together. The gap between blade and bowl shown in Figure 3 shall be checked regularly depending on the frequency of use.

NOTE The gap indicated in Figure 3 ( $3\text{ mm} \pm 1\text{ mm}$ ) refers to the situation when the blade in the empty bowl is brought as close as possible to the wall. Simple tolerance gauges (feeler gauges) are useful where direct measurement is difficult.

**5.3 Balance**, having a maximum weighing capacity of 6 kg and capable of weighing to the nearest 1 g.

**5.4 Measuring cylinder**, capable of measuring to the nearest 5 ml.

**5.5 Thermometer**, capable of measuring to the nearest  $1\text{ }^{\circ}\text{C}$ .

Dimensions in millimetres

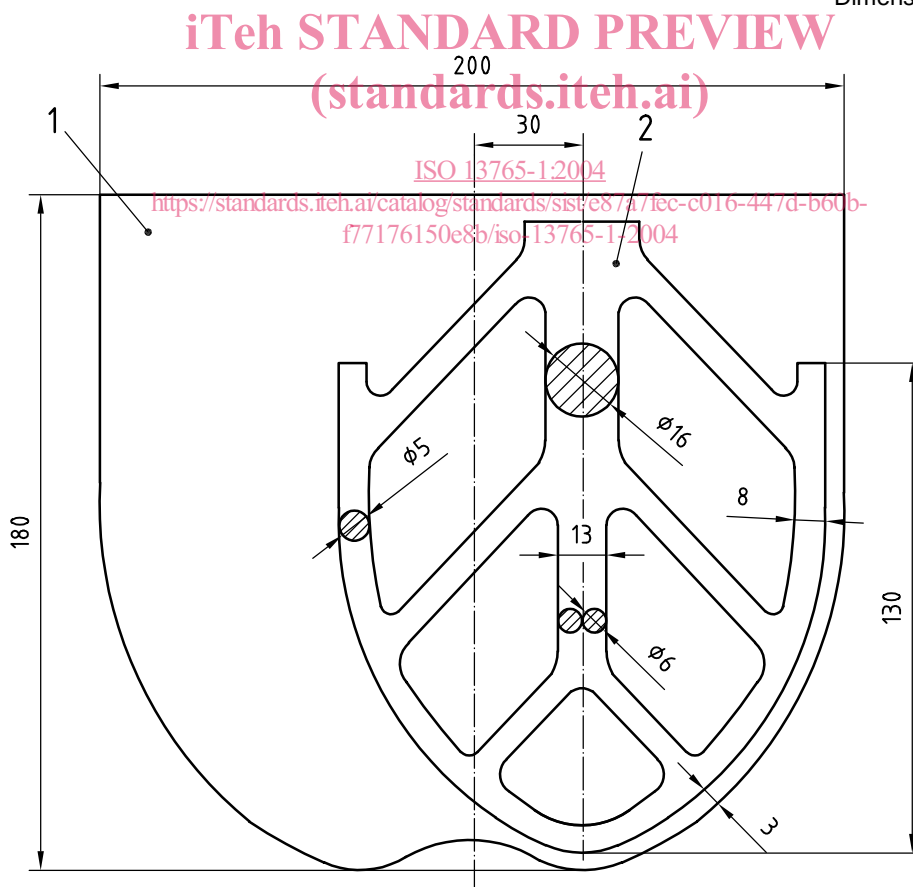

- Key**
- 1 bowl
  - 2 blade

Figure 3 — Mixer blade and bowl



## 6 Sampling

For dry mortar, sample the mortar in accordance with ISO 8656-1 or as agreed between parties. Reduce the sample to 5 kg by quartering or with a riffle sampler.

Sample ready-mixed mortars by emptying the entire contents of the container in which the mortar is supplied into another container of larger capacity and mixing thoroughly. It is important that any supernatant liquid not be discarded. Ensure that a representative sample of the wet mixture is obtained.

## 7 Procedure

**7.1** For dry mortars, place the mortar in the mixer and add water (or the specified mixing liquid) in accordance with the manufacturer's instructions and mix thoroughly. Note the quantity of liquid added. Allow the mixed mortar to stand for 15 min, unless any specific instructions are given by the manufacturer, in which case these should be followed. Ready-mixed mortar shall be tested in "as received" state.

**7.2** Measure the temperature of the mixed mortar to the nearest 1 °C.

**7.3** Set the penetrometer vertically and attach a clean dry cone.

**7.4** Fill the sample container with the well-mixed mortar, level the surface with a levelling rod and place it on the test table.

**7.5** Adjust the position of the cone so that its tip is just in contact with the centre of the surface of the mortar in the sample container. Lower the measuring gauge rod to contact the top of the drop rod and set the gauge to zero.

**7.6** Depress the start (release) button and keep depressed for 5 s so that the cone can move freely. Release the button. Lower the toothed rod again to contact the top of the drop rod. Record the value on the measuring gauge scale to the nearest 0,1 mm as the consistency of the mortar.

**7.7** Lift the toothed rod and cone. Clean the cone. Repeat the operation described in 7.3 to 7.6.

## 8 Calculation

Calculate the consistency as the mean value of the two tests to the nearest 0,1 mm.

In the case of dry mortars, calculate the percentage of the amount of water or mixing liquid added based on the mass of the dry material.

## 9 Test report

The report shall include the following information:

- a) all information necessary for identification of the material tested, including a description of the material, manufacturer, type, brand, batch number, etc.;
- b) a reference to this part of ISO 13765 (ISO 13765-1);
- c) the name of the testing establishment;
- d) in the case of a dry mortar, the percentage of water (or specified liquid) added;
- e) the results of the test, i.e. the consistency as penetration to the nearest 0,1 mm, including the results of the individual determinations and their mean, calculated as specified in Clause 8;
- f) the ambient temperature at which the test was conducted;
- g) the temperature of the mixed mortar;
- h) any deviations from the procedure specified;