Refractory mortars —
Part 3:
Determination of joint stability

Mortiers réfractaires —

Partie 3: Détermination de la stabilité des joints

iTeh STANDARD PREVIEW
(standards.iteh.ai)

ISO 13765-3:2004

<https://standards.iteh.ai/catalog/standards/sist/0fd7f152-6f47-4e95-9ec3-6a0d4cea1178/iso-13765-3-2004>



PDF disclaimer

This PDF file may contain embedded typefaces. In accordance with Adobe's licensing policy, this file may be printed or viewed but shall not be edited unless the typefaces which are embedded are licensed to and installed on the computer performing the editing. In downloading this file, parties accept therein the responsibility of not infringing Adobe's licensing policy. The ISO Central Secretariat accepts no liability in this area.

Adobe is a trademark of Adobe Systems Incorporated.

Details of the software products used to create this PDF file can be found in the General Info relative to the file; the PDF-creation parameters were optimized for printing. Every care has been taken to ensure that the file is suitable for use by ISO member bodies. In the unlikely event that a problem relating to it is found, please inform the Central Secretariat at the address given below.

iTeh STANDARD PREVIEW
(standards.iteh.ai)

[ISO 13765-3:2004](https://standards.iteh.ai/catalog/standards/sist/0fd7f152-6f47-4e95-9ec3-6a0d4cea1178/iso-13765-3-2004)

<https://standards.iteh.ai/catalog/standards/sist/0fd7f152-6f47-4e95-9ec3-6a0d4cea1178/iso-13765-3-2004>

© ISO 2004

All rights reserved. Unless otherwise specified, no part of this publication may be reproduced or utilized in any form or by any means, electronic or mechanical, including photocopying and microfilm, without permission in writing from either ISO at the address below or ISO's member body in the country of the requester.

ISO copyright office
Case postale 56 • CH-1211 Geneva 20
Tel. + 41 22 749 01 11
Fax + 41 22 749 09 47
E-mail copyright@iso.org
Web www.iso.org

Published in Switzerland

Foreword

ISO (the International Organization for Standardization) is a worldwide federation of national standards bodies (ISO member bodies). The work of preparing International Standards is normally carried out through ISO technical committees. Each member body interested in a subject for which a technical committee has been established has the right to be represented on that committee. International organizations, governmental and non-governmental, in liaison with ISO, also take part in the work. ISO collaborates closely with the International Electrotechnical Commission (IEC) on all matters of electrotechnical standardization.

International Standards are drafted in accordance with the rules given in the ISO/IEC Directives, Part 2.

The main task of technical committees is to prepare International Standards. Draft International Standards adopted by the technical committees are circulated to the member bodies for voting. Publication as an International Standard requires approval by at least 75 % of the member bodies casting a vote.

Attention is drawn to the possibility that some of the elements of this document may be the subject of patent rights. ISO shall not be held responsible for identifying any or all such patent rights.

ISO 13765-3 was prepared by Technical Committee ISO/TC 33, *Refractories*.

ISO 13765 consists of the following parts, under the general title *Refractory mortars*:

- *Part 1: Determination of consistency using the penetrating cone method*
- *Part 2: Determination of consistency using the reciprocating flow table method*
- *Part 3: Determination of joint stability* [ISO 13765-3:2004](https://standards.iteh.ai/catalog/standards/sist/0fd7f152-6f47-4e95-9ec3-6a0d4cea1178/iso-13765-3-2004)
- *Part 4: Determination of flexural bonding strength*
- *Part 5: Determination of grain size distribution (sieve analysis)*
- *Part 6: Determination of moisture content of ready-mixed mortars*

iTeh STANDARD PREVIEW
(standards.iteh.ai)

ISO 13765-3:2004

<https://standards.iteh.ai/catalog/standards/sist/0fd7f152-6f47-4e95-9ec3-6a0d4cea1178/iso-13765-3-2004>

Refractory mortars —

Part 3: Determination of joint stability

1 Scope

This part of ISO 13765 describes a method of determination of joint stability of refractory mortars.

2 Normative references

The following referenced documents are indispensable for the application of this document. For dated references, only the edition cited applies. For undated references, the latest edition of the referenced document (including any amendments) applies.

ISO 8656-1, *Refractory products — Sampling of raw materials and unshaped products — Part 1: Sampling scheme*

ISO 13765-1, *Refractory mortars — Part 1: Determination of consistency using the penetrating cone method*

ISO 13765-2, *Refractory mortars — Part 2: Determination of consistency using the reciprocating flow table method*

<https://standards.iteh.ai/catalog/standards/sist/0fd7f152-6f47-4e95-9ec3-6a0d4cea1178/iso-13765-3-2004>

3 Terms and definitions

For the purposes of this document, the following terms and definitions apply.

3.1

joint stability

stability of the mortar joint between bricks when moving by hand one brick jointed to another without breaking the joint

NOTE The time over which this operation is possible before the mortar becomes dry due to loss of specified mixing liquid is used as the time of joint stability.

4 Principle

Trials are carried out laying refractory bricks with a mortar to determine the time of joint stability of the refractory mortar.

5 Apparatus

5.1 Mixer, as specified in ISO 13765-1 or ISO 13765-2.

5.2 Electrical drying oven, fitted with a temperature controller and capable of operating at $110\text{ °C} \pm 5\text{ °C}$.

5.3 Consistency determining device, as specified in ISO 13765-1 or ISO 13765-2.

5.4 Balance, with a weighing capacity of 10 kg and capable of weighing to the nearest 1 g.

5.5 Stopwatch.

5.6 Spacing rods, made of clean metal (e.g. stainless steel) and with a diameter of $3\text{ mm} \pm 0,1\text{ mm}$.

5.7 Measuring cylinder.

6 Sampling

For dry mortar, sample the mortar in accordance with ISO 8656-1 or as agreed between parties. Reduce the sample to 5 kg by quartering or with a riffle sampler.

Sample ready-mixed mortars by emptying the entire contents of the container in which the mortar is supplied into another container of larger capacity and mixing thoroughly. It is important that any supernatant liquid not be discarded. Ensure that a representative sample of the wet mixture is obtained.

7 Procedure

7.1 Place four standard bricks, $230\text{ mm} \times 114\text{ mm} \times 76\text{ mm}$, with smooth surfaces and clean edges (remove any dust with a hard brush) in the drying oven and dry for at least 24 h, then cool to room temperature naturally. The bricks used in the test shall be compatible with the mortar to be tested.

7.2 For dry mortars, place the mortar in the mixer and add water (or a specified mixing liquid) to the sample and mix thoroughly to attain the desired consistency. Allow the mixed mortar to stand for 30 min or in accordance with the manufacturer's instructions. Ready-mixed mortars shall be tested in the "as-received" state. Note the consistency in accordance with ISO 13765-1 or ISO 13765-2.

7.3 Apply the well-mixed mortar to the $230\text{ mm} \times 114\text{ mm}$ face of the dried refractory brick. The longitudinal faces of each brick shall be parallel to each other within a tolerance of $\pm 1\text{ mm}$ and the sides of a cross-section of the brick shall be parallel to each other within a tolerance of $0,5\text{ mm}$. Position two spacing rods in the mortar layer parallel to and 30 mm from the 114-mm edges. Place another brick on top as shown in Figure 1.

6a0d4cea1178/iso-13765-3-2004

Dimensions in millimetres

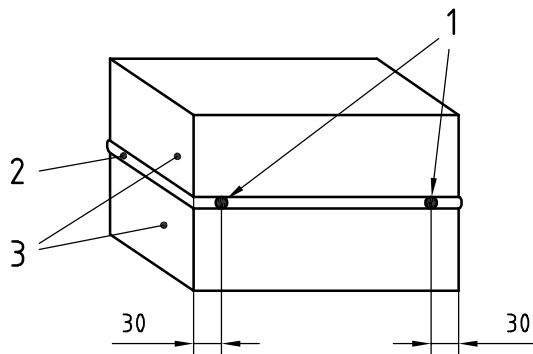

- Key**
- 1 metal rod
 - 2 mortar
 - 3 brick

Figure 1 — Placement of bricks

7.4 Press lightly on the top brick while moving it in a to-and-fro motion along the 230-mm direction until a joint of 3 mm is achieved.

7.5 Withdraw the spacing rods, avoiding disruption of the joint and remove the excess mortar from the edges of the joint. Start the stopwatch and move the top brick back and forth in the 230-mm direction without breaking the joint. When the brick can no longer be moved in this way, stop the stopwatch and record the time elapsed in seconds.

7.6 Repeat the operation from 7.3 to 7.5 for the second pair of bricks.

8 Expression of results

Report the joint stability of the mortar as the mean of the two measurements, in seconds.

9 Test report

The report shall include the following information:

- a) all information necessary for identification of the material tested, including a description of the material, manufacturer, type, brand, batch number, etc.;
- b) a reference to this part of ISO 13765 (ISO 13765-3);
- c) the name of the testing establishment;
- d) the type, brand and manufacturer of the refractory bricks used in the test;
- e) in the case of a dry mortar, the percentage of water (or specified liquid) added;
- f) the results of the test, i.e. the joint stability time in seconds, including the results of the individual determinations and their mean, calculated as specified in Clause 8;
- g) the consistency of the mortar tested and the method used to determine the consistency, i.e. ISO 13765-1 or ISO 13765-2;
- h) the ambient temperature at which the test was conducted;
- i) any deviations from the procedure specified;
- j) any unusual features (anomalies) observed during the test;
- k) the date of the test.

iTeh STANDARD PREVIEW
(standards.iteh.ai)

ISO 13765-3:2004

<https://standards.iteh.ai/catalog/standards/sist/0fd7f152-6f47-4e95-9ec3-6a0d4cea1178/iso-13765-3-2004>

ICS 81.080

Price based on 3 pages