

---

---

**Optics and optical instruments — Field  
procedures for testing geodetic and  
surveying instruments —**

Part 6:  
**Rotating lasers**

iTeh STANDARD PREVIEW

*Optique et instruments d'optique — Méthodes d'essai sur site des  
instruments géodésiques et d'observation —*

*Partie 6: Lasers rotatifs*

*ISO 17123-6:2003*

<https://standards.iteh.ai/catalog/standards/sist/1eb8c72f-ce60-456a-8bd2-a66000b35ad7/iso-17123-6-2003>



**PDF disclaimer**

This PDF file may contain embedded typefaces. In accordance with Adobe's licensing policy, this file may be printed or viewed but shall not be edited unless the typefaces which are embedded are licensed to and installed on the computer performing the editing. In downloading this file, parties accept therein the responsibility of not infringing Adobe's licensing policy. The ISO Central Secretariat accepts no liability in this area.

Adobe is a trademark of Adobe Systems Incorporated.

Details of the software products used to create this PDF file can be found in the General Info relative to the file; the PDF-creation parameters were optimized for printing. Every care has been taken to ensure that the file is suitable for use by ISO member bodies. In the unlikely event that a problem relating to it is found, please inform the Central Secretariat at the address given below.

**iTeh STANDARD PREVIEW**  
**(standards.iteh.ai)**

[ISO 17123-6:2003](https://standards.iteh.ai/catalog/standards/sist/1eb8c72f-ce60-456a-8bd2-a66000b35ad7/iso-17123-6-2003)

<https://standards.iteh.ai/catalog/standards/sist/1eb8c72f-ce60-456a-8bd2-a66000b35ad7/iso-17123-6-2003>

© ISO 2003

All rights reserved. Unless otherwise specified, no part of this publication may be reproduced or utilized in any form or by any means, electronic or mechanical, including photocopying and microfilm, without permission in writing from either ISO at the address below or ISO's member body in the country of the requester.

ISO copyright office  
Case postale 56 • CH-1211 Geneva 20  
Tel. + 41 22 749 01 11  
Fax + 41 22 749 09 47  
E-mail [copyright@iso.org](mailto:copyright@iso.org)  
Web [www.iso.org](http://www.iso.org)

Published in Switzerland

**Contents**

Page

<b>Foreword</b> .....	<b>iv</b>
<b>1 Scope</b> .....	<b>1</b>
<b>2 Normative references</b> .....	<b>1</b>
<b>3 Terms and definitions</b> .....	<b>2</b>
<b>4 General</b> .....	<b>2</b>
<b>5 Simplified test procedure</b> .....	<b>4</b>
<b>6 Full test procedure</b> .....	<b>6</b>
<b>Annex A (informative) Example of the simplified test procedure</b> .....	<b>14</b>
<b>Annex B (informative) Example of the full test procedure</b> .....	<b>17</b>

**iTeh STANDARD PREVIEW**  
**(standards.iteh.ai)**

[ISO 17123-6:2003](https://standards.iteh.ai/catalog/standards/sist/1eb8c72f-ce60-456a-8bd2-a66000b35ad7/iso-17123-6-2003)

<https://standards.iteh.ai/catalog/standards/sist/1eb8c72f-ce60-456a-8bd2-a66000b35ad7/iso-17123-6-2003>

## Foreword

ISO (the International Organization for Standardization) is a worldwide federation of national standards bodies (ISO member bodies). The work of preparing International Standards is normally carried out through ISO technical committees. Each member body interested in a subject for which a technical committee has been established has the right to be represented on that committee. International organizations, governmental and non-governmental, in liaison with ISO, also take part in the work. ISO collaborates closely with the International Electrotechnical Commission (IEC) on all matters of electrotechnical standardization.

International Standards are drafted in accordance with the rules given in the ISO/IEC Directives, Part 2.

The main task of technical committees is to prepare International Standards. Draft International Standards adopted by the technical committees are circulated to the member bodies for voting. Publication as an International Standard requires approval by at least 75 % of the member bodies casting a vote.

Attention is drawn to the possibility that some of the elements of this document may be the subject of patent rights. ISO shall not be held responsible for identifying any or all such patent rights.

ISO 17123-6 was prepared by Technical Committee ISO/TC 172, *Optics and optical instruments*, Subcommittee SC 6, *Geodetic and surveying instruments*.

This first edition of ISO 17123-6 cancels and replaces ISO 8322-6:1991, which has been technically revised.

ISO 17123 consists of the following parts, under the general title *Optics and optical instruments — Field procedures for testing geodetic and surveying instruments*:

- *Part 1: Theory*
- *Part 2: Levels*
- *Part 3: Theodolites*
- *Part 4: Electro-optical distance meters (EDM instruments)*
- *Part 5: Electronic tacheometers*
- *Part 6: Rotating lasers*
- *Part 7: Optical plumbing instruments*

# Optics and optical instruments — Field procedures for testing geodetic and surveying instruments —

## Part 6: Rotating lasers

### 1 Scope

This part of ISO 17123 specifies field procedures to be adopted when determining and evaluating the precision (repeatability) of rotating lasers and their ancillary equipment when used in building and surveying measurements for levelling tasks. Primarily, these tests are intended to be field verifications of the suitability of a particular instrument for the immediate task at hand and to satisfy the requirements of other standards. They are not proposed as tests for acceptance or performance evaluations that are more comprehensive in nature.

This part of ISO 17123 can be thought of as one of the first steps in the process of evaluating the uncertainty of a measurement (more specifically a measurand). The uncertainty of a result of a measurement is dependent on a number of factors. These include among others: repeatability, reproducibility (between day repeatability) and a thorough assessment of all possible error sources, as prescribed by the ISO Guide to the expression of uncertainty in measurement (GUM).

These field procedures have been developed specifically for *in situ* applications without the need for special ancillary equipment and are purposefully designed to minimize atmospheric influences.

### 2 Normative references

The following referenced documents are indispensable for the application of this document. For dated references, only the edition cited applies. For undated references, the latest edition of the referenced document (including any amendments) applies.

ISO 3534-1, *Statistics — Vocabulary and symbols — Part 1: Probability and general statistical terms*

ISO 4463-1, *Measurement methods for building — Setting-out and measurement — Part 1: Planning and organization, measuring procedures, acceptance criteria*

ISO 7077, *Measuring methods for building — General principles and procedures for the verification of dimensional compliance*

ISO 7078, *Building construction — Procedures for setting out, measurement and surveying — Vocabulary and guidance notes*

ISO 9849, *Optics and optical instruments — Geodetic and surveying instruments — Vocabulary*

ISO 17123-1, *Optics and optical instruments — Field procedures for testing geodetic and surveying instruments — Part 1: Theory*

ISO 17123-2, *Optics and optical instruments — Field procedures for testing geodetic and surveying instruments — Part 2: Levels*

GUM, *Guide to the expression of uncertainty in measurement* BIPM, IEC, IFCC, ISO, IUPAC, IUPAP, OIML

VIM, *International vocabulary of basic and general terms in metrology* BIPM, IEC, IFCC, ISO, IUPAC, IUPAP, OIML

### 3 Terms and definitions

For the purposes of this document, the terms and definitions given in ISO 3534-1, ISO 4463-1, ISO 7077, ISO 7078, ISO 9849, ISO 17123-1, ISO 17123-2, GUM and VIM apply.

## 4 General

### 4.1 Requirements

Before commencing surveying, it is important that the operator investigates that the precision in use of the measuring equipment is appropriate to the intended measuring task.

The rotating laser and its ancillary equipment shall be in known and acceptable states of permanent adjustment according to the methods specified in the manufacturer's handbook, and used with tripods and levelling staffs as recommended by the manufacturer.

The results of these tests are influenced by meteorological conditions, especially by the temperature gradient. An overcast sky and low wind speed guarantee the most favourable weather conditions. The particular conditions to be taken into account may vary depending on where the tasks are to be undertaken. Note should also be taken of the actual weather conditions at the time of measurement and the type of surface above which the measurements are made. The conditions chosen for the tests should match those expected when the intended measuring task is actually carried out (see ISO 7077 and ISO 7078).

Tests performed in laboratories would provide results which are almost unaffected by atmospheric influences, but the costs for such tests are very high, and therefore they are not practicable for most users. In addition, laboratory tests yield precisions much higher than those that can be obtained under field conditions.

This part of ISO 17123 describes two different field procedures as given in Clauses 5 and 6. The operator shall choose the procedure which is most relevant to the project's particular requirements.

### 4.2 Procedure 1: Simplified test procedure

The simplified test procedure provides an estimate as to whether the precision of a given rotating-laser equipment is within the specified permitted deviation, according to ISO 4463-1.

This test procedure is normally intended for checking the precision of a rotating laser to be used for area levelling applications, for tasks where measurements with unequal site lengths are common practice, e.g. building construction sites.

The simplified test procedure is based on a limited number of measurements. Therefore, a significant standard deviation cannot be obtained. If a more precise assessment of the rotating laser under field conditions is required, it is recommended to adopt the more rigorous full test procedure as given in Clause 6.

This test procedure relies on having a test field with height differences which are accepted as true values. If such a test field is not available, it is necessary to determine the unknown height differences (see Figures 1 and 2), using an optical level of accuracy (see ISO 17123-2) higher than the rotating laser required for the measuring task. If, however, a test field with known height differences cannot be established, it will be necessary to apply the full test procedure as given in Clause 6.

If no levelling instrument is available, the rotating laser to be tested can be used to determine the true values by measuring height differences between all points with central setups. At each setup, two height differences

have to be observed by rotating the laser plane by 180°. The mean value of repeated readings in both positions will provide the height difference which is accepted as true.

### 4.3 Procedure 2: Full test procedure

The full test procedure shall be adopted to determine the best achievable measure of precision of a particular rotating laser and its ancillary equipment under field conditions, by a single survey team.

Further, this test procedure serves to determine the deflective deviation,  $a$ , and both components,  $b_1$  and  $b_2$ , of the deviation of the rotating axis from the true vertical,  $b = \sqrt{b_1^2 + b_2^2}$ , of the rotating laser (see Figure 1).

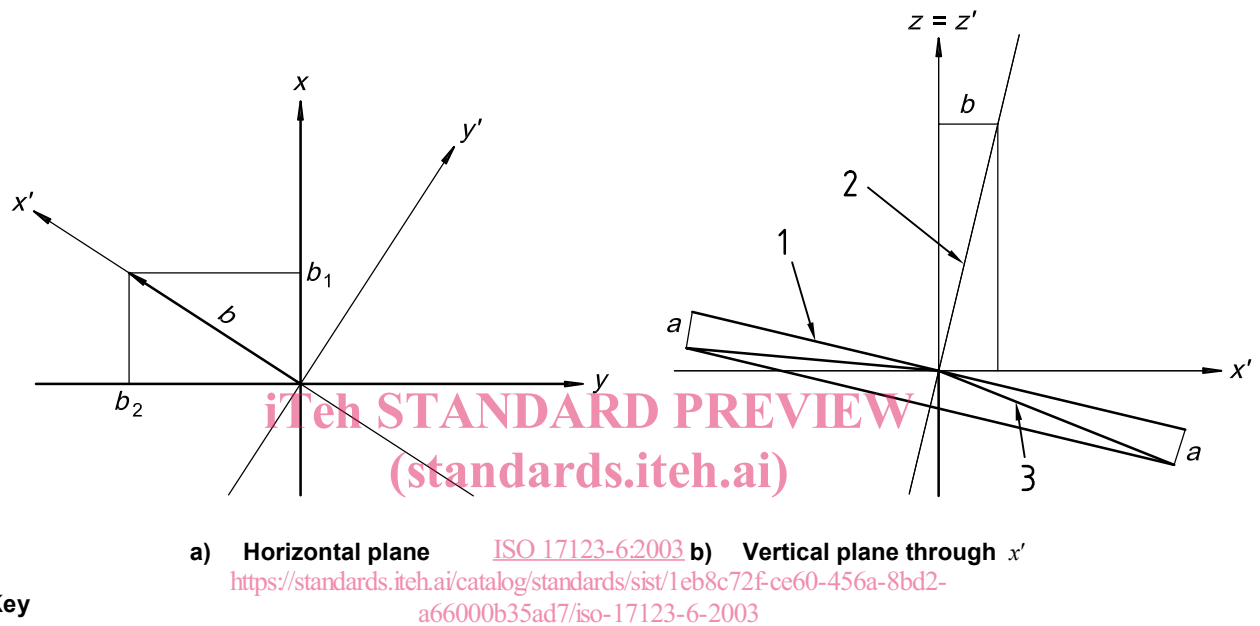

#### Key

- 1 inclined plane
- 2 cone axis
- 3 inclined cone

**Figure 1 — Deflective deviations  $a$  and  $b$  (see Figure 5)**

The recommended sight lengths are 40 m. Sight lengths greater than 40 m may be adopted for this precision-in-use test where the project specification may dictate, or to determine the range of the measure of precision of a rotating laser at respective distances.

The test procedure given in Clause 6 of this part of ISO 17123 is intended for determining the measure of precision in use of a particular rotating laser. This measure of precision in use is expressed in terms of the experimental standard deviation,  $s$ , of a height difference between the instrument level and a levelling staff (reading at the staff) at a distance of 40 m:

<sup>s</sup>ISO-ROLAS

Further, this procedure may be used to determine:

- the measure of precision in use of rotating lasers by a single survey team with a single instrument and its ancillary equipment at a given time;
- the measure of precision in use of a single instrument over time and differing environmental conditions;
- the measure of precision in use of each of several rotating lasers in order to enable a comparison of their respective achievable precisions to be obtained under similar field conditions.

Statistical tests should be applied to determine whether the experimental standard deviation,  $s$ , obtained belongs to the population of the instrumentation's theoretical standard deviation,  $\sigma$ , whether two tested samples belong to the same population, whether the deflective deviation,  $a$ , is equal to zero, and whether the deviation,  $b$ , of the rotating axis from the true vertical of the rotating laser is equal to zero.

## 5 Simplified test procedure

### 5.1 Configuration of the test field

To keep the influence of refraction as small as possible, a reasonably horizontal test area shall be chosen. Six fixed target points, 1, 2, 3, 4, 5 and 6, shall be set up in approximately the same horizontal plane at different distances, between 10 m and 60 m apart from the instrument station S. The directions from the instrument to the six fixed points shall be spread over the horizon as regularly as possible (see Figure 2).

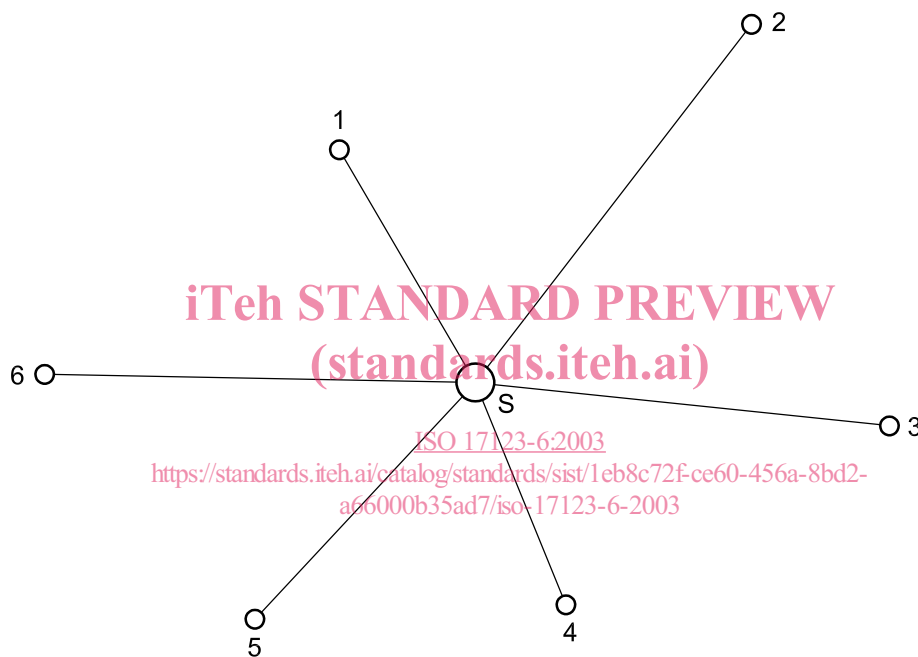

**Key**

- S instrument station
- 1, 2, 3, 4, 5, 6 fixed target points

**Figure 2 — Configuration of the test field for the simplified test procedure**

To ensure reliable results, the target points shall be marked in a stable manner, reliably fixed during the test measurements, including repeat measurements.

The height differences between the six fixed points, 1, 2, 3, 4, 5 and 6, shall be determined using an optical level of known high accuracy as described in Clause 4.

The following five height differences are known:

- $\bar{d}_{2,1}$
- $\bar{d}_{3,2}$
- $\bar{d}_{4,3}$
- $\bar{d}_{5,4}$
- $\bar{d}_{6,5}$



## 5.2 Measurements

The instrument shall be set up in a stable manner above point S. Before commencing the measurements, the laser beam shall become steady. To assure that the laser plane of the instrument remains unchanged during the whole measuring cycle, a fixed target shall be observed before and after each set of measurements number,  $j$  ( $j = 1, \dots, 5$ ).

Six separate readings,  $x_{j,1}, \dots, x_{j,6}$ , on the scale of the levelling staff shall be carried out to each fixed target point, 1, ..., 6. Between two sets of readings the instrument has to be lifted, turned clockwise approximately  $70^\circ$ , placed in a slightly different position and relevelled. The time between any two sets of readings shall be at least 10 min.

Each reading shall be taken in a precise mode according to the recommendations of the manufacturer.

## 5.3 Calculation

The evaluation of the readings is based on the following differences:

$$\begin{aligned}
 d_{j,2,1} &= x_{j,2} - x_{j,1} \\
 d_{j,3,2} &= x_{j,3} - x_{j,2} \\
 d_{j,4,3} &= x_{j,4} - x_{j,3} \\
 d_{j,5,4} &= x_{j,5} - x_{j,4} \\
 d_{j,6,5} &= x_{j,6} - x_{j,5}
 \end{aligned}
 \qquad j = 1, \dots, 5
 \tag{1}$$

iTeh STANDARD PREVIEW  
(standards.iteh.ai)

[ISO 17123-6:2003](https://standards.iteh.ai/catalog/standards/sist/1eb8c72f-ce60-456a-8bd2-a66000b35ad7/iso-17123-6-2003)

where

<https://standards.iteh.ai/catalog/standards/sist/1eb8c72f-ce60-456a-8bd2-a66000b35ad7/iso-17123-6-2003>

$j$  is the number of the set of measurements to the fixed target points, 1, ..., 6;

$$\begin{aligned}
 r_{j,2,1} &= \bar{d}_{2,1} - d_{j,2,1} \\
 r_{j,3,2} &= \bar{d}_{3,2} - d_{j,3,2} \\
 r_{j,4,3} &= \bar{d}_{4,3} - d_{j,4,3} \\
 r_{j,5,4} &= \bar{d}_{5,4} - d_{j,5,4} \\
 r_{j,6,5} &= \bar{d}_{6,5} - d_{j,6,5}
 \end{aligned}
 \qquad j = 1, \dots, 5
 \tag{2}$$

where  $r_{j,t,t-1}$  ( $t = 2, \dots, 6$  is the number of the fixed target points) is the residual of the height difference  $d_{j,t,t-1}$ .

$$\sum r^2 = \sum_{j=1}^5 r_{j,2,1}^2 + \sum_{j=1}^5 r_{j,3,2}^2 + \sum_{j=1}^5 r_{j,4,3}^2 + \sum_{j=1}^5 r_{j,5,4}^2 + \sum_{j=1}^5 r_{j,6,5}^2 = \sum_{j=1}^5 \sum_{t=2}^6 r_{j,t,t-1}^2
 \tag{3}$$

where

$\sum r^2$  is the sum of the squares of all 25 residuals;

$\nu = 5 \times (6 - 1) = 25$  is the corresponding number of degrees of freedom.

$$s = \sqrt{\frac{\sum r^2}{\nu}} \tag{4}$$

where  $s$  is the experimental standard deviation of a single measured height difference,  $d_{j,t,t-1}$ , between two points of the test field and represents in this International Standard a measure of precision. This value includes systematic and random errors.

## 6 Full test procedure

### 6.1 Configuration of the test line

To keep the influence of refraction as small as possible, a reasonably horizontal test area shall be chosen. The ground shall be compact and the surface shall be uniform; roads covered with asphalt or concrete shall be avoided. If there is direct sunlight, the instrument and the levelling staffs shall be shaded, for example by an umbrella.

Two levelling points, A and B, shall be set up approximately 40 m apart. To ensure reliable results, the levelling staffs shall be set up in stable positions, reliably fixed during the test measurements, including any repeat measurements. The instrument shall be placed at the positions S1, S2 and S3. The distances from the instrument's positions to the levelling points shall be in accordance with Figure 3. The position S1 shall be chosen equidistant between the levelling points, A and B (40/2 = 20 m).

<https://standards.iteh.ai/catalog/standards/sist/1eb8c72f-ce60-456a-8bd2-a66000b35ad7/iso-17123-6-2003>

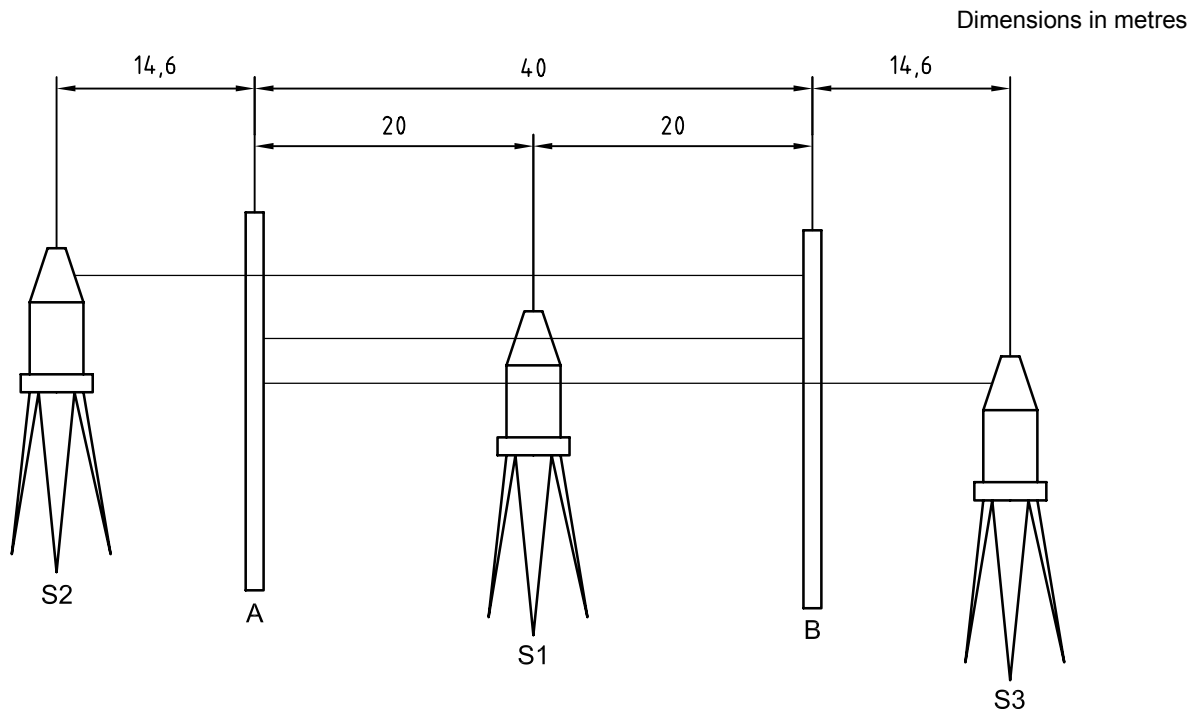

Figure 3 — Configuration of the test line for the full test procedure

**6.2 Measurements**

Before commencing the measurements, the instrument shall be adjusted as specified by the manufacturer.

For the full test procedure,  $m = 4$  series of measurements, ( $i$ ), shall be taken. Each of which requires the instrument to be set up on the three positions, S1, S2 and S3. After setting up the instrument, the laser beam shall become steady.

The readings at the two levelling points, A and B, shall be performed in  $n = 4$  sets, ( $j$ ), from each instrument position, the instrument being rotated by  $90^\circ$ . The instrument shall always be set up in the same orientation in three positions, S1, S2 and S3, in order to ensure that the instrument deviation is always directed to the same cardinal point of the compass. The direction of rotation shall be maintained. The different directions shall be selected in accordance with the possible given axes of the instrument.

With each new set-up of the chosen reference direction (reference marks on the tripod head), the instrument shall be relevelled carefully. If the instrument is provided with a compensator, care shall be taken that it functions properly. In the ground plane, the 4 orientations of the instrument in the 3 instrument positions, 1, 2 and 3, and the numbering of the 12 measurements can be represented for each measuring set as shown in Figure 4. Each reading shall be taken in a precise mode according to the recommendations of the manufacturer.

	A      S1      B 	S2   A                  B 	A                  B      S3 
Orientation	$j$	$j$	$j$
	1	5	9
	2	6	10
	3	7	11
	4	8	12

**Figure 4 — Arrangement of the measurements**