



**SLOVENSKI STANDARD**  
**SIST EN 15287-1:2008+A1:2010**  
**01-december-2010**

**Nadomešča:**  
**SIST EN 15287-1:2008**

---

**Dimniki - Projektiranje, vgradnja in pregled dimnikov - 1. del: Dimniki za ogrevalne naprave v netesnih prostorih**

Chimneys - Design, installation and commissioning of chimneys - Part 1: Chimneys for non-roomsealed heating appliances

Abgasanlagen - Planung, Montage und Abnahme von Abgasanlagen - Teil 1:  
Abgasanlagen für raumluftabhängige Feuerstätten

Conduits de fumée - Conception, installation et mise en service des conduits de fumée -  
Partie 1: Conduits de fumée pour appareils de combustion  
qui prélèvent l'air comburant dans la pièce

**Ta slovenski standard je istoveten z: EN 15287-1:2007+A1:2010**

---

**ICS:**

91.060.40 Dimniki, jaški, kanali Chimneys, shafts, ducts

**SIST EN 15287-1:2008+A1:2010 en,fr,de**

**iTeh STANDARD PREVIEW**  
**(standards.iteh.ai)**

SIST EN 15287-1:2008+A1:2010

<https://standards.iteh.ai/catalog/standards/sist/593843d5-a1fc-425d-b174-1f29e168a2af/sist-en-15287-1-2008a1-2010>

EUROPEAN STANDARD  
NORME EUROPÉENNE  
EUROPÄISCHE NORM

**EN 15287-1:2007+A1**

August 2010

ICS 91.060.40

Supersedes EN 15287-1:2007

English Version

## Chimneys - Design, installation and commissioning of chimneys - Part 1: Chimneys for non-roomsealed heating appliances

Conduits de fumée - Conception, installation et mise en  
oeuvre des conduits de fumée - Partie 1: Conduits de fumée  
pour appareils qui dépendent de l'air dans la pièce

Abgasanlagen - Planung, Montage und Abnahme von  
Abgasanlagen - Teil 1: Abgasanlagen für  
raumlufthängige Feuerstätten

This European Standard was approved by CEN on 28 July 2007 and includes Amendment 1 approved by CEN on 28 July 2010.

CEN members are bound to comply with the CEN/CENELEC Internal Regulations which stipulate the conditions for giving this European Standard the status of a national standard without any alteration. Up-to-date lists and bibliographical references concerning such national standards may be obtained on application to the CEN Management Centre or to any CEN member.

This European Standard exists in three official versions (English, French, German). A version in any other language made by translation under the responsibility of a CEN member into its own language and notified to the CEN Management Centre has the same status as the official versions.

CEN members are the national standards bodies of Austria, Belgium, Bulgaria, Croatia, Cyprus, Czech Republic, Denmark, Estonia, Finland, France, Germany, Greece, Hungary, Iceland, Ireland, Italy, Latvia, Lithuania, Luxembourg, Malta, Netherlands, Norway, Poland, Portugal, Romania, Slovakia, Slovenia, Spain, Sweden, Switzerland and United Kingdom.

[SIST EN 15287-1:2008+A1:2010](https://standards.iteh.ai/catalog/standards/sist/593843d5-a1fc-425d-b174-1f29e168a2af/sist-en-15287-1-2008a1-2010)

<https://standards.iteh.ai/catalog/standards/sist/593843d5-a1fc-425d-b174-1f29e168a2af/sist-en-15287-1-2008a1-2010>



EUROPEAN COMMITTEE FOR STANDARDIZATION  
COMITÉ EUROPÉEN DE NORMALISATION  
EUROPÄISCHES KOMITEE FÜR NORMUNG

Management Centre: Avenue Marnix 17, B-1000 Brussels

## Contents

Page

Foreword.....	3
Introduction .....	4
<b>1 Scope .....</b>	<b>5</b>
<b>2 Normative references .....</b>	<b>5</b>
<b>3 Terms and definitions .....</b>	<b>6</b>
<b>4 Design .....</b>	<b>11</b>
<b>5 Installation .....</b>	<b>25</b>
<b>6 Commissioning/handover.....</b>	<b>26</b>
<b>Annex A (informative) Determination of the chimney designation for custom-built and relined chimneys .....</b>	<b>27</b>
<b>Annex B (informative) List of heating appliance data required for the design of a chimney.....</b>	<b>39</b>
<b>Annex C (informative) Example of a chimney designation.....</b>	<b>40</b>
<b>Annex D (informative) Correlation between designation parameters for clay/ceramic flue liners and clay/ceramic flue blocks and concrete flue liners and concrete flue blocks.....</b>	<b>41</b>
<b>Annex E (informative) Designation of metal system chimneys and correlation between metal liner material specification and corrosion load in Member States (MS).....</b>	<b>43</b>
<b>Annex F (informative) Example of typical building structure designed to assist exchange of information .....</b>	<b>49</b>
<b>Annex G (informative) Examples of a chimney plate.....</b>	<b>52</b>
<b>Annex H (normative) Determination of a chimney designation for an installed metal system chimney .....</b>	<b>53</b>
<b>Annex I (informative) Example for the determination of the designation of a relined chimney using a metal flue liner.....</b>	<b>54</b>
<b>Annex J (informative) Example for the determination of the designation of a custom-built chimney using a clay/ceramic flue liner.....</b>	<b>60</b>
<b>Annex K (normative) Determination of the designation for an installed metal connecting flue pipe .....</b>	<b>65</b>
<b>Annex L (informative) Recommendations for inspection, cleaning and maintenance .....</b>	<b>66</b>
<b>Annex M (informative) Location of the chimney outlet .....</b>	<b>67</b>
<b>Annex N (informative) Calculating the temperature of adjacent material .....</b>	<b>71</b>
<b>Annex O (informative) Chimney commissioning .....</b>	<b>74</b>
<b>Annex P (informative) Useful hints for checking, handling and site storage of materials and components.....</b>	<b>77</b>
<b>Bibliography .....</b>	<b>79</b>

## Foreword

This document (EN 15287-1:2007+A1:2010) has been prepared by Technical Committee CEN/TC 166 "Chimneys", the secretariat of which is held by UNI.

This European Standard shall be given the status of a national standard, either by publication of an identical text or by endorsement, at the latest by February 2011, and conflicting national standards shall be withdrawn at the latest by February 2011.

This document includes Amendment 1, approved by CEN on 2010-07-28.

This document supersedes A1 EN 15287-1:2007 A1.

The start and finish of text introduced or altered by amendment is indicated in the text by tags A1 A1.

Attention is drawn to the possibility that some of the elements of this document may be the subject of patent rights. CEN [and/or CENELEC] shall not be held responsible for identifying any or all such patent rights.

This document is one of a series of specifications as listed below:

*Chimneys — Design, installation and commissioning of chimneys — Part 1: Chimneys for non-roomsealed heating appliances.*

*Chimneys — Design, installation and commissioning of chimneys — Part 2: Chimneys for roomsealed heating appliances.*

[SIST EN 15287-1:2008+A1:2010](#)

According to the CEN/CENELEC Internal Regulations, the national standards organizations of the following countries are bound to implement this European Standard: Austria, Belgium, Bulgaria, Croatia, Cyprus, Czech Republic, Denmark, Estonia, Finland, France, Germany, Greece, Hungary, Iceland, Ireland, Italy, Latvia, Lithuania, Luxembourg, Malta, Netherlands, Norway, Poland, Portugal, Romania, Slovakia, Slovenia, Spain, Sweden, Switzerland and United Kingdom.

## Introduction

CEN/TC 166 started with its programme on standardization of chimneys approximately 15 years ago, with standards for interfaces, for products, for test and last but not least for design, installation, construction and commissioning matters.

For the work program in the last years first priority had been given to product and test standards.

In the meantime most of the product and test standards are published or nearly ready to be published. In order to introduce the products, which are tested and certified in accordance with the relevant European Standards, in an easy way on the markets of the different countries, some common rules for design, installation, and commissioning especially with reference to the designation of a chimney are helpful.

Firstly CEN/TC 166/SC 2 started the work on execution standards for metal chimneys. The first standard had been already published as EN 12391-1 in 2003.

In order not to repeat this work in all material oriented WGs and SCs, CEN/TC 166 decided in 2002 to give the task to WG 1 to develop a material independent design, installation and commissioning standard.

CEN/TC 166/WG 1 started the work in 2003 and decided first to write two documents, one for chimneys connected to non-roomsealed heating appliances and one for chimneys connected to room-sealed heating appliances. Working on the documents there were two strong positions, one for a Technical Specification (TS) and one for a European Standard (EN).

Following the proposal of CEN/TC 166/WG 1, CEN/TC 166 decided to launch a vote on the question which of the two positions should apply. The CEN/TC 166 members had been in favour of creating European Standards (EN).

<https://standards.iteh.ai/catalog/standards/sist/593843d5-a1fc-425d-b174-1f29e168a2af/sist-en-15287-1-2008a1-2010>

## 1 Scope

This European Standard describes the method of specifying the design, installation criteria for system chimneys, construction of custom built chimneys, and the relining of existing chimneys. It also gives information on commissioning of chimneys.

This European Standard also deals with connecting flue pipes.

This European Standard does not apply to freestanding chimneys covered by EN 13084-1.

This European Standard excludes chimneys designated H (high positive pressure chimneys) and chimneys for room-sealed heating appliances.

For the purpose of this European Standard the term "installation" includes construction.

## 2 Normative references

The following referenced documents are indispensable for the application of this document. For dated references, only the edition cited applies. For undated references, the latest edition of the referenced document (including any amendments) applies.

EN 1443:2003, *Chimneys — General requirements*

EN 1457, *Chimneys — Clay/ceramic flue liners — Requirements and test methods*

EN 1806, *Chimneys — Clay/ceramic flue blocks for single wall chimneys — Requirements and test methods*

EN 1856-1, *Chimneys — Requirements for metal chimneys — Part 1: System chimney products*

EN 1856-2, *Chimneys — Requirements for metal chimneys — Part 2: Metal liners and connecting flue pipes*

EN 1857, *Chimneys — Components — Concrete flue liners*

EN 1858, *Chimneys — Components — Concrete flue blocks*

EN 12446, *Chimneys — Components — Concrete outer wall elements*

EN 13063-1, *Chimneys — System chimneys with clay/ceramic flue liners — Part 1: Requirements and test methods for sootfire resistance*

EN 13063-2, *Chimneys — System chimneys with clay/ceramic flue liners — Part 2: Requirements and test methods under wet conditions*

EN 13063-3, *Chimneys — System chimneys with clay/ceramic flue liners — Part 3: Requirements and test methods for air flue system chimneys*

EN 13069, *Chimneys — Clay/ceramic outer walls for system chimneys — Requirements and test methods*

EN 13084 (all parts), *Free-standing chimneys*

EN 13384-1:2002, *Chimneys — Thermal and fluid dynamic calculation methods — Part 1: Chimneys serving one appliance*

EN 13384-2, *Chimneys — Thermal and fluid dynamic calculation methods — Part 2: Chimneys serving more than one heating appliance*

**EN 15287-1:2007+A1:2010 (E)**

EN 13502, *Chimneys — Requirements and test methods for clay/ceramic flue terminals*

EN 14297, *Chimneys — Freeze-thaw resistance test method for chimney products*

EN 14471, *Chimneys — System chimneys with plastic flue liners — Requirements and test methods*

EN 14989-1, *Chimneys — Requirements and test methods for metal chimneys and material independent air supply ducts for roomsealed heating applications — Part 1: Vertical air/flue terminals for C6-type appliances*

**3 Terms and definitions**

For the purposes of this document, the terms and definitions given in EN 1443:2003 together with the following apply.

NOTE Examples of chimney construction identifying individual component terminology and definitions are given in Figures 1, 2 and 3.

**3.1 access component**  
component installed in the chimney or in the connecting flue pipe to provide access to the flue for the purpose of inspection or cleaning

**3.2 back ventilation**  
ventilation in the space between flue liner and the outer wall of the chimney or an enclosure to evacuate the products of combustion which can escape from the flue liner in positive pressure multi-wall systems

**3.3 centralising spacer**  
component to centralise the liner

**3.4 chimney adapter**  
component which connects a chimney to a connecting flue pipe or an heating appliance

**3.5 condensate drain**  
component to facilitate the disposal of condensate

**3.6 damper**  
device used to close or partially close the flue

**3.7 draught regulator**  
balanced hinged flap in a flue opening to allow airflow into the chimney to control draught at the boiler outlet

**3.8 elbow**  
chimney fitting which provides a change of direction of the flue

**3.9 explosion relief**  
device that protects the chimney against overpressure arising from deflagration or explosion in the flue

**3.10 fire compartment**  
part of the building being isolated to provide resistance to fire



**3.11****fire stop**

component intended to provide resistance to fire spread between rooms or compartments

**3.12****flashing**

component or site fabricated materials used for weatherproofing the penetration of the roof by the chimney

**3.13****flexible liner**

tube having a single or multi-skin construction that is able to bend in any direction without permanent deformation

**3.14****heating appliance adapter**

component which connects the connecting flue pipe or the chimney to a heating appliance

**3.15****rain cap**

part of the chimney that protects against the entry of rain. This can be a part of a terminal

**3.16****rigid liner**

straight liner that cannot bend without permanent deformation

**3.17****rain seal**

part of the chimney that stops the entry of rain into the insulation space

**3.18****seal**

device that joins two elements in such a way as to prevent leakage

**3.19****sealant**

material which, applied in an unformed state to a joint, seals it by adhering to appropriate surfaces within the joint

**3.20****silencer**

component installed to provide noise attenuation

**3.21****sleeve**

component which provides an aperture through a wall, ceiling or floor through which a chimney or a connecting flue pipe passes

**3.22****test point**

component that provides access for flue gas sampling and measurement

**3.23****T-piece**

chimney fitting which allows a heating appliance, connecting flue pipe or accessory to be connected to the chimney flue at an angle

iTeh STANDARD PREVIEW  
(standards.iteh.ai)

SIST EN 15287-1:2008+A1:2010

<https://standards.iteh.ai/catalog/standards/sist/593843d5-a1fc-425d-b174-1f29e168a2a7/sist-en-15287-1-2008a1-2010>

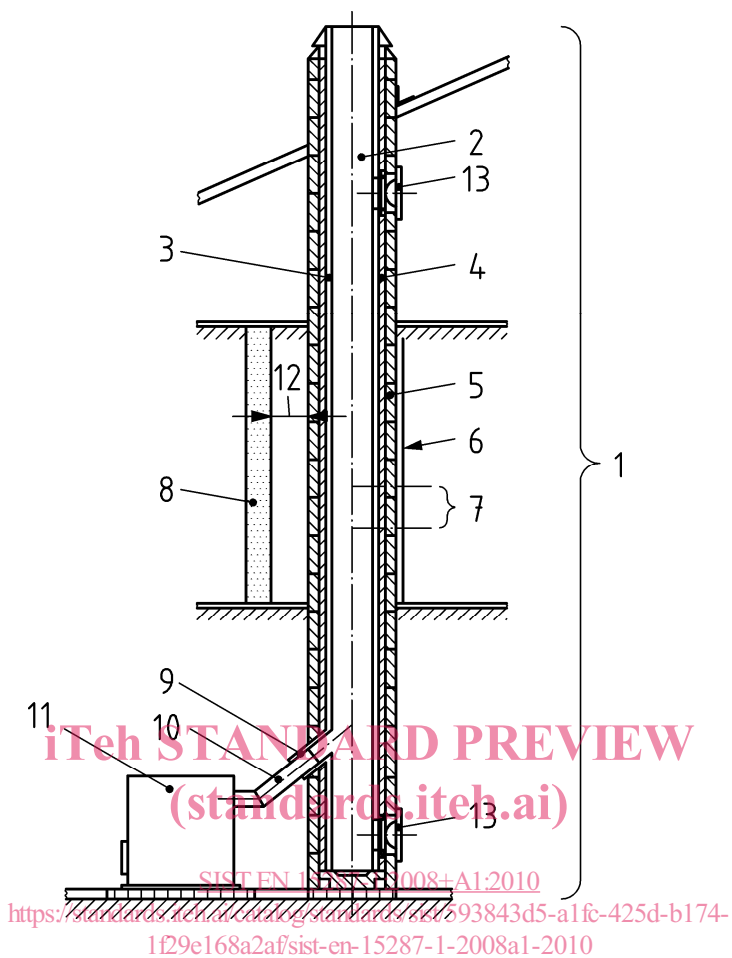
**Key**

1	chimney	7	chimney section
2	flue	8	adjacent combustible wall or enclosure or cladding
3	flue liner	9	chimney fitting
4	thermal insulation	10	connecting flue pipe
5	outer wall	11	heating appliance
6	non-combustible enclosure or cladding	12	distance to combustible material
		13	access component

**Figure 1 — Chimney components and chimney accessories of a multi-wall chimney**

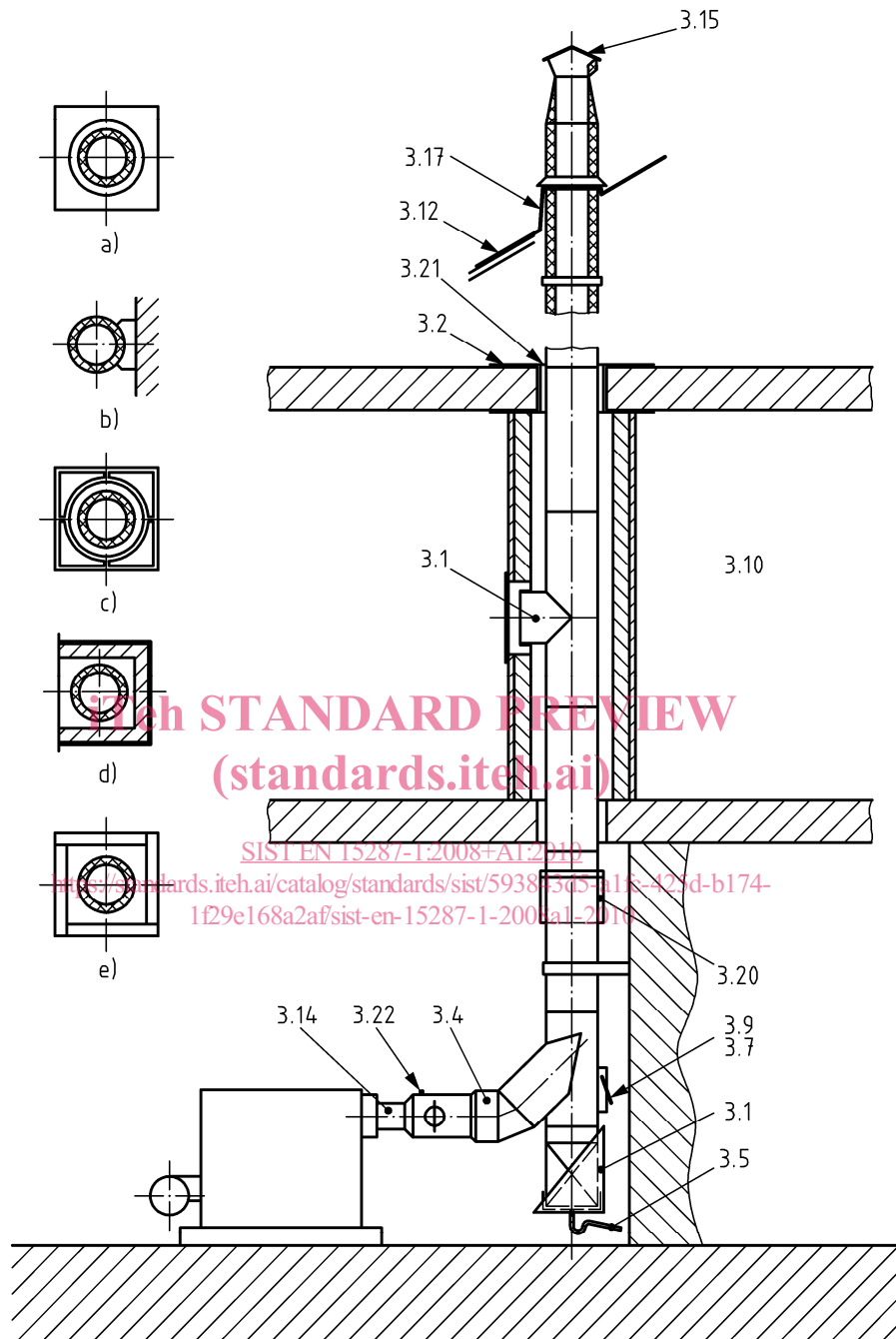
**Key**

see Clause 3

- a chimney in a solid block shaft
- b internal or external chimney without enclosure
- c chimney in a cavity block
- d chimney in a shaft or an enclosure as a part of the building structure
- e chimney in a separate enclosure

**Figure 2 — Terminology for a system chimney**

NOTE The liner may be of clay, concrete, metal or plastic.

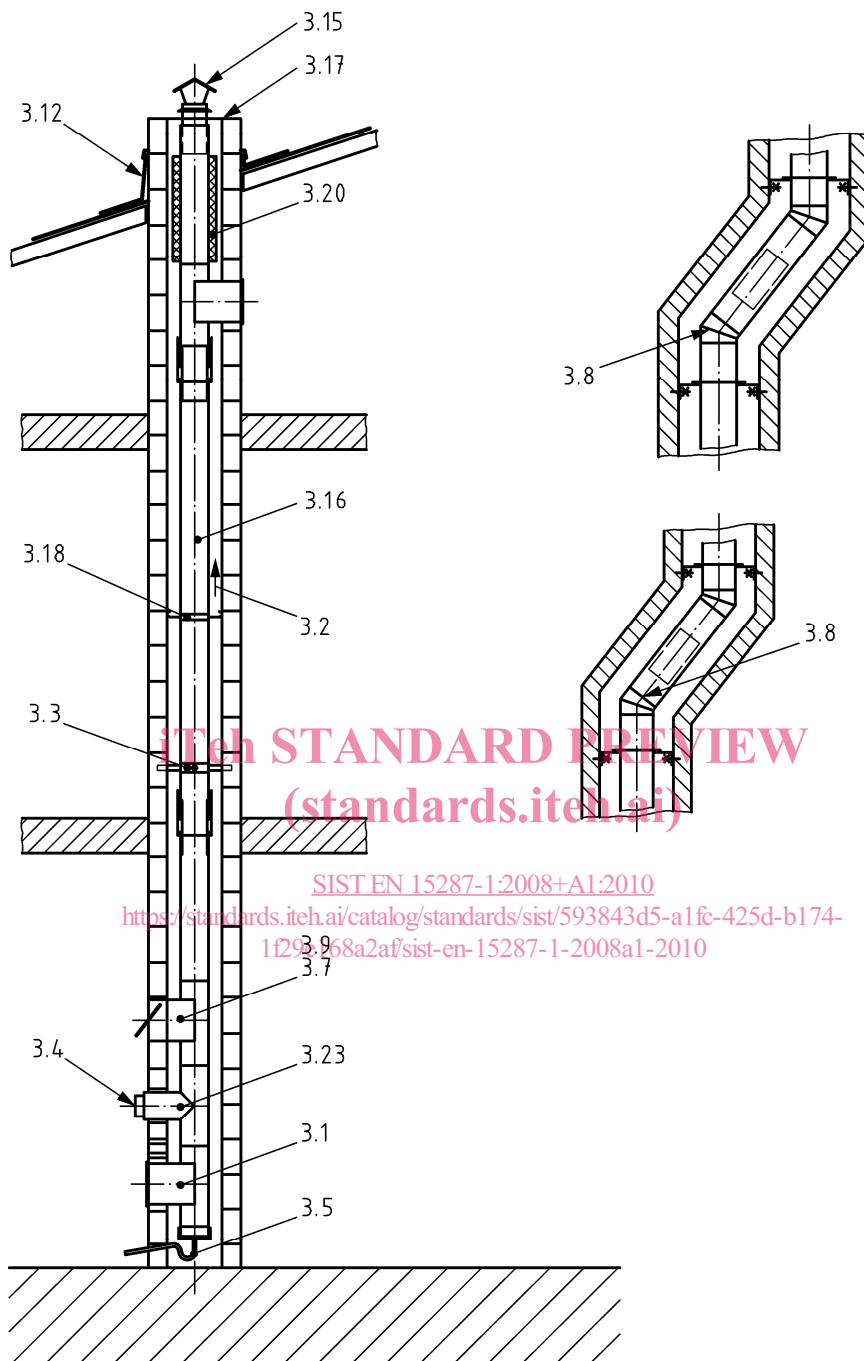

**Key**  
see Clause 3

**Figure 3 — Terminology for a custom-built or a relined chimney**

NOTE The liner may be of clay, concrete, metal or plastic.

## 4 Design

### 4.1 General

In order to design a chimney installation the following steps should be followed to achieve a safe chimney installation.

Chimneys shall comply with national regulations and nationally accepted rules.

### 4.2 Data requirements

#### 4.2.1 Sources of data and information

The data and information specified in 4.2.2 to 4.2.6 shall be obtained and documented as appropriate.

NOTE The sources can be:

- heating appliance manufacturers catalogues and literature;
- chimney manufacturers literature including installation instructions;
- architects drawings or plans and/or site surveys;
- local building rules.

A possible source of typical or average data is in Annex A and in EN 13384-1.

<https://standards.iteh.ai/catalog/standards/sist/593843d5-a1fc-425d-b174-3a2af/sist-en-15287-1-2008a1-2010>

#### 4.2.2 Heating appliance information

The information for the heating appliance(s) (see Annex B for an example) shall be obtained from the documentation of the heating appliance manufacturer or if not available, default values may be used (see EN 13384-1:2002, Annex B), but the source of the data shall be documented in the design (see 4.2.1).

#### 4.2.3 Chimney product specification

The following information about the chimney product specification shall be obtained (see 4.2.1):

- identification and designation of the system chimney or of the components for custom built chimneys or for relining an existing chimney, see also Annex C, Annex D and Annex E;
- design load or maximum allowed chimney height to be supported by lengths, fittings and supports;
- mass of components;
- manufacturer's installation instruction;
- additional information for chimney sizing (see EN 13384-1).

**EN 15287-1:2007+A1:2010 (E)****4.2.4 Building construction and chimney route information**

In order to allow the chimney route to be determined the relevant details of the building or support structure shall be obtained (see Figure F.1).

If the chimney is to be supported by the building structure, the construction of the building and the materials used shall be capable of supporting the loads imposed upon it by the chimney. The fixings shall be compatible with the materials of construction of the building. This shall be checked before installing the chimney.

A check list of information is given in Annex F.

**4.2.5 Local conditions**

Environmental and topographical particulars of the site shall be obtained.

**4.2.6 Combustion air supply**

Information on the size and position of apertures for combustion air supply into the room containing the heating appliance shall be obtained (possible sources of data are given in 4.2.1).

**4.3 Design requirements****4.3.1 General**

The design of the chimney installation shall be detailed and documented. Manufacturers' product information may fulfil this requirement. The design should enable a chimney product manufacturer's standard components to be used in carrying out the installation. Modification of components, e.g. producing openings or adjustments of length may only be undertaken in accordance with the manufacturer's instructions.

NOTE The finished chimney should have a designation in accordance with EN 1443 (see Annex C). The chimney products should be chosen so that the designation reflects the suitability of the chimney for the intended use. Annex E gives an example for the designation of a metal system chimney and Annex A gives an example of the general designation of a chimney according EN 1443. The finished chimney should have a chimney plate (see Annex G).

**4.3.2 Designation**

The chimney and connecting flue pipe shall have designation classes appropriate to the heating appliance data as required in 4.2.2 and the building structure data as required in 4.2.4.

The connecting flue pipe may have a designation different from that of the chimney i.e. where the heating appliance output results in a positive pressure in the connecting flue pipe.

Each designation parameter shall be of a class at least equal to that required or shall be of a higher class according to the following sequence:

- T600 > T450 > T400 > T300 > T250 > T200 > T160 > T140 > T120 > T100 > T080;
- $H > P > N$ ;
- $Wx > Dx$ ;
- $D3 > D2 > D1$ ;
- $W3 > W2 > W1$ ;
- $G > O$ ;

where

- T* is the temperature class;
- P* is the positive pressure class;
- N* is the negative pressure class;
- O* is without soot fire resistance;
- G* is with soot fire resistance;
- xx* is the distance to combustibles;

and for corrosion class:

- W* is wet operating conditions;
- D* is dry operating conditions;
- 1 is for gas and kerosene with a sulphur content  $\leq 50 \text{ mg/m}^3$ ;
- 2 is for light oil / wood in open fires;
- 3 is for heavy oil / wood in closed stoves / coal and peat.

#### 4.3.3 Determination of designation of the chimney and connecting flue pipe (standards.itteh.ai)

##### 4.3.3.1 General

The chimney shall be assigned designations according to EN 1443 (see Annex C).

##### 4.3.3.2 System chimney

The designation of an installed system chimney shall be according to the product standard EN 13063-1 and EN 13063-2 for clay/ceramic products and EN 1858 for concrete products.

The designation of an installed metal system chimney according to EN 1856-1 shall be according to Annex H.

The designation of an installed plastic system chimney shall be according to the product standard EN 14471 excluding the location, reaction to fire and enclosure parameters.

##### 4.3.3.3 Custom-built and relined chimney

The designation of a custom-built or a relined chimney shall be determined. The methods to determine the designation is according to the calculations of Annex A or according to national regulations or nationally accepted rules.

The temperature class, the sootfire class and the distance to combustible material given in the designation of a chimney product may be used for the custom-built chimney designation.

NOTE Examples for the determination of the designation of relined and custom built chimneys are given in Annex I and Annex J.