



Designation: D 1796 – 97

An American National Standard



Designation: MPMS Chapter 10.6

Standard Test Method for Water and Sediment in Fuel Oils by the Centrifuge Method (Laboratory Procedure)¹

This standard is issued under the fixed designation D 1796; the number immediately following the designation indicates the year of original adoption or, in the case of revision, the year of last revision. A number in parentheses indicates the year of last reapproval. A superscript epsilon (ϵ) indicates an editorial change since the last revision or reapproval.

This test method has been approved by the sponsoring committees and accepted by the cooperating organizations in accordance with established procedures. This test method has been adopted for use by government agencies to replace Method 3000 of Federal Test Method Standard No. 7916.

1. Scope

1.1 This test method covers the laboratory test for determination of water and sediment in fuel oils by using the centrifuge method in the range from 0 to 30 % volume. This chapter, along with API Chapter 10.3 (Test Method D 4007, IP 359), supersedes the previous edition of Test Method D 1796 (API Standard D 2548, IP 75).

NOTE 1—With some types of fuel oils such as residual fuel oils or distillate fuel oils containing residual components, it is difficult to obtain water or sediment contents with this test method. When this situation is encountered, Method D 95 (API MPMS Chapter 10.5) or Test Method D 473 (API MPMS Chapter 10.1) may be used.

1.2 Annex A2 contains a procedure for saturating toluene with water.

1.3 The values stated in SI units are to be regarded as the standard. The values in parentheses are for information only.

1.4 *This standard does not purport to address all of the safety concerns, if any, associated with its use. It is the responsibility of the user of this standard to establish appropriate safety and health practices and determine the applicability of regulatory limitations prior to use.* For a specific precautionary statement see 6.1.

2. Referenced Documents

2.1 ASTM Standards:

D 95 Test Method for Water in Petroleum Products and Bituminous Materials by Distillation (API MPMS Chapter 10.5)²

D 362 Specification for Industrial Grade Toluene³

D 473 Test Method for Sediment in Crude Oils and Fuel

Oils by the Extraction Method²

D 4006 Test Method for Water in Crude Oil by Distillation⁴

D 4007 Test Method for Water and Sediment in Crude Oil by the Centrifuge Method (Laboratory Procedure)⁴

D 4057 Practice for Manual Sampling of Petroleum and Petroleum Products⁴

D 4177 Practice for Automatic Sampling of Petroleum and Petroleum Products⁴

D 4377 Test Method for Water in Crude Oils by Volumetric Karl Fischer Titration⁴

D 4928 Test Method for Water in Crude Oils by Coulometric Karl Fischer Titration⁵

D 5854 Practice for Mixing and Handling Liquid Samples of Petroleum and Petroleum Products⁵

E 542 Practice for Calibration of Laboratory Volumetric Apparatus⁶

2.2 *API Manual of Petroleum Measurement Standards:*⁷

Chapter 8.1, Manual Sampling of Petroleum and Petroleum Products (Practice D 4057)

Chapter 8.2, Automatic Sampling of Petroleum and Petroleum Products (Test Method D 4177)

Chapter 8.3, Mixing and Handling Liquid Samples of Petroleum and Petroleum Products (Test Method D 5854)

Chapter 10.1, Determination of Sediment in Crude Oil by the Extraction Method (Test Method D 473)

Chapter 10.2, Determination of Water in Crude Oil by the Distillation Method (Test Method D 4006)

Chapter 10.3, Determination of Water and Sediment in Crude Oils by the Centrifuge Method (Laboratory Procedure) (Test Method D 1796)

Chapter 10.5, Determination of Water in Petroleum Products and Other Bituminous Materials (Test Method D 95)

¹ This test method is under the jurisdiction of ASTM Committee D02 on Petroleum Products and Lubricants and is the direct responsibility of Subcommittee D02.02 on Static Petroleum Measurement.

Current edition approved Jan. 10, 1997. Published October 1997. Originally published as D 1796 – 60. Last previous edition D 1796 – 83 (1990). ⁴¹

² *Annual Book of ASTM Standards*, Vol 05.01.

³ *Discontinued*—See 1988 *Annual Book of ASTM Standards*, Vol 06.03.

⁴ *Annual Book of ASTM Standards*, Vol 05.02.

⁵ *Annual Book of ASTM Standards*, Vol 05.03.

⁶ *Annual Book of ASTM Standards*, Vol 14.02.

⁷ Available from the American Petroleum Institute, 1220 L St., N.W., Washington, DC 20005.

Chapter 10.7, Determination of Water in Crude Oils (Karl Fischer) Titration (Test Method D 4377)

Chapter 10.9, Determination of Water in Crude Oils Coulometric Karl Fischer Titration (Test Method D 4928)

2.3 *IP Standard*:⁸

Specification for Toluol

3. Summary of Test Method

3.1 Equal volumes of fuel oil and water saturated toluene are placed in each of two cone-shaped centrifuge tubes. After centrifugation, the volume of the higher gravity water and sediment layer at the bottom of the tube is read.

4. Significance and Use

4.1 The water and sediment content of fuel oil is significant because it can cause corrosion of equipment and problems in processing. The water and sediment content must be known to measure accurately net volumes of actual fuel oil in sales, taxation, exchanges, and custody transfers.

5. Apparatus

5.1 *Centrifuge*:

5.1.1 A centrifuge capable of spinning two or more filled cone-shaped 203-mm (8-in.) centrifuge tubes at a speed which can be controlled to give a relative centrifugal force (rcf) of between 500 and 800 at the tip of the tubes shall be used.

5.1.2 The revolving head, trunnion rings, and trunnion cups, including the cushions, shall be soundly constructed to withstand the maximum centrifugal force capable of being delivered by the power source. The trunnion cups and cushions shall firmly support the tubes when the centrifuge is in motion. The centrifuge shall be enclosed by a metal shield or case strong enough to eliminate danger if any breakage occurs.

5.1.3 Calculate the speed of the rotating head in revolutions per minute (rpm) as follows:

$$rpm = 1335 \sqrt{rcf/d} \quad (1)$$

where:

rcf = relative centrifugal force, and

d = diameter of swing, mm measured between tips of opposite tubes when in rotating position.

or

$$rpm = 265 \sqrt{rcf/d} \quad (2)$$

where:

rcf = relative centrifugal force, and

d = diameter of swing (inches) measured between tips of opposite tubes when in rotating position.

5.2 *Centrifuge Tubes*:

5.2.1 Each centrifuge tube shall be a 203-mm (8-in.) cone-shaped tube, conforming to the dimensions given in Fig. 1 and made of thoroughly annealed glass. The graduations, numbered as shown in Fig. 1, shall be clear and distinct, and the mouth shall be constricted in shape for closure with a cork or solvent-resistant rubber stopper. Scale error tolerances and the

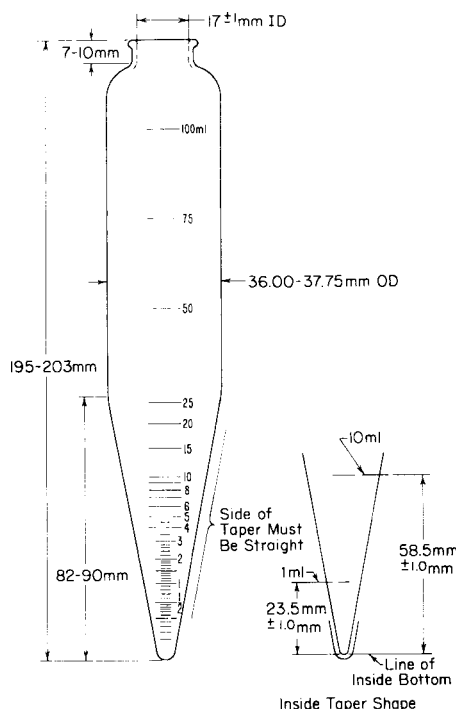

FIG. 1 Eight-Inch (203-mm) Centrifuge Tube

smallest graduations between various calibration marks are given in Table 1 and apply to calibrations made with air-free water at 20°C (68°F), when reading the bottom of the shaded meniscus.

5.2.2 The accuracy of the graduation marks shall be volumetrically verified or gravimetrically certified, in accordance with Practice E 542 using equipment traceable through the National Institute of Standards and Technology (NIST).⁹ The verification or certification shall include verification for each mark through the 0.5-mL mark; of the 1, 1.5 and 2-mL marks; and of the 50 and 100-mL marks. The tube shall not be used if the scale error exceeds the applicable tolerance in Table 1.

5.3 *Bath*—The bath shall be either a solid metal block bath or a liquid bath of sufficient depth for immersing the centrifuge tube in the vertical position to the 100-mL mark. Means shall be provided for maintaining the temperature at 49 ± 1°C (120 ± 2°F) and 60 ± 1°C (140 ± 2°F). See Note 2.

⁹ Available from National Institute of Standards and Technology, Gaithersburg, MD 20899.

TABLE 1 Centrifuge Tube Calibration Tolerances for 8-in. (203-mm) Tube

Range, mL	Subdivision, mL	Volume Tolerance, mL
0 to 0.1	0.05	±0.02
Above 0.1 to 0.3	0.05	±0.03
Above 0.3 to 0.5	0.05	±0.05
Above 0.5 to 1.0	0.10	±0.05
Above 1.0 to 2.0	0.10	±0.10
Above 2.0 to 3.0	0.20	±0.10
Above 3.0 to 5.0	0.50	±0.20
Above 5.0 to 10	1.00	±0.50
Above 10 to 25	5.00	±1.00
Above 25 to 100	25.00	±1.00

⁸ Available from American National Standards Institute, 11 W. 42nd Street., 13th Floor, New York, NY 10036.

6. Reagents

6.1 *Toluene* (**Warning**—Flammable vapor harmful. See Annex A1.) that conforms to Specification D 362 or to the IP Specification for Toluol shall be used as the solvent.

6.1.1 The toluene shall be water saturated at $60 \pm 3^\circ\text{C}$ ($140 \pm 5^\circ\text{F}$), but shall be free of suspended water. This may be accomplished by the addition of 2 mL of water per 1000 mL of solvent. Shaking will aid in saturation, but adequate settling time is necessary to ensure that the solvent is free of suspended water before use. See Annex A2 for a procedure for saturating toluene with water.

NOTE 2—It has been observed for some fuel oils that temperatures higher than 60°C (140°F) may be required to obtain correct sediment and water content. If temperatures higher than 60°C are necessary, they may be used only with the consent of the parties involved. Water saturation of toluene may also be done at this higher testing temperature. (See Appendix X1.)

NOTE 3—Some oils may require other solvents or solvent-demulsifier combinations. Those agreed upon between the purchaser and the seller may be used.

6.2 Demulsifiers:

6.2.1 Where necessary, a demulsifier should be used to promote the separation of water from the sample, to prevent water from clinging to the walls of the centrifuge tube and to enhance the distinctness of the water-oil interface.

6.2.2 When a demulsifier is used, it should be mixed according to the manufacturer's recommendations and should never be added to the volume of sediment and water determined. The demulsifier should always be used in the form of a demulsifier-solvent stock solution or be premixed with the solvent to be used in the test.

7. Sampling

7.1 Sampling is defined as all steps required to obtain an aliquot of the contents of any pipe, tank, or other system and to place them into the laboratory test container. Only representative samples obtained as specified in Test Method D 4057 (API Chapter 8.1) and (Test Method D 4177) (API Chapter 8.2) shall be used for this test method.

7.2 Practice D 5854 contains additional information on sampling and homogenization efficiency of an untested mixer. This test method should not be attempted without strict adherence to Practice D 5854.

8. Procedure

8.1 Fill each of two centrifuge tubes to the 50-mL mark with the well-mixed sample directly from the sample container. Then, using a pipette, add 50 mL of the water-saturated solvent. Read the top of the meniscus at both the 50 and 100-mL marks. Stopper the tubes tightly and shake vigorously until the contents are thoroughly mixed. Loosen the stoppers on the tubes and immerse the tubes to the 100-mL mark for 10 min in the bath maintained at $60 \pm 1^\circ\text{C}$ ($140 \pm 2^\circ\text{F}$).

8.2 Tighten the stoppers and again invert the tubes to ensure that the oil and solvent are uniformly mixed and shake cautiously.

NOTE 4—**Warning:** In general, the vapor pressures of hydrocarbons at 60°C (140°F) are approximately double those at 40°C (104°F). Consequently, tubes should always be inverted at a position below eye level so

that contact will be avoided if the stopper is blown out.

8.2.1 Place the tubes in the trunnion cups on opposite sides of the centrifuge to establish a balanced condition, and spin for 10 min at a rate, calculated from the equation given in 5.1, sufficient to produce a relative centrifugal force (*rcf*) of between 500 and 800 at the tip of the whirling tubes (see Table 2 for the relationship between diameter of swing, relative centrifugal force, and revolutions per minute). The temperature of the sample during the entire centrifuging procedure shall be maintained at $60 \pm 1^\circ\text{C}$ ($140 \pm 2^\circ\text{F}$). (See Note 2.)

8.2.2 Immediately after the centrifuge comes to rest following the spin, read and record the combined volume of water and sediment at the bottom of each tube to the nearest 0.05 mL from 0.1 to 1-mL graduations and to the nearest 0.1 mL above the 1-mL graduations. Below 0.1 mL estimate to the nearest 0.025 mL (see Fig. 2). If less than 0.025 mL of water and sediment is visible and it is not a great enough volume to be considered 0.025 mL, record the volume as less than 0.025 mL. If no water or sediment is visible, record the volume as 0.000 mL. Return the tubes without agitation to the centrifuge and spin for another 10 min. at the same rate.

8.2.3 Repeat this operation until the combined volume of water and sediment remains constant for two consecutive readings. In general, not more than two spinings are required.

8.2.4 If the difference between the final volumes is not greater than one subdivision on the centrifuge tube (see Table 1), or, for estimated volumes of 0.10 mL or lower, proceed with the calculation of water and sediment content using Eq 3 as described in Section 9. If the difference is greater than one subdivision or, for readings of 0.10 or below, greater than 0.025 mL, the readings are inadmissible and the determination shall be repeated starting at 8.1.

9. Calculation

9.1 Record the final volume of water and sediment in each tube and report the sum of these two readings as the percentage of sediment and water. Report results lower than 0.05 % either as 0 or 0.05, whichever is closer.

9.2 Calculate the water and sediment of the sample as follows:

TABLE 2 Rotation Speeds Applicable for Centrifuges of Various Diameters of Swing

NOTE 1—*rcf* = relative centrifugal force.

Diameter of Swing		Revolutions per Minute	
Millimetres	Inches ^A	At 500 <i>rcf</i>	At 800 <i>rcf</i>
305	12	1710	2170
330	13	1650	2010
356	14	1590	2000
381	15	1530	1930
406	16	1490	1870
432	17	1440	1820
457	18	1400	1770
483	19	1360	1720
508	20	1330	1680
533	21	1300	1640
559	22	1270	1600
584	23	1240	1560
610	24	1210	1530

^AFor this column, the diameter of swing is measured in inches between tips of opposite tubes when in rotating position.