



## SLOVENSKI STANDARD

SIST EN 848-1:2007+A1:2010/kFprA2:2012

01-junij-2012

---

### Varnost lesnoobdelovalnih strojev - Rezkalniki z vrtečim orodjem za enostransko obdelavo - 1. del: Enovretenski vertikalni rezkalni stroji - Dopolnilo A2

Safety of woodworking machines - One side moulding machines with rotating tool - Part 1: Single spindle vertical moulding machines

Sicherheit von Holzbearbeitungsmaschinen - Fräsmaschinen für einseitige Bearbeitung mit drehendem Werkzeug - Teil 1: Einspindelige senkrechte Tischfräsmaschinen

Sécurité des machines pour le travail du bois - Machines à fraiser sur une face à outil rotatif - Partie 1 : Toupies monobroche à arbre vertical

**Ta slovenski standard je istoveten z: EN 848-1:2007+A1:2009/FprA2**

---

#### **ICS:**

79.120.10      Lesnoobdelovalni stroji      Woodworking machines

**SIST EN 848-  
1:2007+A1:2010/kFprA2:2012**

**en,fr,de**



EUROPEAN STANDARD  
NORME EUROPÉENNE  
EUROPÄISCHE NORM

**FINAL DRAFT**  
**EN 848-1:2007+A1:2009**  
**FprA2**

April 2012

---

ICS 79.120.10

English Version

## Safety of woodworking machines - One side moulding machines with rotating tool - Part 1: Single spindle vertical moulding machines

Sécurité des machines pour le travail du bois - Machines à  
fraisier sur une face à outil rotatif - Partie 1 : Toupies  
monobroche à arbre vertical

Sicherheit von Holzbearbeitungsmaschinen -  
Fräsmaschinen für einseitige Bearbeitung mit drehendem  
Werkzeug - Teil 1: Einspindelige senkrechte  
Tischfräsmaschinen

This draft amendment is submitted to CEN members for unique acceptance procedure. It has been drawn up by the Technical Committee CEN/TC 142.

This draft amendment A2, if approved, will modify the European Standard EN 848-1:2007+A1:2009. If this draft becomes an amendment, CEN members are bound to comply with the CEN/CENELEC Internal Regulations which stipulate the conditions for inclusion of this amendment into the relevant national standard without any alteration.

This draft amendment was established by CEN in three official versions (English, French, German). A version in any other language made by translation under the responsibility of a CEN member into its own language and notified to the CEN-CENELEC Management Centre has the same status as the official versions.

CEN members are the national standards bodies of Austria, Belgium, Bulgaria, Croatia, Cyprus, Czech Republic, Denmark, Estonia, Finland, France, Germany, Greece, Hungary, Iceland, Ireland, Italy, Latvia, Lithuania, Luxembourg, Malta, Netherlands, Norway, Poland, Portugal, Romania, Slovakia, Slovenia, Spain, Sweden, Switzerland, Turkey and United Kingdom.

Recipients of this draft are invited to submit, with their comments, notification of any relevant patent rights of which they are aware and to provide supporting documentation.

**Warning** : This document is not a European Standard. It is distributed for review and comments. It is subject to change without notice and shall not be referred to as a European Standard.



EUROPEAN COMMITTEE FOR STANDARDIZATION  
COMITÉ EUROPÉEN DE NORMALISATION  
EUROPÄISCHES KOMITEE FÜR NORMUNG

**Management Centre: Avenue Marnix 17, B-1000 Brussels**

## Contents

Page

Foreword.....	4
1 General.....	5
2 Modifications to Clause 1, Scope.....	5
3 Modifications to Clause 2, Normative references .....	5
4 Modifications to 3.2, Definitions.....	6
4 Modifications to 3.3, Terminology.....	8
5 Modifications to Clause 4, List of significant hazards.....	8
6 Modifications to 5.1, General.....	12
7 Modifications to 5.2.1.1, General.....	12
8 Modifications to 5.2.1.2, Use of well tried components and protective devices.....	12
9 Modification to 5.2.3, Starting.....	13
10 Modifications to 5.2.4, Normal stopping .....	13
11 Modifications to 5.2.5, Emergency stop .....	13
12 Modification to 5.2.6, Mode selection .....	13
13 Modifications to 5.2.7.1, General.....	13
14 Modification to 5.2.7.2, Speed limiting device for tenoning .....	14
15 Modification to 5.2.8.1, Power driven adjustments under hold-to-run control .....	14
16 Modifications to 5.2.8.2, Automatic power driven adjustments.....	14
17 Modification to 5.3.3.3, Dimensions for spindle and tools .....	15
18 Modification to 5.3.3.4.1, Manual height adjustment.....	15
19 Modification to 5.3.3.6, Direction of rotation.....	15
20 Modification to 5.3.4.1, General.....	15
21 Modifications to 5.3.4.2, Brake release.....	16
22 Modification to 5.3.6.2.1, Fence plate dimensions .....	16
23 Modifications to 5.3.7.1.1, Safeguarding under the table .....	16
24 Modification to 5.3.7.1.2.1, Safeguarding the cutting area .....	17
25 Modification to 5.3.7.1.2.2, Safeguarding the non-cutting area .....	17
26 Modification to 5.3.7.1.4.2, Safeguarding the cutting area .....	17
27 Modification to 5.3.7.1.5, Safeguarding the glass bead saw blade.....	17
28 Modifications to 5.3.7.2, Guarding of drives .....	17
29 Modifications to 5.3.7.3, Characteristics of guards.....	18
30 Modification to 5.3.8, Workpiece clamping device.....	18
31 Modifications of 5.4.2.2, Noise emission measurement .....	18
32 Modifications to 5.4.3, Emission of chips and dust .....	18

33	Modifications to 5.4.4, Electricity.....	19
34	Modification to 5.4.8, Electromagnetic compatibility .....	19
35	Modification to 6.3, Instruction handbook.....	19
36	Modification to Annex D .....	20
38	Deletion of Annex F.....	23
39	Deletion of Annex ZA .....	23
40	Modifications to Annex ZB .....	23
41	Modification to Bibliography.....	23

**EN 848-1:2007+A1:2009/FprA2:2012 (E)**

**Foreword**

This document (EN 848-1:2007+A1:2009/FprA2:2012) has been prepared by Technical Committee CEN/TC 142 "Woodworking machines - Safety", the secretariat of which is held by UNI.

This document is currently submitted to the Unique Acceptance Procedure.

This document has been prepared under a mandate given to CEN by the European Commission and the European Free Trade Association, and supports essential requirements of the Machinery Directive.

For relationship with EU Directive(s), see informative Annex ZA, which is an integral part of this document.

## 1 General

Replace throughout the text "travelling" with "sliding".

## 2 Modifications to Clause 1, Scope

Add at the end of 1<sup>st</sup> paragraph: "including reasonably foreseeable misuse".

Add after 1<sup>st</sup> paragraph: "Machines which are designed to work wood based materials may also be used for working hardened plastic materials with similar physical characteristics as wood".

## 3 Modifications to Clause 2, Normative references

Add the following references:

"EN 847-3:2004, *Tools for woodworking — Safety requirements — Part 3: Clamping devices*",

"EN 61800-5-2:2007, *Adjustable speed electrical power drive systems — Part 5-2: Safety requirements — Functional (IEC 61800-5-2:2007)*",

"EN ISO 4413:2010, *Hydraulic fluid power — General rules and safety requirements for systems and their components (ISO 4413:2010)*

EN ISO 4414:2010, *Pneumatic fluid power — General rules and safety requirements for systems and their components (ISO 4414:2010)*".

Delete reference to EN 982:1996, EN 983:1996, EN 61508-3:2001 and EN 62061:2005.

Delete reference to EN ISO 11202:1995/AC:1997, EN ISO 11204:1995/AC 1997 and EN ISO 11688-1:1998/AC:1998.

Replace "EN ISO 3743-1:1995" with "EN ISO 3743-1:2010" and replace the title with "Acoustics — Determination of sound power levels and sound energy levels of noise sources using sound pressure — Engineering methods for small movable sources in reverberant fields — Part 1: Comparison method for a hard-walled test room (ISO 3743-1:2010)".

Replace "EN ISO 3744:1995" with "EN ISO 3744:2010" and replace the title with "Acoustics — Determination of sound power levels and sound energy levels of noise sources using sound pressure — Engineering methods for an essentially free field over a reflecting plane (ISO 3744:2010)".

Replace "EN ISO 3746:1995" with "EN ISO 3746:2010" and replace the title with "Acoustics — Determination of sound power levels and sound energy levels of noise sources using sound pressure — Survey method using an enveloping measurement surface over a reflecting plane (ISO 3746:2010)".

Replace "EN ISO 11202:1995" with "EN ISO 11202:2010" and replace the title with "Acoustics — Noise emitted by machinery and equipment — Determination of emission sound pressure levels at a work station and at other specified positions applying approximate environmental corrections (ISO 11202:2010)".

Replace "EN ISO 11204:1995" with "EN ISO 11204:2010" and replace the title with "Acoustics — Noise emitted by machinery and equipment — Determination of emission sound pressure levels at a work station and at other specified positions applying accurate environmental corrections (ISO 11204:2010)".

Replace "EN ISO 12100-1:2003" and "EN ISO 12100-2:2003" with "EN ISO 12100:2010, *Safety of machinery — General principles for design — Risk assessment and risk reduction (ISO 12100:2010)*".

**EN 848-1:2007+A1:2009/FprA2:2012 (E)**

*Replace throughout the standard reference to:*

"EN 847-1:2005" with "EN 847-1:2005+A1:2007",

"EN 894-1:1997" with "EN 894-1:1997+A1:2008",

"EN 894-2:1997" with "EN 894-2:1997+A1:2008",

"EN 894-3:2000" with "EN 894-3:2000+A1:2008",

"EN 982:1996" with "EN ISO 4413:2010",

"EN 983:1996" with "EN ISO 4414:2010",

"EN 1005-1:2001" with "EN 1005-1:2001+A1:2008",

"EN 1005-2:2003" with "EN 1005-2:2003+A1:2008",

"EN 1005-3:2002" with "EN 1005-3:2002+A1:2008",

"EN 1005-4:2005" with "EN 1005-4:2005+A1:2008",

"EN 1037:1995" with "EN 1037:1995+A1:2008",

"EN 1088:1995" with "EN 1088:1995+A2:2008",

"EN 60439-1:1999" with "EN 60439-1:1999 and EN 60439-1:1999/A1:2004" in the text excluding Clause 2,

"EN 60529:1991" with "EN 60529:1991 and EN 60529:1991/A1 2000" in the text excluding Clause 2,

"EN ISO 3743-1:1995" with "EN ISO 3743-1:2010",

"EN ISO 3743-2:1996" with "EN ISO 3743-2:2009",

"EN ISO 3744:1995" with "EN ISO 3744:2010",

"EN ISO 3745:2003" with "EN ISO 3745:2009",

"EN ISO 3746:1995" with "EN ISO 3746:2010",

"EN ISO 4871:1996" with "EN ISO 4871:2009",

"EN ISO 9614-1:1995" with "EN ISO 9614-1:2009",

"EN ISO 11202:1995" with "EN ISO 11202:2010",

"EN ISO 11204:1995" with "EN ISO 11204:2010",

"EN ISO 11688-1:1998" with "EN ISO 11688-1:2009",

"EN ISO 12100-1:2003" and "EN ISO 12100-2:2003" with "EN ISO 12100:2010" and

"EN ISO 13850:2006" with "EN ISO 13850:2008".

**4 Modifications to 3.2, Definitions**

*Replace Figure 5 with the following Figure 5. In the key delete 10 and 11 and replace 8 and 9 with:*



"8 fence  
9 feed direction".  
"

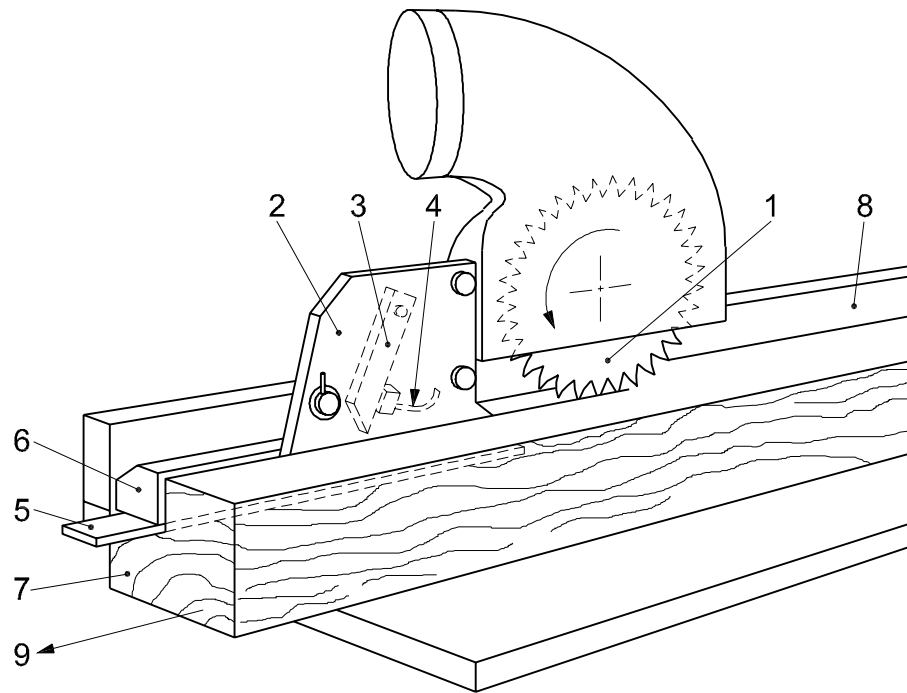

Delete definition 3.2.19 and renumber accordingly.

In new 3.2.19, replace the definition with:

"software that is part of the system supplied by the control manufacturer and which is not accessible for modification by the user of the machinery",

and in NOTE 1, replace "(see 3.2.47 of EN 62061:2005)" with "(3.1.37 of EN ISO 13849-1:2008)" to read:

"NOTE 1 Firmware or system software are examples of embedded software (EN ISO 13849-1:2008, 3.1.37)."

In new 3.2.20, replace the definition and the Note with:

"software specific to the application, implemented by the machine manufacturer, and generally containing logic sequences, limits and expressions that control the appropriate inputs, outputs, calculations and decisions necessary to meet the SRP/CS requirements

[EN ISO 13849-1:2008, 3.1.36]".

Add the following terms and definitions:

### **"3.2.21**

#### **safety related part of a control system (SRP(CS))**

part or subpart(s) of a control system that responds to input signals and generates safety-related output signals

NOTE 1 The combined safety-related parts of a control system start at the point where the safety-related signals are initiated (including e.g. the actuating cam and the roller of the position switch) and end at the output of the power control elements (including e.g. the main contacts of the contactor). This also includes monitoring systems (EN ISO 13849-1:2008, 3.1).

**EN 848-1:2007+A1:2009/FprA2:2012 (E)****3.2.22****performance level PL**

discrete level used to specify the ability of safety-related parts of control systems to perform a safety function under foreseeable conditions

[EN ISO 13849-1:2008, 3.1.23]".

**4 Modifications to 3.3, Terminology**

*In the title of Figure 6 c) replace "with transparent adjustable guards" with "with transparent adjustable guard and adjustable guards mounted on the travelling table".*

*Replace Figure 6 d) with the following:*

"

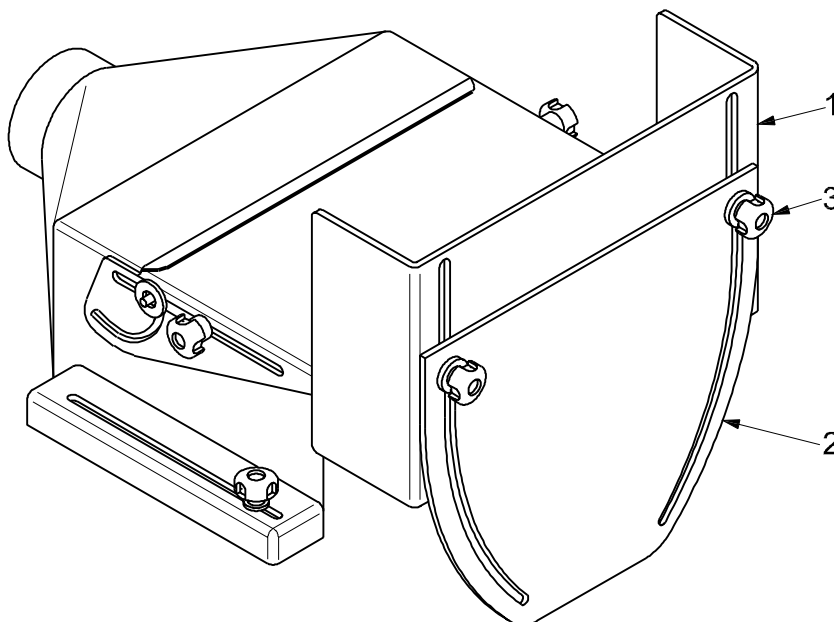

".

*Add the following key:*

- "1 transparent adjustable guard
- 2 transparent self adjusting guard
- 3 device to adjust 16 and to guide 2".

*Replace "Figure 6 d)" with "Figure 7" and renumber the following figures accordingly.*

*In the title of existing Figure 6 d) replace "with transparent self adjusting guard" with "with transparent adjustable guard and transparent self adjusting guard".*

**5 Modifications to Clause 4, List of significant hazards**

*Replace in 1<sup>st</sup> paragraph, in the brackets "EN 1050:1996" with "EN ISO 12100:2010".*