



Designation: D 6244 – 98 (Reapproved 2004)

## Standard Test Method for Vertical Compression of Geocomposite Pavement Panel Drains<sup>1</sup>

This standard is issued under the fixed designation D 6244; the number immediately following the designation indicates the year of original adoption or, in the case of revision, the year of last revision. A number in parentheses indicates the year of last reapproval. A superscript epsilon ( $\epsilon$ ) indicates an editorial change since the last revision or reapproval.

### 1. Scope

1.1 This test method covers vertical strain and core area change of geocomposite pavement panel drains under vertical loading.

1.2 The values as stated in SI units are to be regarded as the standard. The values given in parentheses are for information only.

1.3 *This standard does not purport to address all of the safety concerns, if any, associated with its use. It is the responsibility of the user of this standard to establish appropriate safety and health practices and determine the applicability of regulatory limitations prior to use.*

### 2. Referenced Documents

2.1 *ASTM Standards:*<sup>2</sup>

D 1566 Terminology Relating to Rubber

D 4354 Practice for Sampling of Geosynthetics for Testing

D 4439 Terminology for Geosynthetics

### 3. Terminology

3.1 *Definitions of Terms Specific to This Standard:*

3.1.1 *compressive deformation, n*—the decrease in gage length produced in the test specimen by a compressive load, expressed in units of length (new).

3.1.2 *compressive strain, n*—the ratio of compressive deformation to the gage length of the test specimen, expressed as a dimensionless ratio (new).

3.1.3 *gage length, n*—the known distance between two bench marks (see Terminology D 1566).

<sup>1</sup> This test method is under the jurisdiction of ASTM Committee D35 on Geosynthetics and is the direct responsibility of Subcommittee D35.01 on Mechanical Properties.

Current edition approved June 1, 2004. Published July 2004. Originally approved in 1998. Last previous edition approved in 1998 as D 6244 - 98.

<sup>2</sup> For referenced ASTM standards, visit the ASTM website, www.astm.org, or contact ASTM Customer Service at service@astm.org. For *Annual Book of ASTM Standards* volume information, refer to the standard's Document Summary page on the ASTM website.

3.1.3.1 *Discussion*—In compression testing of geosynthetics, gage length is the measured thickness of the test specimen under specified compressional force, expressed in units of length.

3.1.4 *geosynthetic, n*—a planar product manufactured from polymeric material used with foundation, soil, rock, earth, or any other geotechnical engineering-related materials as an integral part of a manmade project, structure, or system (see Terminology D 4439).

3.1.5 *index test, n*—a test procedure, which may contain a known bias but which may be used to order a set of specimens with respect to the property of interest (see Terminology D 4439).

### 4. Summary of Test Method

4.1 Geocomposite pavement panel drains are placed into a 304.8-mm (12-in.) long, 106.7-mm (4.20-in.) wide, and 610-mm (24-in.) tall glass and aluminum compression chamber. The panels are placed against the wall of the chamber. The remainder of the chamber is then backfilled with a specified sand. A vertical load is applied at a constant rate. The vertical strains of the panels and change in core area and height is recorded at 1112.5-N (250-lb) increments. The test is discontinued at 4450 N (1 000 lb) or 156.5 kPa (22.7 psi). The change in vertical strain, core height, and core area is determined.

### 5. Significance and Use

5.1 The vertical compression test for geocomposite pavement panel drains is intended to simulate vertical, horizontal, and eccentric loading resulting from an applied vertical load. The results of the analyses, including vertical strain of the panels and core area change, may be used as an index test. The vertical compression test may be used to evaluate core area change for a given load.

5.2 The vertical compression test may be used to evaluate percent vertical strain for a given load.

5.3 This test method may be modified to evaluate core area change and vertical strain under various backfill conditions.

6. Apparatus

6.1 *Compression Machine*—A compression machine that is capable of producing at least 4450 N (1 000 lb) of load. The machine must be capable of loading at a rate of 445 N (100 lbs)/min, and maintaining a constant load for an indefinite period.

6.2 *Compression Box*—The box must be capable of holding the specimen and the backfill material, and it must be capable of supporting a minimum vertical load of 4450 N (1 000 lb). The design of the box and the loading plate shall conform to the attached Fig. 1. The box shall be rigid enough to resist deformation.

6.3 *Clear Plastic Spacers (shown and described in Fig. 2)*—These spacers are used to protect the tempered glass ends of the compression box from scratches.

6.4 *Sand*—Sufficient sand to fill the compression box. Natural sand is recommended. The sand shall have a gradation conforming to Table 1. The sand shall be oven dried and cooled to room temperature.

6.5 *Tracing Paper*—The paper must be suitable for tracing and have a minimum size of 220 mm by 508 mm (8.5 in. by 20 in.).

6.6 *Light Source*—Any high intensity point light source is acceptable (for example, a large mag light).

6.7 *Planimeter*—The planimeter is used to determine area to calculate loss of core area at the various load increments (a minimum of a digital planimeter should be used to calculate core area). If computer digitizing equipment or scanning equipment is available, this may be used in lieu of the planimeter.

6.8 *Scale (Length Measuring Device)*—A minimum range of 450 mm (18 in.), and an accuracy of 1 mm (1/16 in.).

7. Sampling

7.1 *Lot Sample*—Divide the product into lots and take the lot sample as directed in Practice D 4354.

7.2 *Laboratory Sample*—Consider the units in the lot sample as the units in the laboratory sample for the lot to be tested. Take for a laboratory sample a sample extending the full width of the panel drain, of sufficient length so that the requirements in 7.3 are met.

NOTE 1—This test method only addresses products with uniform (parallel and perpendicular) geometry. This procedure does not address products with other geometry.

7.3 The height of the drain sample tested shall be equal to the height of the drain in the field unless otherwise agreed to by the purchaser and manufacturer. The length of the drain sample shall be 298.5 mm (11.75 in.). The sample length shall be cut

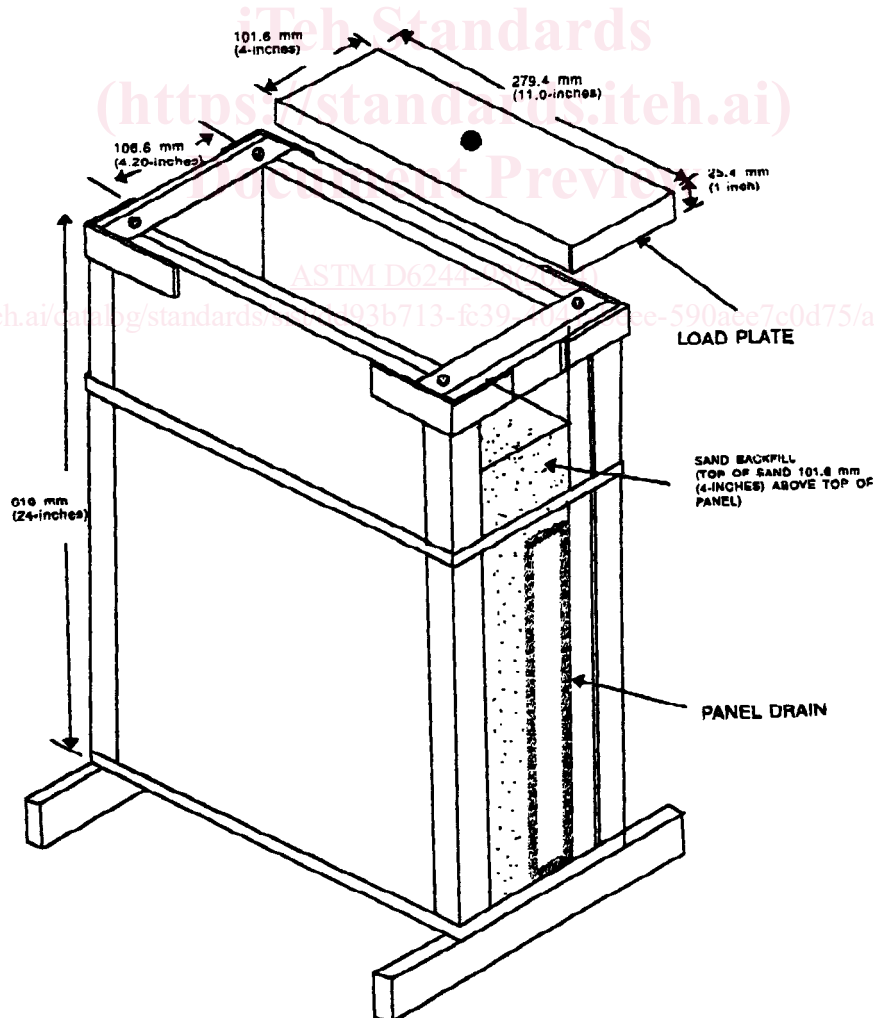

FIG. 1 Edge Drain Compression Chamber