



SLOVENSKI STANDARD
SIST EN 14601:2005+A1:2011
01-april-2011

Železniške naprave - Ravne in kotne zaporne pipe za zavorne in glavne zračne vode

Railway applications - Straight and angled end cocks for brake pipe and main reservoir pipe

Bahnanwendungen - Gerade und abgewinkelte Luftabsperrhähne für die Hauptluftleitung und Hauptbehälterleitung

Applications ferroviaires - Robinets d'arrêt droit ou coudé pour conduite générale de frein et conduite principale

ITeH STANDARD PREVIEW
(standards.iteh.ai)

[SIST EN 14601:2005+A1:2011](https://standards.iteh.ai/catalog/standards/sist/91d886dd-7dd2-481a-831a-27ef7e28369d/sist-en-14601-2005a1-2011)

[https://standards.iteh.ai/catalog/standards/sist/91d886dd-7dd2-481a-831a-](https://standards.iteh.ai/catalog/standards/sist/91d886dd-7dd2-481a-831a-27ef7e28369d/sist-en-14601-2005a1-2011)

[27ef7e28369d/sist-en-14601-2005a1-2011](https://standards.iteh.ai/catalog/standards/sist/91d886dd-7dd2-481a-831a-27ef7e28369d/sist-en-14601-2005a1-2011)

Ta slovenski standard je istoveten z: EN 14601:2005+A1:2010

ICS:

45.040 Materiali in deli za železniško Materials and components
tehniko for railway engineering

SIST EN 14601:2005+A1:2011

en,fr,de

iTeh STANDARD PREVIEW
(standards.iteh.ai)

SIST EN 14601:2005+A1:2011

<https://standards.iteh.ai/catalog/standards/sist/91d886dd-7dd2-481a-831a-27ef7e28369d/sist-en-14601-2005a1-2011>

EUROPEAN STANDARD
NORME EUROPÉENNE
EUROPÄISCHE NORM

EN 14601:2005+A1

October 2010

ICS 45.060.01

Supersedes EN 14601:2005

English Version

Railway applications - Straight and angled end cocks for brake pipe and main reservoir pipe

Applications ferroviaires - Robinets d'arrêt droit ou coudé
pour conduite générale de frein et conduite principale

Bahnanwendungen - Gerade und abgewinkelte
Luftabsperrhähne für die Hauptluftleitung und
Hauptbehälterleitung

This European Standard was approved by CEN on 24 March 2005 and includes Amendment 1 approved by CEN on 30 August 2010.

CEN members are bound to comply with the CEN/CENELEC Internal Regulations which stipulate the conditions for giving this European Standard the status of a national standard without any alteration. Up-to-date lists and bibliographical references concerning such national standards may be obtained on application to the CEN Management Centre or to any CEN member.

This European Standard exists in three official versions (English, French, German). A version in any other language made by translation under the responsibility of a CEN member into its own language and notified to the CEN Management Centre has the same status as the official versions.

CEN members are the national standards bodies of Austria, Belgium, Bulgaria, Croatia, Cyprus, Czech Republic, Denmark, Estonia, Finland, France, Germany, Greece, Hungary, Iceland, Ireland, Italy, Latvia, Lithuania, Luxembourg, Malta, Netherlands, Norway, Poland, Portugal, Romania, Slovakia, Slovenia, Spain, Sweden, Switzerland and United Kingdom.

[SIST EN 14601:2005+A1:2011](https://standards.iteh.ai/catalog/standards/sist/91d886dd-7dd2-481a-831a-27ef7e28369d/sist-en-14601-2005a1-2011)

<https://standards.iteh.ai/catalog/standards/sist/91d886dd-7dd2-481a-831a-27ef7e28369d/sist-en-14601-2005a1-2011>



EUROPEAN COMMITTEE FOR STANDARDIZATION
COMITÉ EUROPÉEN DE NORMALISATION
EUROPÄISCHES KOMITEE FÜR NORMUNG

Management Centre: Avenue Marnix 17, B-1000 Brussels

Contents

Page

Foreword.....	4
1 Scope.....	5
2 Normative references	5
3 Terms and definitions.....	5
4 Requirements	9
4.1 General.....	9
4.2 Operating conditions	9
4.3 Functional characteristics.....	9
4.3.1 General.....	9
4.3.2 Open and closed positions	10
4.3.3 Lubrication.....	10
4.3.4 Venting port.....	10
4.3.5 Torque.....	10
4.3.6 Spindle handle of the end cock	10
4.3.7 Fall time.....	11
4.3.8 Leakage.....	11
4.3.9 Vacuum withstanding.....	11
4.3.10 Pneumatic shocks.....	11
4.4 Constructional characteristics.....	11
4.4.1 External appearance	11
4.4.2 Connections	11
4.4.3 Space envelope	11
4.4.4 Mechanical shocks	11
4.4.5 Resistance to torque.....	12
4.4.6 Life expectancy	12
5 Type test methods	12
5.1 Sampling for type test	12
5.2 Test requirements	12
5.3 Test procedure	12
5.3.1 Principle	12
5.3.2 Check of physical and geometrical characteristics	13
5.3.3 Measurement of the operating torque	14
5.3.4 Measurement of the pressure fall time	14
5.3.5 Hydraulic test (water pressure) of the end cock body at given pressure.....	16
5.3.6 Operating test under air flow condition.....	16
5.3.7 Pneumatic test of the isolating device at given pressures and temperatures	17
5.3.8 Endurance at ambient temperature with reduced air flow.....	18
5.3.9 Measurement of the operating torque drift	19
5.3.10 Vibration test	20
5.3.11 Resistance to shock test.....	20
5.3.12 Vacuum test.....	20
5.3.13 Corrosion test.....	21
5.3.14 Resistance to torque:	22
5.3.15 Examination	23
5.4 Approval validity	23
5.5 Type test report.....	23
6 Homologation	23
6.1 General.....	23
6.1.1 Procedure	23

6.1.2	Pass/fail criteria.....	24
6.2	Homologation test report	24
7	Routine tests	24
8	Designation.....	24
9	Marking	24
Annex A (normative) Dimensions of end cocks.....		26
Annex ZA (informative) A1 Relationship between this European Standard and the Essential Requirements of EU Directive 2008/57/EC of the European Parliament and of the Council of 17 June 2008 on the interoperability of the rail system within the Community (Recast) A1		30
A1 deleted text A1		36
Bibliography		36

iTeh STANDARD PREVIEW (standards.iteh.ai)

[SIST EN 14601:2005+A1:2011](https://standards.iteh.ai/catalog/standards/sist/91d886dd-7dd2-481a-831a-27ef7e28369d/sist-en-14601-2005a1-2011)

<https://standards.iteh.ai/catalog/standards/sist/91d886dd-7dd2-481a-831a-27ef7e28369d/sist-en-14601-2005a1-2011>

EN 14601:2005+A1:2010 (E)**Foreword**

This document (EN 14601:2005+A1:2010) has been prepared by Technical Committee CEN/TC 256 "Railway applications", the secretariat of which is held by DIN.

This European Standard shall be given the status of a national standard, either by publication of an identical text or by endorsement, at the latest by April 2011, and conflicting national standards shall be withdrawn at the latest by April 2011.

Attention is drawn to the possibility that some of the elements of this document may be the subject of patent rights. CEN [and/or CENELEC] shall not be held responsible for identifying any or all such patent rights.

This document includes Amendment 1, approved by CEN on 2010-08-30.

This document supersedes EN 14601:2005.

The start and finish of text introduced or altered by amendment is indicated in the text by tags \square_{A1} \square_{A1} .

\square_{A1} This document has been prepared under a mandate given to CEN/CENELEC/ETSI by the European Commission and the European Free Trade Association, and supports essential requirements of EU Directive 2008/57/EC.

For relationship with EU Directive 2008/57/EC, see informative Annex ZA, which is an integral part of this document. \square_{A1}

[SIST EN 14601:2005+A1:2011](https://standards.iteh.ai/catalog/standards/sist/91d886dd-7dd2-481a-831a-27e7e28369d/sist-en-14601-2005a1-2011)

According to the CEN/CENELEC Internal Regulations, the national standards organizations of the following countries are bound to implement this European Standard: Austria, Belgium, Bulgaria, Croatia, Cyprus, Czech Republic, Denmark, Estonia, Finland, France, Germany, Greece, Hungary, Iceland, Ireland, Italy, Latvia, Lithuania, Luxembourg, Malta, Netherlands, Norway, Poland, Portugal, Romania, Slovakia, Slovenia, Spain, Sweden, Switzerland and United Kingdom.

1 Scope

This European Standard is applicable to manually operated end cocks designed to cut-off the brake pipe and the main reservoir pipe of the air brake and compressed air system of rail vehicles; without taking the type of vehicles and track-gauge into consideration.

This European Standard specifies requirements for the design, dimensions, testing and certification (qualification and/or homologation), and marking.

2 Normative references

The following referenced documents are indispensable for the application of this document. For dated references, only the edition cited applies. For undated references, the latest edition of the referenced document (including any amendments) applies.

EN 50125-1, *Railway applications — Environmental conditions for equipment — Part 1: Equipment on board rolling stock*

EN 61373, *Railway applications — Rolling stock equipment — Shock and vibration tests (IEC 61373:1999)*

EN ISO 228-2, *Pipe threads where pressure-tight joints are not made on the threads — Part 2: Verification by means of limit gauges (ISO 228-2:1987)*

ISO 5208:1993, *Industrial valves — Pressure testing of valves*

ISO 8573-1:2001, *Compressed air — Part 1: Contaminants and purity classes*

ISO 9227:1990, *Corrosion tests in artificial atmospheres — Salt spray tests*

3 Terms and definitions

For the purposes of this document, the following terms and definitions shall apply.

3.1

end cock

two position, three way cock, with no piped vent and, with a rotary spindle moved by the operating handle

3.2 Components

3.2.1

port

terminus of a fluid passage in a component (to which may be connected pipelines) for the transmission of fluid to, or from the component

3.2.1.1

venting port

port which provides passage to atmosphere

3.2.1.2

outlet port

port which is vented to atmosphere when the cock is closed

EN 14601:2005+A1:2010 (E)**3.2.1.3****inlet port**

port which is not vented when the cock is closed

3.2.1.4**threaded port**

port arranged to accept screw threaded connection

3.2.2**direction of rotation**

direction of rotation quoted as viewed looking at the handle side

NOTE In case of doubt a sketch should be provided.

3.2.3**mechanical detent**

spring arrangement to retain moving parts in open or closed position and only able to be moved to another position with the specified force

3.2.4**latch**

mechanical device to retain moving parts in open or closed position which can only be moved when the latch is released

3.3 Types of end cocks**3.3.1 Design****3.3.1.1****straight end cock**

cock with axis of inlet and outlet ports in line

NOTE See Figure 1.

iTeh STANDARD PREVIEW
(standards.iteh.ai)

SIST EN 14601:2005+A1:2011
<https://standards.iteh.ai/catalog/standards/sist/91d886dd-7dd2-481a-831a-27ef7e28369d/sist-en-14601-2005a1-2011>

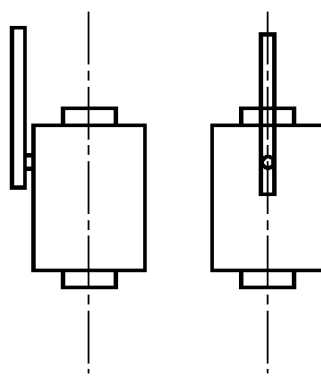

Figure 1 — Straight end cock

3.3.1.2**angled end cock**

cock with axis of outlet port at an angle of $(35 \pm 2)^\circ$ with axis of inlet port

NOTE See Figure 2.

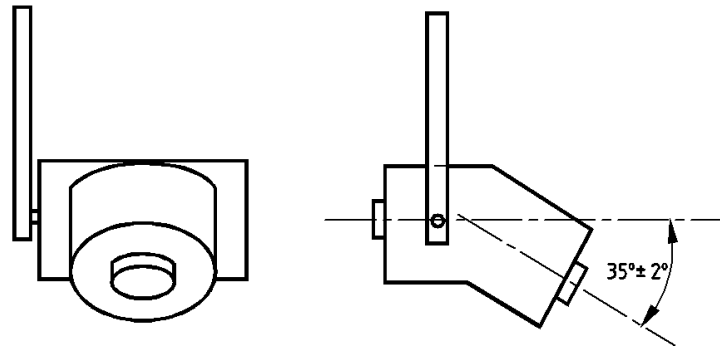

Figure 2 — Angled end cock

3.3.2 Location of the handle

3.3.2.1

right hand end cock

handle located at the right hand side of the end cock with the handle closed in a vertically upwards position

NOTE 1 The end cock is opened by rotating the handle in an anticlockwise direction (see Figure 3).

NOTE 2 Standard mounting position. Other positions of handle are defined by drawing (see Figure 3).

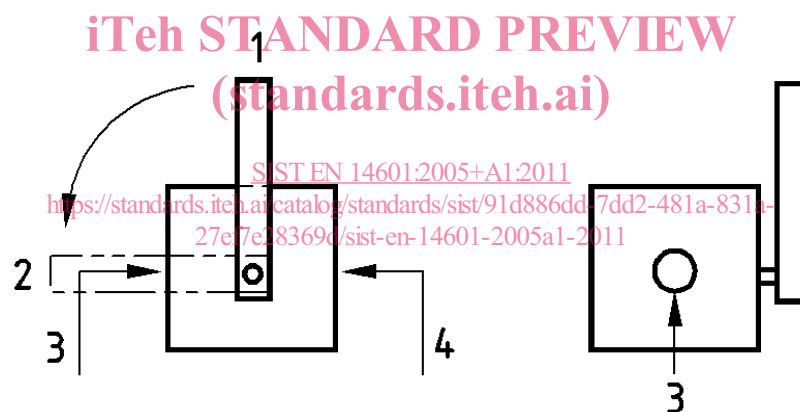

Key

- 1 Closed position
- 2 Open position
- 3 Outlet port
- 4 Inlet port

Figure 3 — Right hand end cock

3.3.2.2

left hand end cock

handle located at the left hand side of the cock with the handle closed is in a vertically upwards position

NOTE 1 The cock is opened by rotating the handle in a clockwise direction (see Figure 4).

NOTE 2 Standard mounting position. Other positions of handle are defined by drawing (see Figure 4).

EN 14601:2005+A1:2010 (E)

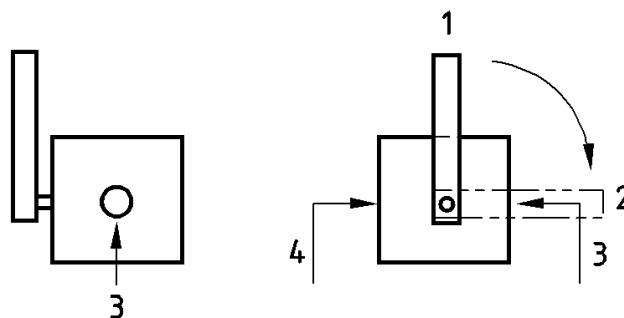
**Key**

- 1 Closed position
- 2 Open position
- 3 Outlet port
- 4 Inlet port

Figure 4 — Left hand end cock**3.4 States****3.4.1****closed position**

position of the valve component part in which the flow path between inlet and outlet ports is closed and the venting passage is open and connected to the hose and coupling side of the cock

NOTE 1 The cock handle is closed in the vertically upwards position on the vehicle.

NOTE 2 The purchaser will define the angle between the cock inlet port axis and the vertically upwards handle position for cocks not mounted horizontally.

3.4.2**open position**

position of the valve member in which the flow path between inlet and outlet ports is fully open, and the venting passage is closed

3.4.3**fall time**

time taken in a device for a quantity of air to fall from a specified high pressure level down to a specified lower pressure level

NOTE Parameter used to define the fluid characteristic of the cock.

3.4.4**proof pressure**

test pressure, in excess of a maximum rated pressure, which causes no malfunction or permanent deformation damage

3.5**temperature range**

range of the temperature within which the apparatus can operate satisfactorily

3.6 Leakage**3.6.1****external leakage**

leakage of the fluid contained in the end cock to atmosphere

3.6.2**internal leakage**

leakage of the fluid contained in the end cock from one side to the other side with the valve component part in the closed position

3.7**drift**

change or variation of a condition with time under steady state operating conditions

3.8**life expectancy**

predicted working period during which a component or system will maintain a specified level of performance under specified conditions

NOTE Sometimes expressed in statistical term as a probability.

4 Requirements**4.1 General**

Workmanship and quality shall be ensured by the manufacturer, therefore quality assurance is the responsibility of the manufacturer under the agreement with the purchaser. Warranty of the part is also the responsibility of the manufacturer in accordance with the agreement with the purchaser.

4.2 Operating conditions

The end cock shall be able to function under the following conditions:

- iTech STANDARD PREVIEW
(standards.itech.ai)
- SIST EN 14601:2005+A1:2011
http://standards.itech.ai/catalog/standards/sist/14601dd7/dd2461a-851a-27e1/c28569/sist-en-14601-2005a1-2011
- a) Where the air quality of the compressed air specified in ISO 8573-1:2001, class 4-4-5. This requirement is verified when tests are carried out in accordance with 5.2.
 - b) In the temperature range for the environmental conditions to which the rail vehicle is submitted during its operation and at least for a temperature range defined by the class T2 of EN 50125-1. The purchaser can specify a higher temperature value if operational constraints demand it. This requirement is tested in accordance with 5.3.3, 5.3.7 and 5.3.12.
 - c) The end cock shall withstand the external corrosion due to normal atmospheric pollutants as specified in EN 50125-1. The end cock is tested in accordance with the test shown in 5.3.13.
 - d) In the vibrational environment of the rail vehicle on which it is mounted and it shall remain in either the open or closed position. The cock shall be tested in accordance with 5.3.10.

4.3 Functional characteristics**4.3.1 General**

The operating handle of the end cock shall be equipped with a detent or latch system.

The requirements given in 4.3.2 to 4.3.10 are defined to ensure the air flow through the brake pipe and main reservoir pipe and ensure no malfunction of the cock after the brake pipe test (as part of the brake test before the trains start).

EN 14601:2005+A1:2010 (E)

4.3.2 Open and closed positions

The handle position shall be the same on any vehicle, so the opening and closing of the cock shall be achieved by turning its spindle through a minimum of 90° and not more than 100°. Stops shall be provided at the extremes of rotation, so that the open and closed positions are achieved positively. The open and closed positions are defined in 3.4.1 and 3.4.2.

4.3.3 Lubrication

It shall be possible to operate the end cock at all pressures without additional lubrication.

4.3.4 Venting port

The end cock shall incorporate a venting port with a minimum area of 80 mm², arranged so that when the cock is closed the compressed air from the coupling hose end of the cock (outlet port connected to the next vehicle) can be exhausted to atmosphere. Venting shall have commenced when the operation of the end cock has reduced the cross-sectional area of the bore of the end cock by one third. The venting port shall not be able to be obstructed when the cock is mounted on the rail vehicle.

The venting port shall be designed and arranged such that the under usual operation, the operating personnel are not endangered by the exhaust-flow, or objects carried by it, nor by excessive noise level.

4.3.5 Torque

All end cocks with mechanical detent, or with latch engaged shall not be operated by vibration or shocks. The end cock shall be capable of manual operation therefore the operating torque of the handle shall be in the range of 9 Nm to 20 Nm for end cocks with detent and a maximum of 6 Nm for cocks with latch. The torque is tested in accordance with 5.3.3. Torque drifts shall not be allowed. This requirement is tested in accordance with 5.3.9.

4.3.6 Spindle handle of the end cock

Where the handle is detachable and the unique angular relationship between it and the spindle is not constructionally assured, it shall not be possible to assemble the handle to the spindle except where the axis of the handle and the diametrical spindle mark are aligned and the spindle shall be marked in accordance with Figure 5 or as otherwise specified by the purchaser. The relative position of the handle and spindle, when assembled, shall be maintained under all operating and environmental conditions. The notch in accordance with Figure 5 indicates the position of the spindle (open/closed).

NOTE Detachable handles and the spindle should be designed in such a way that an unambiguous angular relationship between handle and spindle will remain.

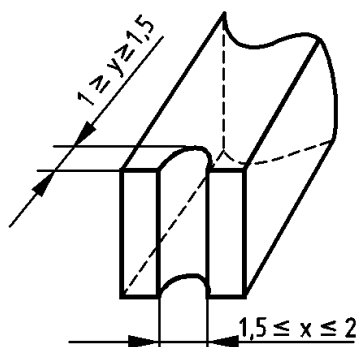

Figure 5 — Marking on end of the spindle