

---

---

**Fruit and vegetable products —  
Determination of mineral impurities  
content**

*Produits dérivés des fruits et légumes — Détermination de la teneur en  
impuretés minérales d'origine terrestre*

**iTeh STANDARD PREVIEW**  
**(standards.iteh.ai)**

ISO 762:2003

<https://standards.iteh.ai/catalog/standards/sist/112ca43c-6cac-4556-ae66-809e71071fb3/iso-762-2003>



**PDF disclaimer**

This PDF file may contain embedded typefaces. In accordance with Adobe's licensing policy, this file may be printed or viewed but shall not be edited unless the typefaces which are embedded are licensed to and installed on the computer performing the editing. In downloading this file, parties accept therein the responsibility of not infringing Adobe's licensing policy. The ISO Central Secretariat accepts no liability in this area.

Adobe is a trademark of Adobe Systems Incorporated.

Details of the software products used to create this PDF file can be found in the General Info relative to the file; the PDF-creation parameters were optimized for printing. Every care has been taken to ensure that the file is suitable for use by ISO member bodies. In the unlikely event that a problem relating to it is found, please inform the Central Secretariat at the address given below.

**iTeh STANDARD PREVIEW**  
**(standards.iteh.ai)**

ISO 762:2003

<https://standards.iteh.ai/catalog/standards/sist/112ca43c-6cac-4556-ae66-809e71071fb3/iso-762-2003>

© ISO 2003

All rights reserved. Unless otherwise specified, no part of this publication may be reproduced or utilized in any form or by any means, electronic or mechanical, including photocopying and microfilm, without permission in writing from either ISO at the address below or ISO's member body in the country of the requester.

ISO copyright office  
Case postale 56 • CH-1211 Geneva 20  
Tel. + 41 22 749 01 11  
Fax + 41 22 749 09 47  
E-mail [copyright@iso.org](mailto:copyright@iso.org)  
Web [www.iso.org](http://www.iso.org)

Published in Switzerland

## Foreword

ISO (the International Organization for Standardization) is a worldwide federation of national standards bodies (ISO member bodies). The work of preparing International Standards is normally carried out through ISO technical committees. Each member body interested in a subject for which a technical committee has been established has the right to be represented on that committee. International organizations, governmental and non-governmental, in liaison with ISO, also take part in the work. ISO collaborates closely with the International Electrotechnical Commission (IEC) on all matters of electrotechnical standardization.

International Standards are drafted in accordance with the rules given in the ISO/IEC Directives, Part 2.

The main task of technical committees is to prepare International Standards. Draft International Standards adopted by the technical committees are circulated to the member bodies for voting. Publication as an International Standard requires approval by at least 75 % of the member bodies casting a vote.

Attention is drawn to the possibility that some of the elements of this document may be the subject of patent rights. ISO shall not be held responsible for identifying any or all such patent rights.

ISO 762 was prepared by Technical Committee ISO/TC 34, *Food products*, Subcommittee SC 3, *Fruit and vegetable products*.

This second edition cancels and replaces the first edition (ISO 762:1982), which has been technically revised.

**iTeh STANDARD PREVIEW**  
**(standards.iteh.ai)**

ISO 762:2003

<https://standards.iteh.ai/catalog/standards/sist/112ca43c-6cac-4556-ae66-809e71071fb3/iso-762-2003>

**iTeh STANDARD PREVIEW**  
**(standards.iteh.ai)**

ISO 762:2003

<https://standards.iteh.ai/catalog/standards/sist/112ca43c-6cac-4556-ae66-809e71071fb3/iso-762-2003>

# Fruit and vegetable products — Determination of mineral impurities content

## 1 Scope

This international Standard specifies a method for the determination of the mineral impurities content (impurities generally originating from the soil) of fruit and vegetable products.

## 2 Principle

Organic matter is separated by flotation and heavy impurities are separated by sedimentation. The sediment is incinerated at approximately 525 °C, and the residue obtained is weighed.

## 3 Apparatus

Usual laboratory equipment and, in particular, the following.

**3.1 Blender.**

**3.2 Beakers**, of capacities 1 000 ml.

**3.3 Filter paper**, Whatman No. 41<sup>1)</sup> or equivalent.

**3.4 Incineration dishes**, made of quartz, porcelain or platinum.

**3.5 Muffle furnace**, capable of being maintained at 525 °C ± 25 °C.

**3.6 Desiccator**, provided with an efficient desiccant.

**3.7 Analytical balance**, capable of weighing to the nearest 0,000 2 g.

**3.8 Heater**, gas or electric.

**3.9 Sieve**, of pore size ca. 1 mm to 2 mm.

**3.10 Stirring rod.**

**3.11 Washing equipment**, for washing out the impurities (see Figure 1).

1) Whatman No. 41 is an example of a suitable product available commercially. This information is given for the convenience of users of this International Standard and does not constitute an endorsement by ISO of this product.

## 4 Preparation of test sample

### 4.1 General case

Before taking the test portion, thoroughly mix the entire laboratory sample using, if necessary, the blender (3.1). Allow frozen or deep frozen products to thaw in a closed vessel and add the liquid formed during this process to the product before mixing.

### 4.2 Dried products

Mix the laboratory sample well. Weigh  $20 \text{ g} \pm 0,1 \text{ g}$  of the product, transfer it to a beaker (3.2) and add 400 ml of filtered tap water. Bring to the boil, then leave overnight at room temperature to allow the product to rehydrate.

## 5 Procedure

### 5.1 Test portion

#### 5.1.1 General case

Rapidly weigh  $100 \text{ g} \pm 1 \text{ g}$  of the test sample (4.1) into a beaker (3.2). If the mass of this sample is less than 100 g, weigh all of it.

**iTeh STANDARD PREVIEW**  
**(standards.iteh.ai)**

#### 5.1.2 Dried products

Use all of the product taken in 4.2 as the test portion.

[ISO 762:2003](https://standards.iteh.ai/catalog/standards/sist/112ca43c-6cac-4556-ae66-809e71071fb3/iso-762-2003)

### 5.2 Determination

<https://standards.iteh.ai/catalog/standards/sist/112ca43c-6cac-4556-ae66-809e71071fb3/iso-762-2003>

#### 5.2.1 Separation of sediments

Add filtered tap water to the beaker containing the test portion (4.1 or 4.2) until the beaker is almost completely full. Mix by agitating, if necessary using a stirring rod (3.10).

Allow the suspension to stand for 5 min, then put the beaker under the water tube as shown in Figure 1.

The important part of the washing equipment (3.11) is the water tank equipped with a leak tube for equalizing the pressure. In the tank, the water level shall be constant and 13 cm high; the overflow leaves the tank through the leak tube. One or more glass tubes, with 0,4 cm internal diameter, are connected to the bottom of the tank by rubber tubes. Their end parts are extruded. The distance between the bottom of the tank and the top end of the glass tube shall be 55 cm, the extruded part shall be 1 cm long and its internal diameter shall be 0,2 cm. The opening and closing of the stream is controlled by a clamp. Keeping these conditions, the flow rate through one glass tube shall be 200 ml/min. Put a glass tube filled loosely with cotton- or glass-wool between the tap and the tank to retain floating impurities.

Immerse the glass tube in the beaker containing the suspension in such position that the tip of it is 6 cm from the bottom of the beaker. Open the stream and continue the washing for 35 min to 40 min. During this time the fine fragments of plant fibre are washed out, while the sand, other mineral impurities and the larger fragments of seeds and skins settle, and the water becomes colourless and transparent in the beaker.

Dimensions in centimetres

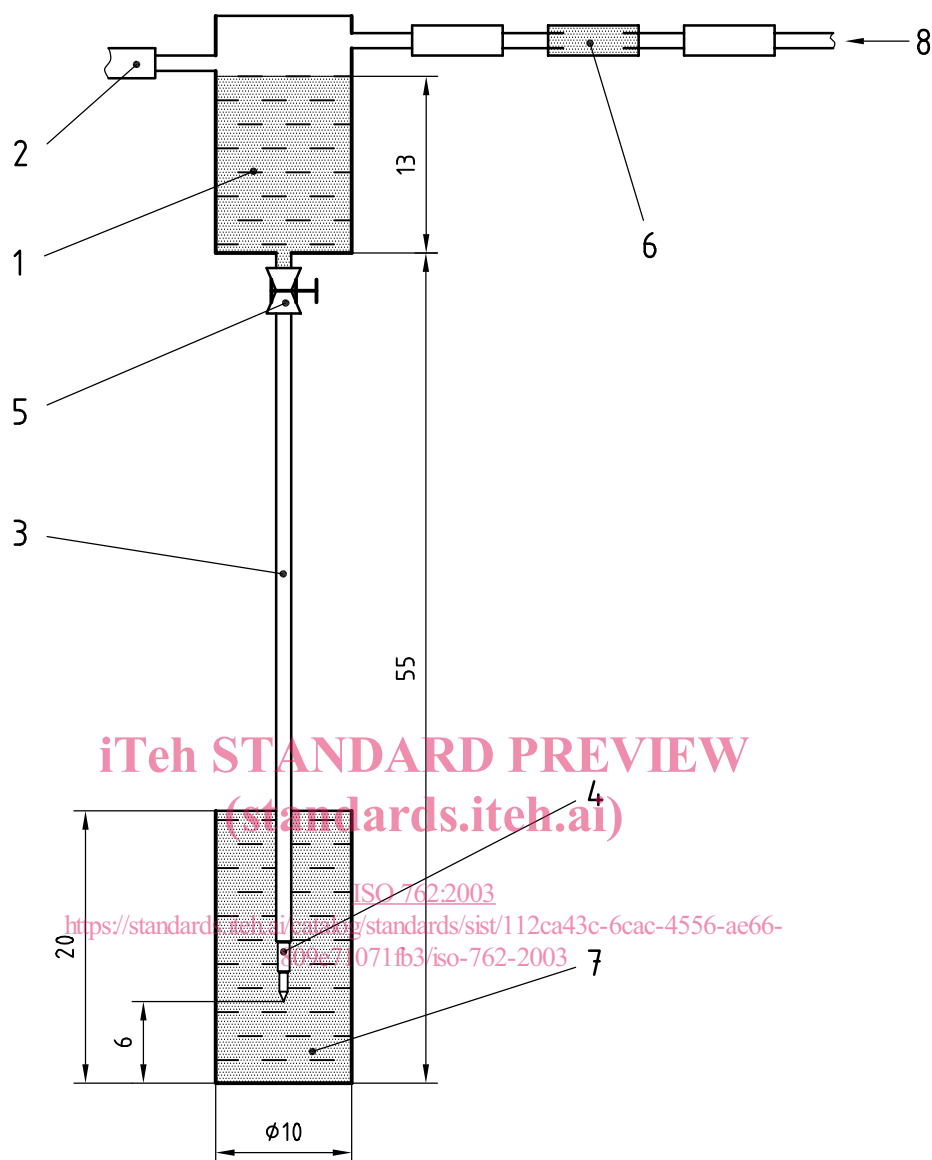

**Key**

- 1 water tank
- 2 leak tube
- 3 glass tube
- 4 end part of glass tube
- 5 clamp
- 6 cotton- or glass-wool
- 7 beaker containing the suspension
- 8 water

**Figure 1 — Washing equipment**

### 5.2.2 Determination

If, after the washing-out procedure (5.2.1), there are no visible fragments of plant but only the sand on the bottom of the beaker, remove the glass tube from the beaker. Wait for 3 min then decant carefully most of the water, avoiding any agitation of the settled fragments. Quantitatively filter the residue through a filter paper (3.3).

If, after the washing-out procedure (5.2.1), there remains a lot of plant fibres and larger fragments of seeds and plant skins on the bottom of the beaker, decant most of the water. Transfer the residue to a sieve (3.9) which is placed on a porcelain dish having an appropriate size. Wash the sand into the dish with water. Pour the water in 100 ml portions to separate the sand from the fragments of skin, seed and fibre. About 1 000 ml water are needed for this purpose.

### 5.2.3 Preparation of the dish

Heat the empty incineration dish (3.4) in the muffle furnace (3.5) set at 525 °C. Allow it to cool in the desiccator (3.6) and weigh to the nearest 0,000 2 g. Repeat until a constant mass is achieved.

### 5.2.4 Incineration

Transfer the filter paper and residue to the prepared incineration dish (5.2.3).

Heat the incineration dish for a few minutes using the heater (3.8), then transfer it to the muffle furnace (3.5) set at 525 °C. Incinerate it for 1 h. Cool in the desiccator (3.6) and weigh to the nearest 0,000 2 g. Repeat until a constant mass is achieved.

### 5.2.5 Number of determinations

(standards.iteh.ai)

Carry out at least two determinations of the same sample.

ISO 762:2003  
<https://standards.iteh.ai/catalog/standards/sist/112ca43c-6cac-4556-ae66-809e71071fb3/iso-762-2003>

## 6 Expression of results

### 6.1 Calculation

The mineral impurities content, expressed as a percentage by mass, is given by the formula

$$(m_2 - m_1) \times \frac{100}{m_0} \%$$

where

$m_0$  is the mass, in grams, of the test portion (5.1);

$m_1$  is the mass, in grams, of the empty dish (5.2.3);

$m_2$  is the mass, in grams, of the dish and incinerated residue (5.2.4).

Take as the result the arithmetic mean of the values obtained in two determinations, provided that the requirement for repeatability (6.2) is satisfied.

Report the result to two decimal places.



## 6.2 Repeatability

The absolute difference between two independent single test results, obtained using the same method on identical test material in the same laboratory by the same operator using the same equipment within a short interval of time, will in not more than 5 % of cases be greater than 3 % of the mean value.

## 7 Test report

The test report shall specify:

- a) all information necessary for the complete identification of the sample;
- b) the sampling method used, if known;
- c) the test method used, with reference to this International Standard;
- d) all operating details not specified in this International Standard, or regarded as optional, together with details of any incidents which may have influenced the test result(s);
- e) the test result(s) obtained or, if the repeatability has been checked, the final quoted result obtained.

**iTeh STANDARD PREVIEW**  
**(standards.iteh.ai)**

ISO 762:2003

<https://standards.iteh.ai/catalog/standards/sist/112ca43c-6cac-4556-ae66-809e71071fb3/iso-762-2003>