Metallic materials — Bend test

Matériaux métalliques — Essai de pliage

iTeh STANDARD PREVIEW
(standards.iteh.ai)

[ISO 7438:2005](https://standards.iteh.ai/catalog/standards/sist/749652e2-0b25-4959-b41c-7eb787e83ce6/iso-7438-2005)

<https://standards.iteh.ai/catalog/standards/sist/749652e2-0b25-4959-b41c-7eb787e83ce6/iso-7438-2005>



PDF disclaimer

This PDF file may contain embedded typefaces. In accordance with Adobe's licensing policy, this file may be printed or viewed but shall not be edited unless the typefaces which are embedded are licensed to and installed on the computer performing the editing. In downloading this file, parties accept therein the responsibility of not infringing Adobe's licensing policy. The ISO Central Secretariat accepts no liability in this area.

Adobe is a trademark of Adobe Systems Incorporated.

Details of the software products used to create this PDF file can be found in the General Info relative to the file; the PDF-creation parameters were optimized for printing. Every care has been taken to ensure that the file is suitable for use by ISO member bodies. In the unlikely event that a problem relating to it is found, please inform the Central Secretariat at the address given below.

iTeh STANDARD PREVIEW
(standards.iteh.ai)

[ISO 7438:2005](#)

<https://standards.iteh.ai/catalog/standards/sist/749652e2-0b25-4959-b41c-7eb787e83ce6/iso-7438-2005>

© ISO 2005

All rights reserved. Unless otherwise specified, no part of this publication may be reproduced or utilized in any form or by any means, electronic or mechanical, including photocopying and microfilm, without permission in writing from either ISO at the address below or ISO's member body in the country of the requester.

ISO copyright office
Case postale 56 • CH-1211 Geneva 20
Tel. + 41 22 749 01 11
Fax + 41 22 749 09 47
E-mail copyright@iso.org
Web www.iso.org

Published in Switzerland

Contents

Page

Foreword	iv
1 Scope	1
2 Symbols and designations	1
3 Principle	1
4 Test equipment	2
5 Test piece	4
6 Procedure	5
7 Interpretation of results	7
8 Test report	7
Annex A (informative) Determination of the bend angle from the measurement of the displacement of the former	8

iTeh STANDARD PREVIEW
(standards.iteh.ai)

[ISO 7438:2005](#)

<https://standards.iteh.ai/catalog/standards/sist/749652e2-0b25-4959-b41c-7eb787e83ce6/iso-7438-2005>

Foreword

ISO (the International Organization for Standardization) is a worldwide federation of national standards bodies (ISO member bodies). The work of preparing International Standards is normally carried out through ISO technical committees. Each member body interested in a subject for which a technical committee has been established has the right to be represented on that committee. International organizations, governmental and non-governmental, in liaison with ISO, also take part in the work. ISO collaborates closely with the International Electrotechnical Commission (IEC) on all matters of electrotechnical standardization.

International Standards are drafted in accordance with the rules given in the ISO/IEC Directives, Part 2.

The main task of technical committees is to prepare International Standards. Draft International Standards adopted by the technical committees are circulated to the member bodies for voting. Publication as an International Standard requires approval by at least 75 % of the member bodies casting a vote.

Attention is drawn to the possibility that some of the elements of this document may be the subject of patent rights. ISO shall not be held responsible for identifying any or all such patent rights.

ISO 7438 was prepared by Technical Committee ISO/TC 164, *Mechanical testing of metals*, Subcommittee SC 2, *Ductility testing*.

This second edition cancels and replaces the first edition (ISO 7438:1985), which has been technically revised.

iTeh STANDARD PREVIEW
(standards.iteh.ai)

[ISO 7438:2005](https://standards.iteh.ai/catalog/standards/sist/749652e2-0b25-4959-b41c-7eb787e83ce6/iso-7438-2005)

<https://standards.iteh.ai/catalog/standards/sist/749652e2-0b25-4959-b41c-7eb787e83ce6/iso-7438-2005>

Metallic materials — Bend test

1 Scope

This International Standard specifies a method for determining the ability of metallic materials to undergo plastic deformation in bending.

This International Standard applies to test pieces taken from metallic products, as specified in the relevant product standard. It is not applicable to certain materials or products, for example tubes in full section or welded joints, for which other standards exist.

2 Symbols and designations

Symbols and designations used in the bend test are shown in Figures 1 and 2 and specified in Table 1.

Table 1 — Symbols and designations
(standard.iTeh.ai)

Symbol	Designation	Unit
a	Thickness or diameter of test piece (or diameter of the inscribed circle for pieces of polygonal cross-section)	mm
b	Width of the test piece	mm
L	Length of the test piece	mm
l	Distance between supports	mm
D	Diameter of the former	mm
α	Angle of bend	degrees
r	Internal radius of bend portion of test piece after bending	mm
f	Displacement of the former	mm
c	Distance between the plane including the horizontal axis of supports and the central axis of the rounded portion of the former before test	mm
p	Distance between the vertical planes including the central axis and the vertical axis of each support and the vertical plane including the horizontal central axis of the former after test	mm

3 Principle

The bend test consists of submitting a test piece of round, square, rectangular or polygonal cross-section to plastic deformation by bending, without changing the direction of loading, until a specified angle of bend is reached.

The axes of two legs of the test piece remain in a plane perpendicular to the axis of bending. In the case of a 180° bend, the two lateral surfaces may, depending on the requirements of the product standard, lie flat against each other or may be parallel at a specified distance, an insert being used to control this distance.

4 Test equipment

4.1 General

The bend test shall be carried out in testing machines or presses equipped with the following devices:

- a) bending device with two supports and a former as shown in Figure 1;
- b) bending device with a V-block and a former as shown in Figure 2;
- c) bending device with a clamp as shown in Figure 3.

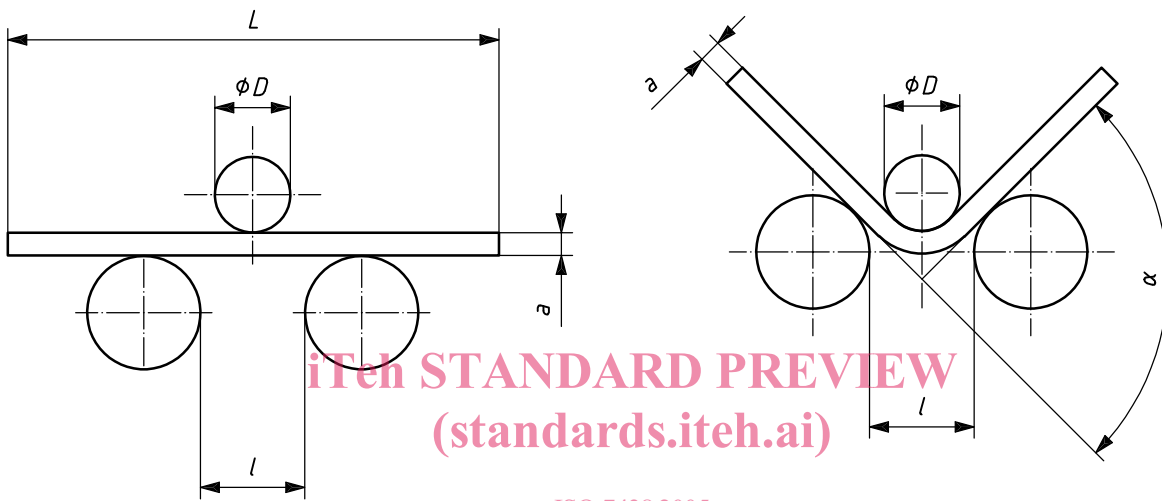

ISO 7438:2005
<https://standards.iteh.ai/catalog/standards/sist/749652e2-0b25-4959-b41c-7eb787777777/iso-7438-2005>
Figure 1

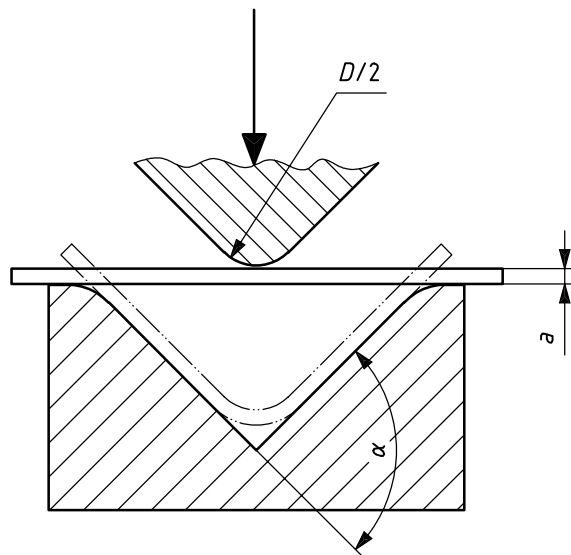
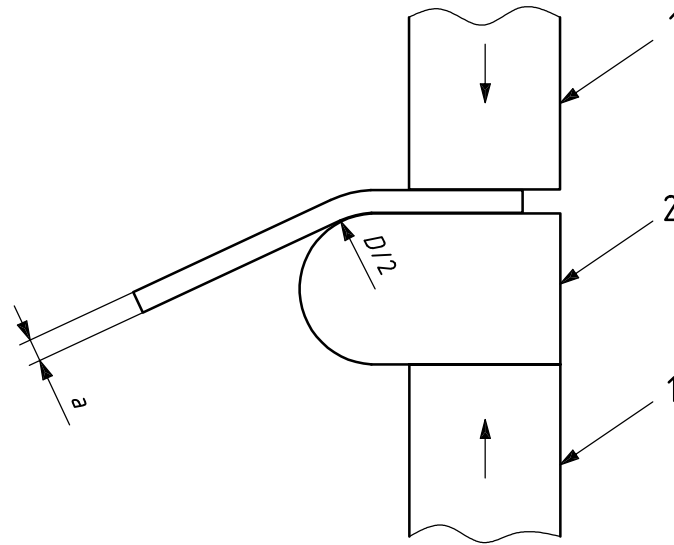

Figure 2

**Key**

- 1 clamp
- 2 former

Figure 3**4.2 Bending device with supports and a former**

4.2.1 The length of the supports and the width of the former shall be greater than the width or diameter of the test piece. The diameter of the former is determined by the product standard. The test piece supports and the former shall be of sufficient hardness (see Figure 1).

4.2.2 Unless otherwise specified, the distance between the supports, l , shall be:

$$l = (D + 3a) \pm \frac{a}{2} \quad (1)$$

and shall not change during the bend test.

4.3 Bending device with a V-block

The tapered surfaces of the V-block shall form an angle of $180^\circ - \alpha$ (see Figure 2). The angle α is specified in the relevant standard.

The edges of the V-block shall have a radius between 1 to 10 times the thickness of the test piece and shall be of sufficient hardness.

4.4 Bending device with a clamp

The device consists of a clamp and a former of sufficient hardness; it may be equipped with a lever for applying force to the test piece (see Figure 3).

Because the position of the left face of the clamp could influence the test results, the left face of the clamp (as shown in Figure 3) should not reach up to or beyond the vertical line through the centre of the circular former shape.

5 Test piece

5.1 General

Round, square, rectangular, or polygonal cross-section test pieces shall be used in the test. Any areas of the material affected by shearing or flame cutting and similar operations during sampling of test pieces shall be removed. However, testing a test piece, the affected parts of which have not been removed, is acceptable, provided the result is satisfactory.

5.2 Edges of rectangular test pieces

The edges of rectangular test pieces shall be rounded to a radius not exceeding the following values:

- 3 mm, when the thickness of the test pieces is 50 mm or greater;
- 1,5 mm, when the thickness of the test pieces is less than 50 mm and more than or equal to 10 mm (inclusive);
- 1 mm when the thickness is less than 10 mm.

The rounding shall be made so that no transverse burrs, scratches or marks are formed which might adversely affect the test results. However, testing a test piece, the edges of which have not been rounded, is acceptable, provided that the result is satisfactory.

5.3 Width of the test piece

Unless otherwise specified in the relevant standard, the width of the test piece shall be as follows:

- a) the same as the product width, if the latter is equal to or less than 20 mm;
- b) when the width of a product is more than 20 mm:
 - (20 ± 5) mm for products of thickness less than 3 mm,
 - between 20 mm and 50 mm for products of thickness equal to or greater than 3 mm.

5.4 Thickness of the test piece

5.4.1 The thickness of test pieces from sheets, strips and sections shall be equal to the thickness of the product to be tested. If the thickness of the product is greater than 25 mm, it may be reduced by machining one surface to attain a thickness not less than 25 mm. During bending, the unmachined side shall be on the tension-side surface of the test piece.

5.4.2 Test pieces of round or polygonal cross-section shall have a cross-section equal to that of the product, if the diameter (for a round cross-section) or inscribed circle diameter (for a polygonal cross-section) does not exceed 30 mm. When the diameter, or the inscribed circle diameter, of the test piece exceeds 30 mm up to and including 50 mm, it may be reduced to not less than 25 mm. When the diameter, or inscribed circle diameter, exceeds 50 mm it shall be reduced to not less than 25 mm (see Figure 4). During bending, the unmachined side shall be on the tension-side surface of the test piece.

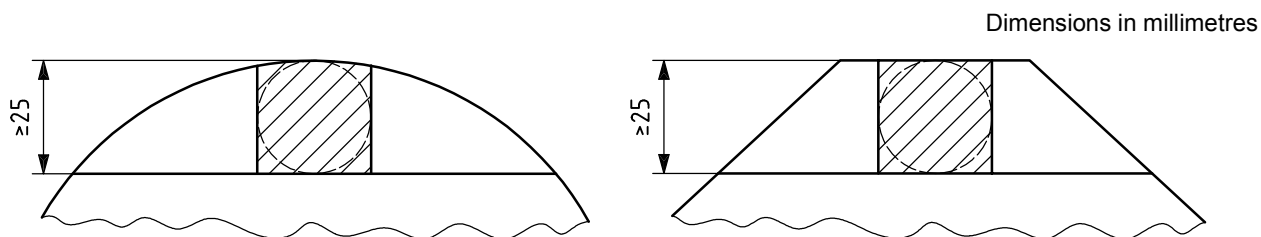

Figure 4

5.5 Test pieces from forgings, castings and semi-finished products

In the case of forgings, castings and semi-finished products, the dimensions of the test piece and sampling shall be as defined in the general delivery requirements, or by agreement.

5.6 Agreement for test pieces of greater thickness and width

By agreement, test pieces of a greater width and thickness than those specified in 5.3 and 5.4 may be subjected to the bend test.

5.7 Length of the test piece

The length of the test piece depends on the thickness of the test piece and the test equipment used.

6 Procedure

WARNING — During the test, adequate safety measures and guarding equipment shall be provided.

6.1 In general, tests are carried out at ambient temperature between 10 °C and 35 °C. Tests carried out under controlled conditions, where required, shall be made at a temperature of (23 ± 5) °C.

6.2 The bend test shall be carried out using one of the following methods as specified in the relevant standard:

- a specified angle of bend is achieved under an appropriate force and for the given conditions (see Figures 1, 2 and 3);
- the legs of the test piece are parallel to each other at a specified distance apart while under an appropriate force (see Figure 6);
- the legs of the test piece are in direct contact while under an appropriate force (see Figure 7).