



Standard Test Method for Filterability of Diesel Fuels by Low-Temperature Flow Test (LTFT)¹

This standard is issued under the fixed designation D 4539; the number immediately following the designation indicates the year of original adoption or, in the case of revision, the year of last revision. A number in parentheses indicates the year of last reapproval. A superscript epsilon (ϵ) indicates an editorial change since the last revision or reapproval.

^{ε1} NOTE—Footnote 9 was corrected editorially in August 2004.

1. Scope*

1.1 This test method covers estimating the filterability of diesel fuels in some automotive equipment at low temperatures.

1.2 The values stated in SI units are to be regarded as the standard. The values in parentheses are for information only.

1.3 *This standard does not purport to address all of the safety concerns, if any, associated with its use. It is the responsibility of the user of this standard to establish appropriate safety and health practices and determine the applicability of regulatory limitations prior to use.* For specific warning statements, see 8.1, 8.2.1, 8.3, 8.5, and Annex A1.

2. Referenced Documents

2.1 ASTM Standards:

- D 97 Test Method for Pour Point of Petroleum Oils²
 - D 975 Specification for Diesel Fuel Oils²
 - D 1655 Specification for Aviation Turbine Fuels²
 - D 2500 Test Method for Cloud Point of Petroleum Products²
 - D 3117 Test Method for Wax Appearance Point of Distillate Fuels²
 - D 3699 Specification for Kerosine³
 - D 4057 Practice for Manual Sampling of Petroleum and Petroleum Products³
 - D 4177 Practice for Automatic Sampling of Petroleum and Petroleum Products³
 - E 1 Specification for ASTM Thermometers⁴
- 2.2 *Coordinating Research Council, Inc.*
- CRC Report No. 528 Diesel Fuel Low-Temperature Operability Field Test⁵

¹ This test method is under the jurisdiction of Committee D02 on Petroleum Products and Lubricants and is the direct responsibility of Subcommittee D02.07 on Flow Properties.

Current edition approved May 10, 2003. Published June 2003. Originally approved in 1985. Last previous edition approved in 2002 as D 4539-02.

² *Annual Book of ASTM Standards*, Vol 05.01.

³ *Annual Book of ASTM Standards*, Vol 05.02.

⁴ *Annual Book of ASTM Standards*, Vol 14.03.

⁵ Available from Coordinating Research Council, Inc., 219 Perimeter Center Parkway, Atlanta, GA 30346.

2.3 *Canadian General Standards Board:*

CAN/CGSB-3.0, No. 14.01-M86, Low Temperature Flow Test (LTFT) for Diesel Fuels⁶

NOTE 1—CAN/CGSB-3.0, No. 14.01-M86 is essentially equivalent to Test Method D 4539, but the differences in apparatus and procedures may or may not yield different results.

3. Summary of Test Method

3.1 The temperature of a series of test specimens of fuel is lowered at a prescribed cooling rate. Commencing at a desired test temperature and at each 1°C interval thereafter, a separate specimen from the series is filtered through a 17- μ m screen until a minimum LTFT pass temperature is obtained. The minimum LTFT pass temperature is the lowest temperature, expressed as a multiple of 1°C, at which a test specimen can be filtered in 60 s or less.

3.2 Alternatively, a single specimen may be cooled as described under 3.1 and tested at a specified temperature to determine whether it passes or fails at that temperature.

4. Significance and Use

4.1 The Low Temperature Flow Test results are indicative of the low temperature flow performance of the test fuel in some diesel vehicles (according to CRC Report No. 528). The test method is especially useful for the evaluation of fuels containing flow improver additives.

4.2 The test method can be used to supplement other measurements of diesel fuel low temperature behavior (in accordance with Test Methods D 97, D 2500, and D 3117).

5. Apparatus

5.1 *Glass Specimen Vessels*, (Borosilicate heat-resistant glass or equivalent) several 300-mL, clear, heat resistant, wide-mouthed glass bottles having markings indicating 200 \pm 10 mL and 50–60 mm ID or clear, heat resistant, tall form beakers with no pour spouts and equivalent dimensions.

5.2 *Glass Receiver Vessels*, clear, heat resistant, glass containers graduated through 180 mL in 10 \pm 2 mL increments.

⁶ Available from CGSB Sales Centre, Ottawa, Canada K1A 1G6.

*A Summary of Changes section appears at the end of this standard.

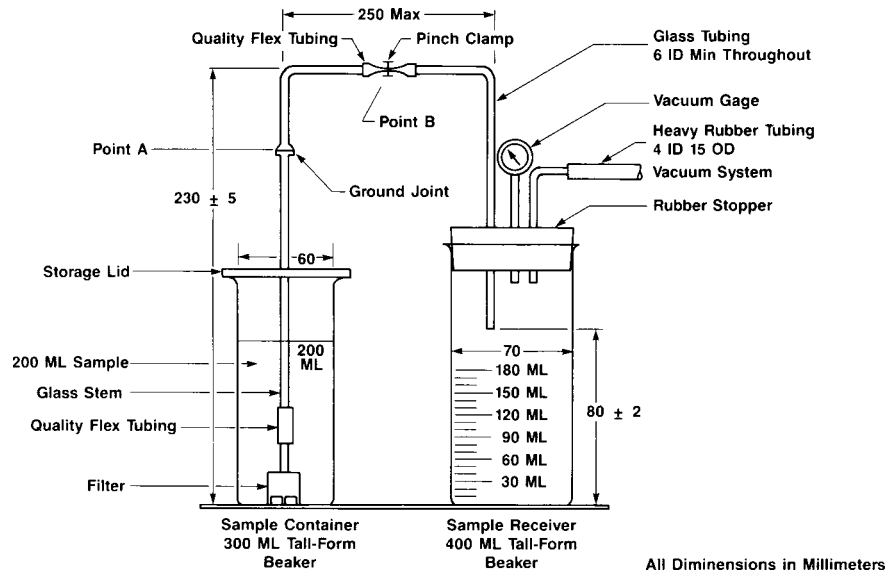

FIG. 1 LTFT Sample Filtration Assembly

5.3 *Filtration Assembly* (see Fig. 1), including a storage lid or some other form of cover, glass tubing, flexible fuel resistant tubing, pinch clamp or valve, and rubber stopper, or other means to provide a vacuum seal.

5.4 *Filter Assembly*⁷, as shown in detail in Fig. 2, for each sample container (300-mL beaker). 304SS sintered screen⁸ is a twill Dutch weave mesh with a nominal filtration rating of 17 μm . The mesh is 65 wires/cm (165 wires/in.) X 303/315 wires/cm (770/800 wires/in.). The wire strands have diameters of 0.0071 cm (0.0028 in.) and 0.0046 cm (0.0018 in.), respectively. The nominal filtration rating indicates a 98 % removal by mass weight of all particles equal to or greater than 17 μm .

5.5 *Programmable Cooling System*, capable of cooling multiple specimens to the desired temperature at a mean rate of 1.0°C per hour between +10°C and -30°C. Absolute deviation of any single temperature point along the prescribed ramp function must not exceed 0.5°C in any specimen. The system's size and shape are optional. Either liquid or air baths are acceptable.

5.6 *Stop Watch or Electric Timer*, capable of measuring tenths of a second.

5.7 *Vacuum System*, capable of maintaining a constant vacuum of 20.0 \pm 0.2 kPa (150 \pm 1.5 mm Hg) below atmospheric pressure at the receiver for the duration of each determination.

⁷ The sole source of supply of the filter assembly known to the committee at this time is Lawler Manufacturing Corp., Kilmer Ct., Edison, NJ and Alberta Research Council, Fuels and Lubricants Group, 250 Karl Clark Rd., Edmonton, Alberta, Canada. If you are aware of alternative suppliers, please provide this information to ASTM International Headquarters. Your comments will receive careful consideration at a meeting of the responsible technical committee¹, which you may attend.

⁸ The sole source of supply of suitable filter cloth known to the committee at this time is Pall Aerospace Co., Pall Aeropower Corp., 6301 49th St. N, Pinellas Park, FL 33781. If you are aware of alternative suppliers, please provide this information to ASTM International Headquarters. Your comments will receive careful consideration at a meeting of the responsible technical committee¹, which you may attend.

5.8 *Temperature Measuring Device (Liquid-in-glass thermometer)*—Conforming to specifications for ASTM Thermometer 114C for air baths or ASTM Thermometer 5C for liquid baths in accordance with Specification E 1, or any other temperature measuring device with equal or better accuracy and equal temperature response.

6. Reagents

6.1 *Jet A Aviation Turbine Fuel*—As specified in Specification D 1655, kerosine, as specified in Specification D 3699, Grade No. 1 (or Grade Low Sulfur No. 1), as specified in Specification D 975, or equivalent liquid that will not separate at temperatures down to -30°C.

6.2 *Heptane*—Reagent grade. (**Warning**—Flammable. See A1.2.)

6.3 *Acetone*—Reagent grade. (**Warning**—Flammable. See A1.1.)

7. Sampling

7.1 Obtain a sample in accordance with Practice D 4057, or by Practice D 4177.

7.2 Each specimen test requires a minimum of 200 mL. Ensure that sufficient sample is obtained to perform the subsequent series of test specimens according to the procedure followed (see Section 3).

8. Procedure

8.1 Filter a fresh specimen of test fuel at 15°C or higher, through dry, lintless filter paper, having a nominal filtration rating of less than 17 μm . (**Warning**—Combustible liquid. See A1.3.)

8.2 Clean and inspect the filter assembly before each test. Filters obtained from the manufacturer are already standardized. Appendix X1 provides a procedure for checking the filter performance, if desired.

8.2.1 Clean the assembled filter with two solvents using a vacuum to draw the solvents through the screen. Begin with